



**LIGHTHOUSE**  
WORLDWIDE SOLUTIONS

# **REMOTE Active Count Biological Air Sampler**

**Controller & Remote Switch System**

Installation Guide



# *Lighthouse Worldwide Solutions*

***REMOTE ActiveCount Biological Air Sampler  
Controller & Remote Switch System***

***Installation Guide***

Copyright © 2012- 2017 by Lighthouse Worldwide Solutions. All rights reserved. No part of this document may be reproduced by any means except as permitted in writing by Lighthouse Worldwide Solutions.

The information contained herein constitutes valuable trade secrets of Lighthouse Worldwide Solutions. You are not permitted to disclose or allow to be disclosed such information except as permitted in writing by Lighthouse Worldwide Solutions.

The information contained herein is subject to change without notice. Lighthouse Worldwide Solutions is not responsible for any damages arising out of your use of the LMS program.

REMOTE ActiveCount™ and LMS™ are trademarks of Lighthouse Worldwide Solutions.

Microsoft®, Microsoft Windows™, and Excel™ are trademarks of Microsoft Corporation.

Manufactured by:

Lighthouse Worldwide Solutions

1221 Disk Drive

Medford, Oregon 97501

LWS Part Number: 248083413-1 Rev 4



## EU DECLARATION OF CONFORMITY

**Manufacturer's Name:** Lighthouse Worldwide Solutions, Inc.

**Manufacturer's Address:** Lighthouse Worldwide Solutions, Inc.  
1221 Disk Drive  
Medford, OR 97501 USA

**Declares that the product:**

**Product Name:** Biological Air Sampler  
**Model Number(s):** REMOTE ActiveCount System

**Conforms to the following Product Specifications:**

<b><u>SAFETY</u></b>	EN61010-1:2001	Safety Requirements for Electrical Equipment for Measurement, Control, and Laboratory Use Part 1: General Requirements IEC 61010-1:2000
	CAN/CSA C22.2 No. 1010.1-1992	Safety Requirements for Electrical Equipment for Measurement, Control and Laboratory Use, Part 1: General Requirements
	IEC 60825-1 Am. 2	

<b><u>EMC</u></b>	EN61326	Electrical Equipment for Measurement, Control and Laboratory Use EMC Requirements Part 1: General Requirements Includes Amendment A1:1998; IEC 61326:1997 + A1:1998
-------------------	---------	---

UL 61010A-1 - UL Standard for Safety Electrical Equipment for Laboratory Use; Part 1: General Requirements  
Replaces UL 3101-1

### **Supplementary information**

The product herewith complies with the requirements of the Low Voltage Directive 73/23/EEC amended by Directive 93/68/EEC and the EMC Directive 89/336/EEC amended by Directive 93/68/EEC and carries the CE marking accordingly.

William Shade - V.P. Engineering

Fremont, CA. November 7, 2011



# Table of Contents

## About this Manual

Text Conventions .....	i
Additional Help .....	i

## Chapter 1 General Safety

Safety Considerations .....	1-1
-----------------------------	-----

## Chapter 2 Introduction

Overview .....	2-1
Interchangeable Terms .....	2-1
Description .....	2-1
REMOTE ActiveCount Specifications .....	2-2

## Chapter 3 Getting Started

Initial Inspection .....	3-1
Unpacking .....	3-1
Shipping Instructions .....	3-2
Installation .....	3-3
DIP Switch Settings .....	3-5
DIP Switch General Definitions .....	3-5
DIP Switch Addressing .....	3-5
RAC Controller RJ-45 Pinouts .....	3-7
Remote Switch RJ-45 Pinouts .....	3-8
Configuring the RAC in LMS Express RT .....	3-9
Remote Switch Operation .....	3-12
Configure Flow Settings .....	3-13

## Chapter 4 Communications

Configuring with the MODBUS Protocol .....	4-1
Configure the RAC System .....	4-1
Operating the RAC System .....	4-2

Access RAC Information ..... 4-2

## Appendix A Limited Warranty

Limitation Of Warranties: ..... A-1  
Warranty Of Repairs After Initial Two (2) Year Warranty: ..... A-1

## Appendix B Remote ActiveCount MODBUS Register Map v1.49

COMM Settings ..... B-1  
Supported MODBUS Commands ..... B-1  
    Sensor Settings Registers ..... B-2  
    Device Status ..... B-6  
Data Registers ..... B-8  
    Data Status Byte (30007 - 30008) ..... B-10  
    Alarm Flags in Channels (30076) ..... B-11  
    Data Type Registers ..... B-11  
    Data Units Registers ..... B-12  
Data and Alarm Registers ..... B-13  
    Data and Alarm Enable Registers ..... B-13  
    Enable Alarming for a Channel ..... B-15  
    Threshold Setup Registers ..... B-16  
        Setting the Alarm Threshold Value ..... B-17

## Index



# About this Manual

This manual describes the installation and operation of the Lighthouse REMOTE ActiveCount System.

## Text Conventions

**Note:** *A note appears in the sidebar to give extra information regarding a feature or suggestion.*

---

---

**WARNING:** *A warning appears in a paragraph like this and warns that doing something incorrectly could result in personal injury, damage to the instrument or loss of data.*

---

---

The following typefaces have the following meanings:

<i>italics</i>	Represents information not to be typed or interpreted literally. For example, <i>file</i> represents a file name. Manual titles are also displayed in italics.
<b>boldface</b>	Introduces or emphasizes a term.
Courier font	Indicates command syntax or text displayed by the diagnostic terminal.
<b>Bold Courier</b>	Indicates commands and information that you type.
<i>Helvetica Italics</i>	Indicates a comment on a command or text output.

Hexadecimal numbers are shown with the word "hex" or with a small "h" following the digits. For example:

hex 0D  
0Dh

## Additional Help

For more information about the Lighthouse REMOTE ActiveCount System, contact Lighthouse Worldwide Solutions.

Service and Support  
Tel: 1-800-945-5905 (USA Toll Free)  
Tel: 1-541-770-5905 (Outside of USA)  
techsupport@golighthouse.com



# *1*      *General Safety*

## **Safety Considerations**

Warnings and cautions are used throughout this manual. Familiarize yourself with the meaning of a warning before operating the particle sensor. All warnings will appear in the left margin of the page next to the subject or step to which it applies. Take extreme care when doing any procedures preceded by or containing a warning.

For further technical assistance, contact our Technical Support Team at 1-800-945-5905 (USA Toll Free), 1-541-770-5905 (Outside of USA) or at [techsupport@golighthouse.com](mailto:techsupport@golighthouse.com).



# 2

## Introduction

### Overview

This operating manual introduces you to the Lighthouse RAC Biological Air Sampler System. Included in this manual are instructions for installation, operation, communications and maintenance.

### Interchangeable Terms

Throughout this document, the REMOTE ActiveCount may be referred to as the *RAC System*, *RAC Controller* or *instrument*. For simplicity, these terms are interchangeable and mean the same thing.

### Description

The REMOTE ActiveCount is an active air sampling device that employs the impaction principle to impact particles bearing microbiological material onto a plate or petri dish loaded with nutrient agar. The RAC System is a 3-piece assembly consisting of a Controller, a Remote Switch and an Impactor that is designed to be a fixed point microbial monitoring device that assists users in automatically collecting microbial material at critical locations.

With a flow rate of 1CFM,  $\pm 10\%$ , the REMOTE ActiveCount is meant to be a component of a larger facility monitoring system.



Figure 2-1 REMOTE ActiveCount Biological Air Sampler

The Impactor (bottom mount or table mount) is installed at the sampling location using the tubing connected to the Impactor port.



Figure 2-2 Impactors

## REMOTE ActiveCount Specifications

Table 2-1 REMOTE ActiveCount Specifications

<b>Vacuum Requirement</b>	16inHg
<b>Flow Rate</b>	1.0CFM (28.3 LPM)
<b>Communication Modes</b>	RS-232, RS-485 Modbus
<b>LED Indications</b>	Status (Power, Flow, Sampling)
<b>Supporting Software</b>	LMS Express RT, LMS Pharma, LMS Professional
<b>Power</b>	+24VDC
<b>Enclosure</b>	Stainless Steel
<b>Dimensions</b>	Controller: 8.8"(L) x 5.0"(H) x 3.0"(W) [22.35 x 12.7 x 7.62 cm] Switch: 5.28"(L) x 2.80"(H) x .960"(W) [13.41 x 7.11 x 2.44 cm] Impactor: 4.41"(D), 2.1"(H) [11.2 cm, 5.3 cm]
<b>Weight</b>	Controller: 2.6 lbs. (1.2 kg) Switch: 0.59 lbs. (0.27 kg) Impactor: 4.4 lbs. (2.0 kg)

# 3

## *Getting Started*

### **Initial Inspection**

The RAC System is thoroughly inspected and tested at the factory and is ready for use upon receipt.

### **Unpacking**

It is presumed that when the shipment was received, the following took place:

1. The shipping container was inspected for damage.
2. If the container was damaged, the shipper was notified immediately.
3. The instrument was carefully inspected for broken parts, scratches, dents and other damage before use, even if the container appeared to be undamaged.
4. Any damages were reported to Lighthouse Technical Support at 800-945-5905 (USA Toll Free) or 541-770-5905 (Outside of USA) before proceeding.

Verify the contents of the package against the shipping list. If anything appears to be missing, please contact your sales representative at Lighthouse Worldwide Solutions immediately at 510-438-0500.

**To maintain your warranty, keep the undamaged shipping container and all packing material for reshipment of the instrument for servicing or repair. Order replacement containers and packing materials only from Lighthouse or a Lighthouse-authorized distributor.**

## Shipping Instructions

Should it become necessary to return the unit to the factory for any reason, contact Lighthouse Customer Service or visit our website, [www.golighthouse.com/rma](http://www.golighthouse.com/rma), and obtain a Return Merchandise Authorization (RMA) number. Reference this number on all shipping documentation and purchase orders. After receipt of the RMA number, follow the shipping instructions below:

---

---

**WARNING:** *If the instrument is damaged during a return shipment due to inadequate user packing, the warranty may be voided and may result in additional repairs being billed to the customer.*

---

---

1. Use the original container and packing materials whenever possible. Refer to [www.golighthouse.com/rma](http://www.golighthouse.com/rma) for detailed instructions. Remove attachments and package separately to prevent physical damage.
2. If the original container and packing materials are not available, wrap the unit in "bubble pack", surround with shock-absorbant material and place in a double-wall carton - the instrument should not rattle around when the carton is vigorously shaken. If the instrument is damaged during shipment due to inadequate user packing, the warranty may be voided and may result in additional repairs being billed to the customer. You may contact Lighthouse to purchase a replacement shipping container.
3. Seal the container or carton securely. Mark "FRAGILE" and write the Return Merchandise Authorization (RMA) number on any unmarked corner.
4. Return the instrument to the address provided by your Lighthouse representative or the RMA website.



## Installation

The RAC Controller and the Remote Switch can be mounted to a facility wall or customer equipment to allow sampling of critical locations. Mounting the controller to a wall will allow Grade A environments to be sampled directly and will allow the remote use of impactors and isokinetic probes.

**Note:** The RAC Controller and Remote Switch must be mounted on a flat vertical surface.

---

---

**WARNING:** AC power must be available within 3 feet of the mounting location if controller is wall mounted.

---

---

1. Ensure that power has been disconnected from the hub to which the RAC Controller will be connected.
2. Access the DIP switch and set switches 1 thru 5 to the address desired. Address 1 is the default address. See Figure 3-1.

**Note:** For default RS485 MODBUS operation switches 1 and 6 must be ON and switches 7 and 8 must be OFF.

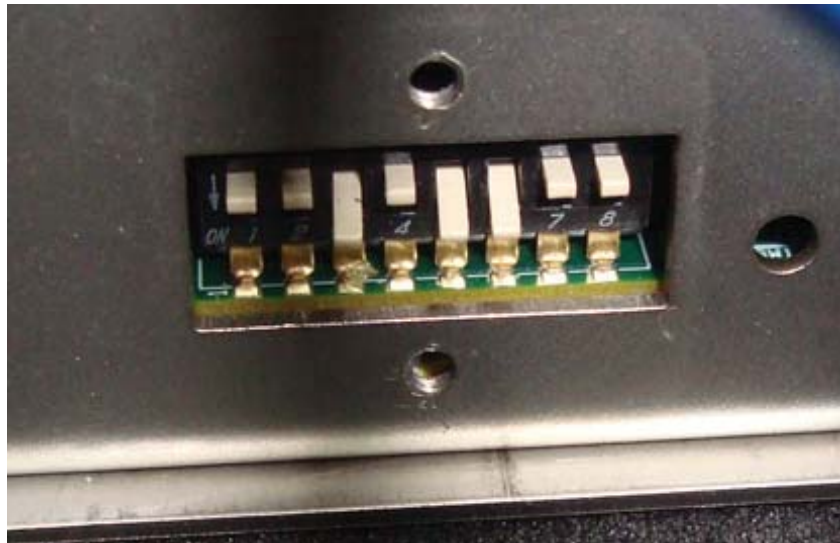


Figure 3-1 DIP Switch

**Note:** See Pages 3-5 thru 3-6 for DIP Switch definitions and addressing.

3. Once the controller and switch are mounted, install the tubing to the impactor and vacuum ports on the bottom of the controller. See Figure 3-2.



**Figure 3-2 Controller Ports**

4. Attach two Cat-5 Communication cables to the RJ-45 ports labeled "RS-232" and "Switch" on the bottom of the controller as shown in Figure 3-3.



**Figure 3-3 RJ-45 Connections**

## DIP Switch Settings

**Note:** Use a tool with a very small pointed tip to change DIP Switch positions.

## DIP Switch General Definitions

Table 3-1 provides the DIP switch settings for each position, including their descriptions. Each switch can be set in the following positions:

OFF (UP) = 0, ON (DOWN) = 1

**Table 3-1 DIP Switch Settings**

Position #	Description	Setting
1	Binary Bit 0	Addressing, OFF=1, ON=1
2	Binary Bit 1	Addressing, OFF=1, ON=1
3	Binary Bit 2	Addressing, OFF=1, ON=1
4	Binary Bit 3	Addressing, OFF=1, ON=1
5	Binary Bit 4	Addressing, OFF=1, ON=1
6	Communication Mode	Always ON for MODBUS ASCII communication
7	Communication Mode	Always OFF for proper operation
8	Communication Mode	Default OFF - when ON, records are not saved to buffer

## DIP Switch Addressing

**Note:** Because Address 0 is reserved for broadcasting in MODBUS RS-485 communications, Address 1 is set when all the DIP switches are OFF or when DIP switch 1 is ON. For MR Protocol, Address 0 is set when all DIP switches are OFF.

Table 3-2 details the addresses set by the binary DIP switches 1-6.

**Table 3-2 DIP Switch Addresses**

DIP SWITCHES 1 2 3 4 5 6	ADDRESS
1 0 0 0 0 0	1
0 1 0 0 0 0	2
1 1 0 0 0 0	3
0 0 1 0 0 0	4
1 0 1 0 0 0	5
0 1 1 0 0 0	6
1 1 1 0 0 0	7

**Table 3-2 DIP Switch Addresses**

<b>DIP SWITCHES 1 2 3 4 5 6</b>	<b>ADDRESS</b>
0 0 0 1 0 0	8
1 0 0 1 0 0	9
0 1 0 1 0 0	10
1 1 0 1 0 0	11
0 0 1 1 0 0	12
1 0 1 1 0 0	13
0 1 1 1 0 0	14
1 1 1 1 0 0	15
0 0 0 0 1 0	16
1 0 0 0 1 0	17
0 1 0 0 1 0	18
1 1 0 0 1 0	19
0 0 1 0 1 0	20
1 0 1 0 1 0	21
0 1 1 0 1 0	22
1 1 1 0 1 0	23
0 0 0 1 1 0	24
1 0 0 1 1 0	25
0 1 0 1 1 0	26
1 1 0 1 1 0	27
0 0 1 1 1 0	28
1 0 1 1 1 0	29
0 1 1 1 1 0	30
1 1 1 1 1 0	31

## RAC Controller RJ-45 Pinouts

The "RS232" port on the Controller has RJ-45 pinouts shown in Table 3-3.

**Table 3-3 RS232 Port- RJ-45 Pinouts**

RJ-45 Pin	Signal Name
1	RS-232 TX
2	RS-232 RX
3	RESERVED for future use
4	RS-485B
5	RS-485A
6	RESERVED for future use
7	RESERVED for future use
8	GND

**Note:** *The RAC Controller provides +24VDC from pin-7 and GND from pin-8 to pins 1 and 4 on the Switch Terminal block respectively.*

The Controller "Switch" port has RJ-45 pinouts shown in Table 3-4.

**Table 3-4 Switch Port - RJ-45 Pinouts**

RJ-45 Pin	Signal Name
1	RX IN
2	TX OUT
3	RESERVED for future use
4	RESERVED for future use
5	RESERVED for future use
6	RESERVED for future use
7	24VDC OUT
8	GND

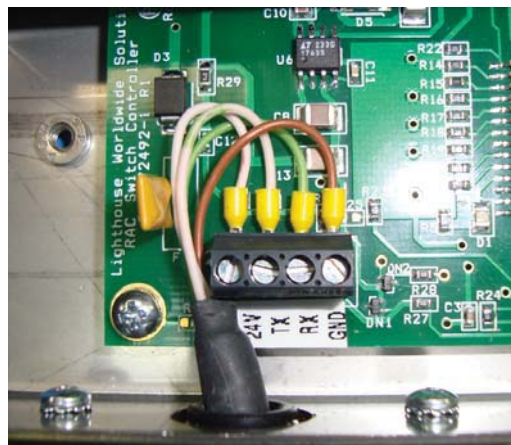
## Remote Switch RJ-45 Pinouts

Table 3-5 displays the terminal block pinouts for the Remote Switch.

**Table 3-5 Switch Connector - Terminal Block Pinouts**

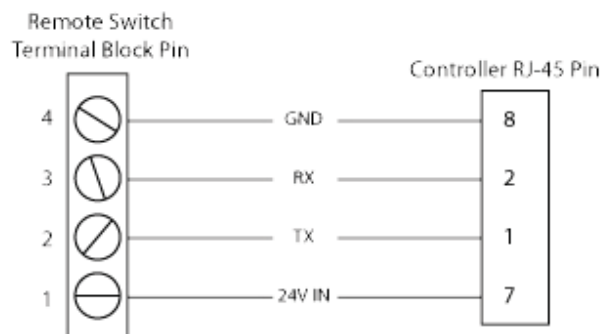
Pin	Signal Name
1	24V IN
2	TX OUT
3	RX IN
4	GND

Attach the Cat-5 Communication cable from the Controller Switch connector to the terminal block in the Remote Switch as shown in Figure 3-4.



**Figure 3-4 Terminal Block Wiring - Remote Switch**

Wire the cable according to the wiring diagram shown in Figure 3-5.



**Figure 3-5 Remote Switch Wiring**

**Note:** *The cable going to the Remote Switch must be connected to the receptacle inside the switch. The Lighthouse Installation Team will ensure that the switch is properly wired before the RAC System is activated.*

When the switch is wired correctly, the Power and Flow lights will illuminate as shown in Figure 3-6.

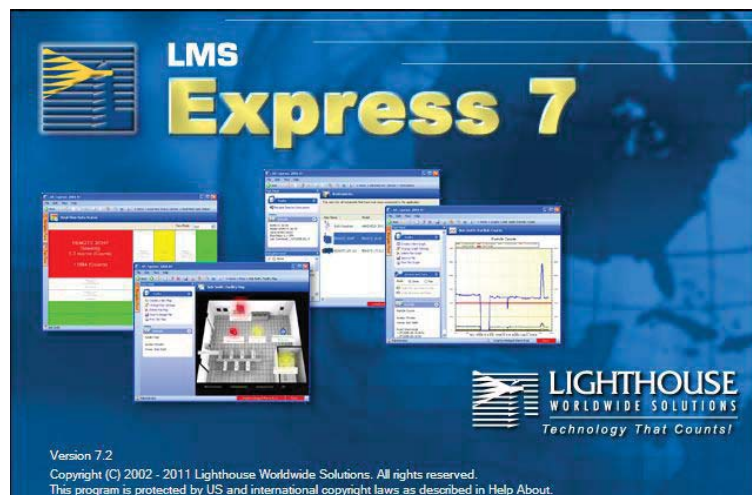


**Figure 3-6 Remote Switch**

Connect the Cat-5 Communication cable from the RAC Controller to a gateway or hub. Connect the vacuum tubing to a vacuum source and the impactor tubing to an impactor. Connect the power supply to the controller.

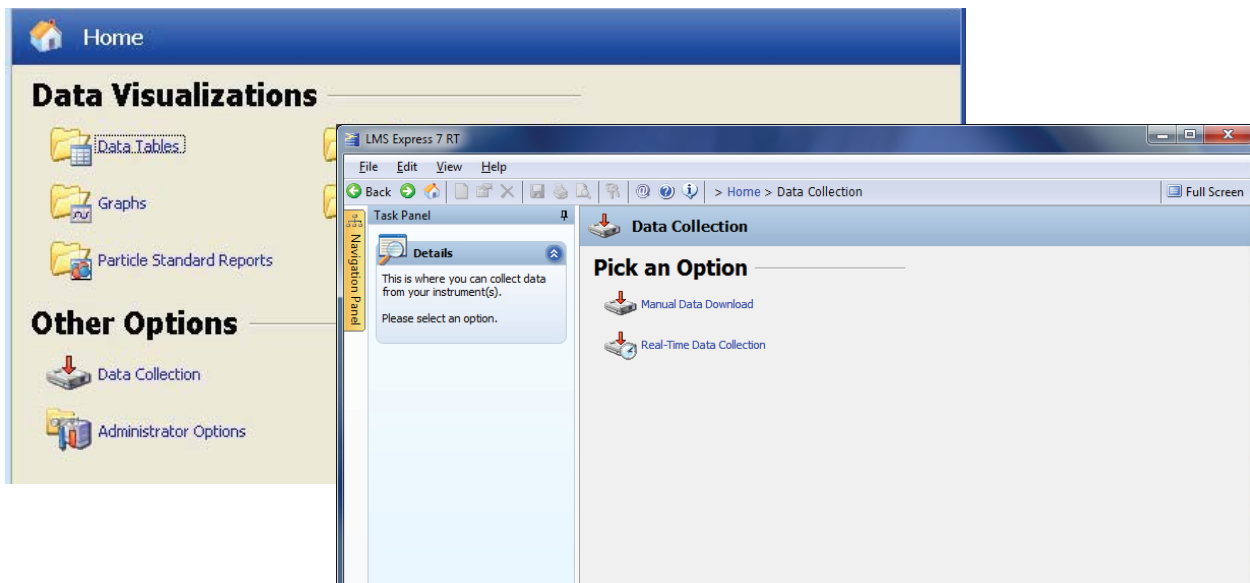
## Configuring the RAC in LMS Express RT

On a PC that is connected to a gateway or hub, start LMS Express. See Figure 3-7.



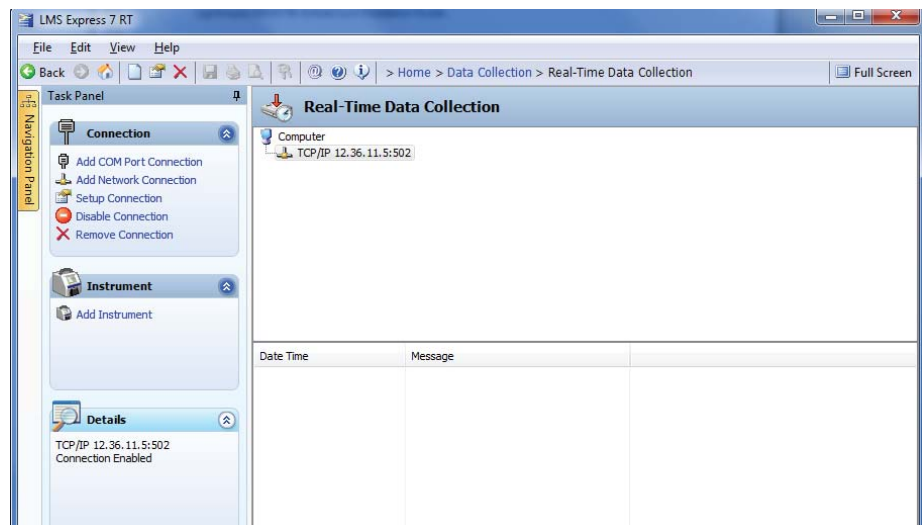
**Figure 3-7 LMS Express 7**

Choose *"Data Collection"* on the LMS Express home page under the heading **Other Options**. On the **Data Collection** page, choose *"Real-Time Data Collection"*. See Figure 3-8.



**Figure 3-8 Data Collection & Real-Time Data Collection**

Select *Add Network Connection* in the **Connection Task Panel** and enter the IP address. A COM port can also be selected and configured. See Figure 3-9.

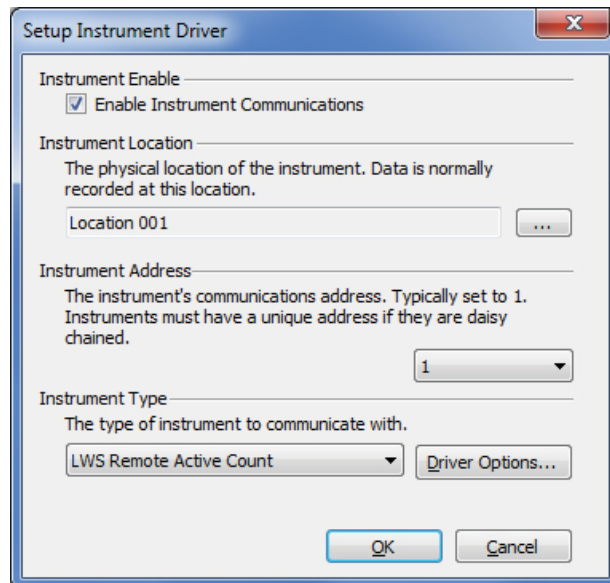


**Figure 3-9 Add a Network Connection**

Select *Add Instrument* in the **Instrument Task Panel** to set up the instrument driver.

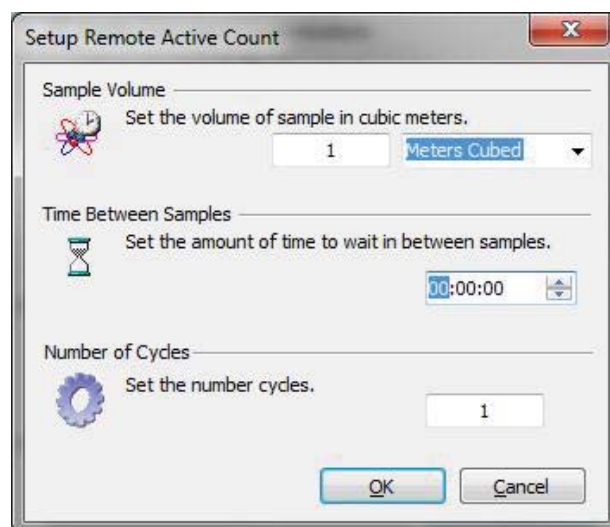


In the **Setup Instrument Driver** dialog box, confirm that the **Instrument Enable** checkbox is active. Select an instrument location for the **Instrument Location**, leave the **Instrument Address** at *1* and select the *LWS Remote Active Count* from the **Instrument Type** drop-down menu. See Figure 3-10.

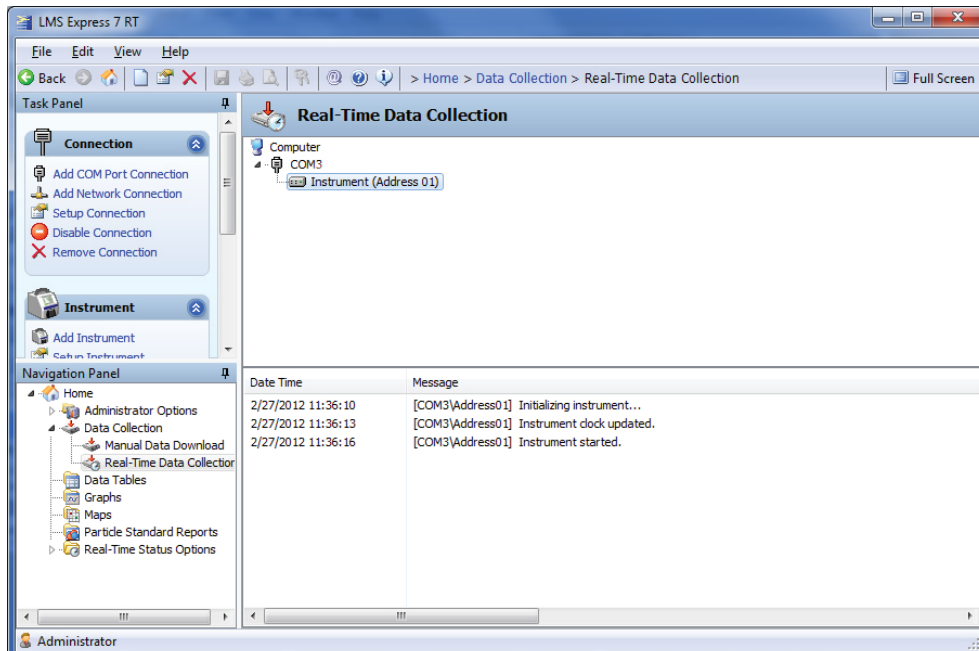


**Figure 3-10 Setup Instrument Driver**

Select the **Driver Options** button. Verify the **Sample Volume** is set to *1* and *Meters Cubed*. Leave the **Time Between Samples** at *zero* and the **Number of Cycles** at *1* and press OK to return to Setup dialog. Select OK again to start the RAC System on a cycle. See Figure 3-11 & Figure 3-12.



**Figure 3-11 Setup Remote Active Count**



**Figure 3-12 RAC System in Cycle**

After one complete cycle, the instrument is now configured and can be controlled through LMS Express RT or by the Remote Switch.

### Remote Switch Operation

The Remote Switch operates the Controller after the unit has been configured by LMS Express. See Figure 3-13.



**Figure 3-13 Remote Switch Operation**

- Pressing the Remote Switch once starts the Remote ActiveCount. The Sampling light will illuminate.
- Pressing the switch a second time pauses the operation.
- Pressing the switch a third time will resume the sample. Holding the button for 3-5 seconds at any part of the process will stop the sample.

## Configure Flow Settings

To configure the flow settings for the RAC System, perform the following steps:

**Note:** *The Impactor Assembly utilizes a critical orifice to achieve the desired median flow.*

*It is recommended that the Median flow setting be configured with the impactor installed.*

1. Ensure that the power is removed from the controller.
2. Remove the DIP Switch Cover Plate to expose the DIP Switch. Verify DIP SW 1 and 6 are ON for MODBUS mode (default setting). If any address other than address 1 is required, set DIP SW 1 through 5 to the desired address.
3. *See Pages 3-5 and 3-6 for DIP Switch definitions and addressing.*
4. Attach a flow meter to the tubing connected to the Vacuum Port on the bottom of the RAC Controller. Connect the other end of the flow meter to a needle valve that is attached to a vacuum source.
5. Attach the locking power jack to the Controller as shown in Figure 3-14. Confirm that the Power LED is on.



Figure 3-14 24VDC Power Jack

6. Confirm that the Remote Switch is connected to the Switch Port and that the Power and LED is on. See Figure 3-15.



**Figure 3-15 Remote Switch with Power**

7. Press and hold the Start/Stop button on the Remote Switch while applying power. Hold at least for 10 seconds then release the button. The Power LED should start blinking for a few seconds to indicate that the unit is in Service Mode. The user can now configure the flow settings.
8. When the LED stops blinking, the median (28.3 lpm) flow setting can be set. Adjust the needle valve at the vacuum source until the flow meter reads 28.3 lpm (1 CFM) and is steady. Briefly press the Start/Stop button to save.
9. When the LED stops blinking, the upper flow setting can be set. Remove the Impactor Assembly from the Impactor tubing and adjust the needle valve at the vacuum source until the flow meter reads 31.1 lpm (1.1 CFM) and is steady. Briefly press the Start/Stop button to save.
10. When the LED stops blinking, the lower flow setting can be set. Adjust the needle valve at the vacuum source until the flow meter reads 25.5 lpm (0.9 CFM) and is steady. Briefly press the Start/Stop button to save.
11. When the LED stops blinking, the settings have been saved. Remove the power cord and reinstall the impactor. Re-attach the power cord and press the start button and run one sample. Verify that the flow reads 28.3 lpm. Remove the power cord when the sample is complete.

# 4

# Communications

## Configuring with the MODBUS Protocol

The RAC System uses Modbus Register Map v1.49. The product name needs to be "VIABLE" for LMS Express to recognize it as a RAC.

**Note:** Sample time must be calculated for the specific sample volume desired based on 1CFM flow. Sample time calculations are performed and written to the Remote ActiveCount by LMS Express.

Samples with multiple cycles must have the individual sample time calculated for each sample.

## Configure the RAC System

Table 4-1 displays the MODBUS commands to configure the RAC system.

**Table 4-1 Configure Commands**

Value	Register	Action
-1	40025	Saves all writable 40025 register values to the Data Record Index.
<Location Number>	40026	Saves all writable 40026 register values to instrument Location.
0	40029	Set Initial Delay A to register 40029.
0	40030	Set Initial Delay B to register 40030.
<Hold Time High>	40031	Set Hold Time High to register 40031.
<Hold Time Low>	40032	Set Hold Time Low to register 40032.
<Sample Time High>	40033	Set Sample Time High to register 40033.
<Sample Time Low>	40034	Set Sample Time Low to register 40034.
<Clock High>	40035	Set Clock High to register 40035.
<Clock Low>	40036	Set Clock Low to register 40036.
13	40002	Saves Clock settings to register 40002.
<Number of Cycles>	40053	Set the number of cycles to register 40053.

## Operating the RAC System

The Remote ActiveCount can be operated by using the MODBUS Protocol. The applicable action commands are listed in Table 4-2.

**Table 4-2 Action Commands**

Value	Register	Action
1	40002	Saves all writable 40002 register values to the EEPROM.
5	40002	Enable Remote Mode. Locks out the instrument's user interface. Can only change instrument parameters via MODBUS.
11	40002	Instrument Start. Uses defined Initial Delay, Hold Time, Sample Interval and counting mode. Instrument executes samples and holds until an Instrument Stop command is issued. This command will start the pump.
12	40002	Instrument Stop. Aborts current sample. Stops pump. Stops data collection.

## Access RAC Information

Table 4-3 displays the MODBUS read commands to access RAC information.

**Table 4-3 Read Commands**

Value	Register	Action
50	40001	Read Device Information: Parse through device information. Verify "VIABLE" in the product name.
1	40003	Read Device Status
2	40005	Read Device Serial Number
74	30001	Get Data Record
72	41001	Get Data Types
72	42001	Get Data Units
72	43001	Get Data Enables

# A *Limited Warranty*

## **Limitation Of Warranties:**

- A. Lighthouse Worldwide Solutions (LWS) warrants that all equipment shall be free from defects in material and workmanship under normal use for a period of two years from date of shipment to Buyer except that LWS does not warrant that operation of the software will be completely uninterrupted or error free or that all program errors will be corrected. Buyer shall be responsible for determining that the equipment is suitable for Buyer's use and that such use complies with any applicable local, state, or federal law. Provided that Buyer notifies LWS in writing of any claimed defect in the equipment immediately upon discovery and any such equipment is returned to the original shipping point, transportation charges prepaid, within two years from date of shipment to Buyer and upon examination LWS determines to its satisfaction that such equipment is defective in material or workmanship, i.e. contains a defect arising out of the manufacture of the equipment and not a defect caused by other circumstances, including, but not limited to accident, misuse, unforeseeable use, neglect, alteration, improper installation, improper adjustment, improper repair, or improper testing, LWS shall, at its option, repair or replace the equipment, shipment to Buyer prepaid. LWS shall have reasonable time to make such repairs or to replace such equipment. Any repair or replacement of equipment shall not extend the period of warranty. If the Instrument is modified or in any way altered without the explicit written consent of LWS then the warranty is null and void. This warranty is limited to a period of two years, except as noted below, without regard to whether any claimed defects were discoverable or latent on the date of shipment. The length of warranty for pumps in hand held particle counters is one (1) year. Batteries and accessories with all products are warranted for one (1) year. Fuses and purge filters carry no warranty. If a third party battery is used in the product, the product warranty is null and void. If the battery is charged by a third party battery charger the battery warranty is null and void.
- B. If Buyer shall fail to pay when due any portion of the purchase price or any other payment required from Buyer to LWS under this contract or otherwise, all warranties and remedies granted under this Section may, at LWS's option, be terminated.
- C. THE FOREGOING WARRANTY IS EXCLUSIVE AND IN LIEU OF ALL OTHER REPRESENTATIONS, WARRANTIES AND COVENANTS, EXPRESS OR IMPLIED WITH RESPECT TO THE EQUIPMENT AND ANY DEFECTS THEREIN OF ANY NATURE WHATEVER, INCLUDING AND WITHOUT LIMITATION WARRANTIES OF MERCHANTABILITY OR FITNESS FOR A PARTICULAR PURPOSE. LWS SHALL NOT BE LIABLE FOR, AND BUYER ASSUMES ALL RISK OF, ANY ADVICE OR FAILURE TO PROVIDE ADVICE BY LWS TO BUYER REGARDING THE EQUIPMENT OR BUYERS USE OF THE SAME. UNDER NO CIRCUMSTANCES SHALL LWS BE LIABLE TO BUYER UNDER ANY TORT, NEGLIGENCE,

STRICT LIABILITY, OR PRODUCT LIABILITY CLAIM AND BUYER AGREES TO WAIVE SUCH CLAIMS. LWS's SOLE AND EXCLUSIVE LIABILITY AND BUYERS SOLE AND EXCLUSIVE REMEDY, FOR ANY NONCONFORMITY OR DEFECT IN THE PRODUCTS OR ANYTHING DONE IN CONNECTION WITH THIS CONTRACT, IN TORT, (INCLUDING NEGLIGENCE), CONTRACT, OR OTHERWISE, SHALL BE AS SET FORTH IN THE SUBSECTION A HEREOF AS LIMITED BY SUBSECTION B HEREOF. THIS EXCLUSIVE REMEDY SHALL NOT HAVE FAILED OF ITS ESSENTIAL PURPOSE (AS THAT TERM IS USED IN THE UNIFORM COMMERCIAL CODE) PROVIDED THAT THE SELLER REMAINS WILLING TO REPAIR OR REPLACE DEFECTIVE EQUIPMENT (AS DEFINED IN SUBSECTION A) WITH A COMMERCIALY REASONABLE TIME AFTER RECEIVING SUCH EQUIPMENT. BUYER SPECIFICALLY ACKNOWLEDGES THAT SELLER'S PRICE FOR THE EQUIPMENT IS BASED UPON THE LIMITATIONS OF LWS'S LIABILITY AS SET FORTH IN THIS CONTRACT.

## **Warranty Of Repairs After Initial Two (2) Year Warranty:**

- A. Upon expiration of the initial two-year warranty, all parts and repairs completed by an authorized Lighthouse repair technician are subject to a six (6) month warranty.
- B. Other than the above, LWS makes no warranty of any kind, expressed or implied, except that the products manufactured and sold by LWS shall be free from defects in materials and workmanship and shall conform to LWS's specifications; Buyer assumes all risk and liability resulting from use of the products whether used singly or in combination with other products. If instrument is modified or in any way altered without the explicit written consent of LWS, then the warranty is null and void.
- C. WARRANTY REPAIRS SHALL BE COMPLETED AT THE FACTORY, BY AN AUTHORIZED SERVICE LOCATION, BY AN AUTHORIZED SERVICE TECHNICIAN, OR ON SITE AT BUYER'S FACILITY BY A LIGHTHOUSE AUTHORIZED EMPLOYEE. BUYER PAYS FREIGHT TO FACTORY; SELLER WILL PAY STANDARD RETURN FREIGHT DURING THE WARRANTY PERIOD. BUYER MAY SELECT A FASTER METHOD OF SHIPMENT AT ITS OWN EXPENSE.





# B

## *Remote ActiveCount MODBUS Register Map v1.49*

### **COMM Settings**

Lighthouse instruments using MODBUS require the following communications settings as shown in Table B-1.

**Table B-1 MODBUS Communications Settings**

<b>Baud Rate</b>	19200
<b>Data Bits</b>	8
<b>Stop Bits</b>	1
<b>Parity</b>	None
<b>Hardware Protocol</b>	RS485, USB and Ethernet
<b>Software Protocol</b>	MODBUS ASCII (supports upper/lower case) MODBUS TCP

The MODBUS slave address is set on the particle counter.

### **Supported MODBUS Commands**

**Table B-2 MODBUS Registers**

<b>Hex Command</b>	<b>Description</b>
03	Read Holding Registers
04	Read Input Registers
06	Write Single Holding Register

See [www.modbus.org](http://www.modbus.org) for documentation on how to use these commands.

## Register Map      Sensor Settings Registers

Instrument settings are stored in holding registers (the 4xxxx series), which are mostly read/writable. Not all holding registers are writable. Table B-3 describes the contents of these registers.

**Table B-3 Sensor Settings Registers**

Register	Data Type	Description
40001	unsigned integer	MODBUS register map version. Matches the version number of this document. Major version digits are hundreds. Minor version digits are tens and ones. For example, v1.35 = 135d = 0087h.
40002	unsigned integer	Command register. Makes the counter execute a command. See the description of this register in the table below.
40003	unsigned integer	Device Status. [bit 0=RUNNING, bit 1=SAMPLING, bit 2=NEW DATA, bit 3=DEVICE ERROR, bit 12=FLOW STATUS]
40004	unsigned integer	Firmware version. Major version digits are hundreds. Minor version digits are tens and ones. For example, 210 = v2.10.
40005	unsigned integer	Serial Number [high]
40006	unsigned integer	Serial Number [low]
40007	ASCII string	Product Name char[0], char [1] (NULL terminated string)
40008	ASCII string	Product Name char[2], char [3]
40009	ASCII string	Product Name char[4], char [5]
40010	ASCII string	Product Name char[6], char [7]
40011	ASCII string	Product Name char[8], char [9]
40012	ASCII string	Product Name char[10], char [11]
40013	ASCII string	Product Name char[12], char [13]
40014	ASCII string	Product Name char[14], char [15]
40015	ASCII string	Model Name char[0], char [1] (NULL terminated string)
40016	ASCII string	Model Name char[2], char [3]
40017	ASCII string	Model Name char[4], char [5]
40018	ASCII string	Model Name char[6], char [7]
40019	ASCII string	Model Name char[8], char [9]

**Table B-3 Sensor Settings Registers**

<b>Register</b>	<b>Data Type</b>	<b>Description</b>
40020	ASCII string	Model Name char[10], char [11]
40021	ASCII string	Model Name char[12], char [13]
40022	ASCII string	Model Name char[14], char [15]
40023	unsigned integer	Flow Rate. Divide by 100 to get rate in CFM. For example, 100 = 1CFM.
40024	unsigned integer	Record Count. Total number of records stored in the counter.
40025	unsigned integer	Record Index. Zero based index to data in 30xxx register series. Must be lower than the record count (register 40024). Set this index to expose a counter's record in the 30xxx registers. Set to -1 to retrieve last record stored in the counter.
40026	unsigned integer	Location number. Specifies location of the instrument. Must be 1 to 200 (maps to location names associated with registers 40200 - 40999).
40027	signed integer	Real Time Clock (RTC) [high]. Updates instrument's real-time clock. Works in conjunction with 40028. Displays date and time, in number of seconds since midnight, 1/1/1970. Can be generated by ANSI C/C++ time() function.
40028	signed integer	Real Time Clock [low]
40029	unsigned integer	Initial Delay [high]. Works in conjunction with 40030. Number of seconds to wait before starting the first sample. Max value is 359,999, which equals 99h 59m 59s.
40030	unsigned integer	Initial Delay [low]
40031	unsigned integer	Hold Time [high]. Works in conjunction with 40032. Number of seconds to wait between sample periods. Max value is 359,999, which equals 99h 59m 59s.
40032	unsigned integer	Hold Time [low]
40033	unsigned integer	Sample Time [high]. Works in conjunction with 40034. Number of seconds to sample. Max value is 86,399, which equals 23h 59m 59s.
40034	unsigned integer	Sample Time [low]
40035	unsigned integer	Data Set [high]. Works in conjunction with 40036. Data entered here is applied to the device through the command register.
40036	unsigned integer	Data Set [low]

**Table B-3 Sensor Settings Registers**

<b>Register</b>	<b>Data Type</b>	<b>Description</b>
40037	unsigned integer	Alarm Mode. Type of alarming performed
40038	unsigned integer	Alarm Parameter. Control parameter for given alarm mode.
40039	unsigned integer	Laser Reference Voltage (millivolts)
40040	unsigned integer	View Volume. Divide by 100 to get percentage. For example: 6550d = 65.50%
40041	ASCII string	Flow Unit. Defines unit as cfm, lpm, mlpm char[0], char[1] (NULL terminated string).
40042	ASCII string	Flow Unit. char[2], char[3]
40043	unsigned integer	Calibration Reference Voltage (millivolts)
...		
40049	signed integer	Printer Options
40050	signed integer	Device Options
40053	unsigned integer	Cycles Set Sets number of cycles.
...		
40076	ASCII string	Current Status [high] - preview of register 30007
40077	ASCII string	Current Status [low] - preview of register 30008
...		
40199	unsigned integer	Number of available alphanumeric location names (0 means alphanumeric names are not supported).
40200	ASCII string	Location_1_char[0], char[1] (NULL terminated string)
40201	ASCII string	Location_1_char[2], char[3]
40202	ASCII string	Location_1_char[4], char[5]
40203	ASCII string	Location_1_char[6], char[7]
...		
40996	ASCII string	Location_200_char[0], char[1] (NULL terminated string)
40997	ASCII string	Location_200_char[2], char[3]
40998	ASCII string	Location_200_char[4], char[5]
40999	ASCII string	Location_200_char[6], char[7]

Alarm Mode (40037) defines the type of calculation performed to define an alarm condition. Alarm Mode = 0 corresponds to conventional threshold alarming; channel bit set if threshold exceeded for that given channel.

Alarm Parameter (40038) defines additional parameters that may be needed in defining an alarm mode.

Printer Options (40049) displays the configuration of the instrument's printer function.

**Table B-4 Printer Options**

Bit	Description
0	Unused - non-writeable
1	Print on Sample (1=Enabled, 0=Disabled)
2-15	Reserved

If Bit-1 of Register 40049 is set, the instrument will print the last recorded data at the end of each sample. This feature cannot be enabled if the the *One Second Data Update* feature is enabled.

**Device Options (40050)** displays the instrument's device configuration.

**Table B-5 Device Options**

Bit	Description
0	Fast Download (1=Enabled, 0=Disabled) non-writeable
1	One Second Data Update (1=Enabled, 0=Disabled)
2-15	Reserved

If bit 0 of Register 40050 is set, it indicates that the instrument is capable of Fast Download.

If Bit 1 of Register 40050 is set, the instrument will display and update the data registers every second. No data will be recorded in the data buffer. Enabling this feature disables the Print on Sample feature.

Registers 40200-40999 are reserved for eight character names associated with location index values. Thus the name for location =3 would be located at registers 40208-40211. Up to two hundred locations can be specified.

Register 40199 indicates the number of location names supported on this device.

## Device Status

The Device Status register (40003) displays the current status of the device.

**Table B-6 Device Status**

Bit	Description
0	<b>RUNNING:</b> Set when a start command is executed remotely via Command 9 (manual start) or Command 11 (instrument start) or through the user interface. The flag will remain set until a stop command is executed.
1	<b>SAMPLING:</b> This is set only when the instrument is actually sampling data that is to be recorded. Caution must be used in sending a command during this time that may invalidate current sample.
2	<b>NEW DATA:</b> Set to 1 to indicate that a new data record has been recorded and it hasn't been read via modbus yet. When a data record has been read via modbus (registers 30001 to 30999), then this flag is reset to zero.
12	<b>FLOW STATUS:</b> Set to 1 when unit's flow is out of spec, else 0.

## Command Register

The Command Register (40002) is used to make the device perform an action. The register performs an action when an integer value is written to it. The action is completed when the device sends a MODBUS response. When this register is read, it always returns a zero.

**Table B-7 Command Register**

Value	Action
1	Saves all writable 4xxxx register values to the EEPROM.
2	Reserved for future use.
3	Clears the Data Buffer. Record count is set to zero.
4	Saves the instrument parameters in the 40xxx registers to the EEPROM. Parameters include Sample Time, Hold Time, Initial Delay, and Location.
5	Enable Remote Control. Locks out the instrument's user interface. Can only change instrument parameters via MODBUS.

**Table B-7 Command Register**

<b>Value</b>	<b>Action</b>
6	Enable Local Control. Unlocks the instrument's user interface. Instrument changes can be made at the device itself or through MODBUS.
7	Start local pump, if applicable - perform before 9 below.
8	Stop pump, if applicable - perform after 10 below.
9	Manual Start. The instrument samples continuously until it receives a Manual Stop command. Ignores local timing parameters. Sets Sample Time for data record to equal the time interval between the Manual Start and Manual Stop command. If applicable to device, does not start pump.
10	Manual Stop. Stops sampling. Records counts since Manual Start.
11	Instrument Start (Automatic Counting). Uses defined Initial Delay, Hold Time, Sample Interval and counting mode. Instrument executes samples and holds until an Instrument Stop command is issued. For instruments with pumps, this command will start the pump.
12	Instrument Stop. Aborts current sample. Stops pump, if applicable. Stops data collection.
13	Set Real Time Clock. Writes "Data Set" values (from Registers 40035 & 40036) to the local Real Time Clock. New time value is saved.
...	
192	Changes instrument baud rate to 19200K upon command execution.
576	Changes instrument baud rate to 57600K upon command execution.
1152	Changes instrument baud rate to 115200K upon command execution.

## Data Registers

Data is stored in the input registers (30xxx series), which are read-only. All data items are four bytes long and are stored across two registers. Byte and word order for integer data is big-endian. Thus, data items are formed by placing the high bytes in front of the low bytes.

Example:

<High Bytes><Low Bytes> = <4 Byte Data Item>

IEEE floating point has big-endian byte order and little-endian word order. Thus, analog data items are formed by placing the low bytes in front of the high bytes.

Example:

<Low Bytes><High Bytes> = <4 Byte Data Item>

Not all particle and analog channels are necessarily active. Retrieving data from an inactive channel returns garbage. See the Data Enable Registers section of this document for details on how to record data from active channels.

This entire series of registers represents one data record in the device. The Record Index Register (40025) must be changed to index other records here.

The first record in the data buffer is located at Index=0. The most recently saved value is at Index=-1.

**Table B-8 Data Registers**

Register	Data Type	Description
30001	signed integer	Timestamp [high] (# of seconds since midnight, 1/1/1970)
30002	signed integer	Timestamp [low]
30003	unsigned integer	Sample Time [high] (In seconds)
30004	unsigned integer	Sample Time [low]
30005	signed integer	Location [high] (Place where data was recorded)
30006	signed integer	Location [low]
30007	unsigned integer	Data Status [high]
30008	unsigned integer	Data Status [low]



**Table B-8 Data Registers**

<b>Register</b>	<b>Data Type</b>	<b>Description</b>
30009	unsigned integer	Particle Channel 1 [high]
30010	unsigned integer	Particle Channel 1 [low]
30011	unsigned integer	Particle Channel 2 [high]
30012	unsigned integer	Particle Channel 2 [low]
30013	unsigned integer	Particle Channel 3 [high]
30014	unsigned integer	Particle Channel 3 [low]
30015	unsigned integer	Particle Channel 4 [high]
30016	unsigned integer	Particle Channel 4 [low]
30017	unsigned integer	Particle Channel 5 [high]
30018	unsigned integer	Particle Channel 5 [low]
30019	unsigned integer	Particle Channel 6 [high]
30020	unsigned integer	Particle Channel 6 [low]
30021	unsigned integer	Particle Channel 7 [high]
30022	unsigned integer	Particle Channel 7 [low]
30023	unsigned integer	Particle Channel 8 [high]
30024	unsigned integer	Particle Channel 8 [low]
...		
30074	unsigned int	Valid particle channels
30076	unsigned int	Alarm Flags - Particle Channels

**Note:** *Particle data is always a cumulative raw count regardless of the instrument's settings.*

The timestamp field indicates when the data record was recorded. Timestamps are stored as the number of seconds since 1/1/1970, the Unix time epoch. This value can be written directly into a C/C++ time\_t data type to be used by ANSI C time functions.



## Alarm Flags in Channels (30076)

Register 30076 represents the flag bits corresponding to particle channels that have exceeded the threshold [Threshold High Registers (45xxx series)] based on alarm mode.

## Data Type Registers

**Note:** *All data records have the same data types assigned to them. The user does not have to read the data type registers for every record.*

The 41xxx register series is used to identify the type of data items in the 30xxx series. The Data Type registers run in parallel with the Data Registers. For example, Data Register 30041's Data Type register is 41041.

Data Types are assigned 4 ASCII characters across 2 registers. If a Data Type string contains less than 4 characters, then the rest of the string is padded with NULL characters. Note that a Data Type using all four characters will not end with a NULL character.

**Table B-10 Data Types**

String	Description
TIME	Timestamp
STIM	Sample Time
SVOL	Sample Volume
LOC	Location
STAT	Status
TEMP	Temperature
RH	Relative Humidity
AIRV	Air Velocity
DPRS	Differential Pressure
ESD	Electrostatic Discharge
FLOW	Flow Rate
LASV	Laser Voltage
VOLT	Voltage
PRES	Pressure

**Note:** *Only Particle data types have numbers in their strings.*

Particle data items are entered as shown in Table B-11. They contain numbers, sometimes a space and sometimes a period used as a decimal point. These entries are used to identify particle channel sizes and are always expressed in microns. These types represent raw counts only.

**Table B-11 Examples of Particle Data Items**

String	Description
0.3	Particle type of size 0.3 micron
1.0	Particle type of size 1.0 micron
20.0	Particle type of size 20.0 micron
.015	Particle type of size 0.015 micron or 15 nanometer

## Data Units Registers

The 42xxx register series identifies the units used by data items in the 30xxx series. These registers run in parallel with the Data Registers. For example, Data Register 30010's Units Register is 42010.

**Note:** *Not all data types have units.*

Units are stored as 4 character ASCII strings across 2 registers. If the Units string contains less than 4 characters or no characters at all, the rest of the string is padded with NULLs.

*LWS Particle Counters may use units not on the table.*

The table below shows units that may be sent by the device. Some of these units are not currently used but are reserved for future use.

**Table B-12 Data Units**

Units	Description	Units	Description
#	Count (For Particles)	ft/m	Feet per minute
%	Percent	m/s	Meters per second
s	Seconds	"H2O	Inches of water
min	Minutes	"Hg	Inches of mercury
hour	Hours	mmWa	Millimeters of water
F	Fahrenheit	mmHg	Millimeters of mercury
C	Celsius	cmHg	Centimeters of mercury
K	Kelvin	Pa	Pascals
ft	Feet	kPa	Kilopascals

**Table B-12 Data Units**

Units	Description	Units	Description
m	Meters	Bar	Bar
ft^2	Square feet	mBar	Milli-bar
m^2	Square meters	V	Volts
ft^3	Cubic feet	mV	Milli-volts
m^3	Cubic meters	A	Amperes
L	Liters	mA	Milli-amps
CFM	Cubic feet per minute	Ohm	Ohms
CMM	Cubic meters per minute	mOhm	Milli-ohm
L/m	Liters per minute	p/f3	Particles per cubic foot
p/m3	Particles per cubic meter	LPM	Liters per minute
PCT	Percent	MLPM	Milliliters per minute
SEC	Seconds	IHG	Inches of mercury
p/L	Particles per liter	p/ml	Particles per milliliter

## Data and Alarm Registers

### Data and Alarm Enable Registers

The Data and Alarm Enable input registers (43xxx series) are read/write. All enable data items are 4 bytes long and are stored across 2 registers. Byte and word ordering is big-endian. Thus, data items are formed by placing the high bytes in front of the low bytes. For example:

<High Bytes><Low Bytes> = <4 Byte Data Item>

The 43xxx register series is used to determine which particle data channel is ENABLED and which are set to ALARM ENABLE. These registers supersede the older Data Enable Registers (31xxx) which have been rendered obsolete.

**Table B-13 Enable/Disable Bits**

Bit	Description
0	DATA ENABLE (0=disable; 1=enable)
1	ALARM ENABLE (0=disable; 1=enable)

These registers run in parallel with the data registers (30xxx series). For example, data register 30010's enable register would be 43010. Data register 30016's enable register would be 43016.

**Note:** *Alarm Enable currently only works for Particle Channels.*

The user can enable multiple particle channels for alarming at the same time.

Particle data registers for the Enable setting start at 43009 for the high word and 43010 for the low word for particle channel 1.

**Table B-14 Alarm Enable Registers**

Register	Data Type	Description
43009	unsigned int	Enable for Particle Channel 1 [high] (smallest particle size starts here)
43010	unsigned int	Enable for Particle Channel 1 [low]
43011	unsigned int	Enable for Particle Channel 2 [high]
43012	unsigned int	Enable for Particle Channel 2 [low]
43013	unsigned int	Enable for Particle Channel 3 [high]
43014	unsigned int	Enable for Particle Channel 3 [low]
43015	unsigned int	Enable for Particle Channel 4 [high]
43016	unsigned int	Enable for Particle Channel 4 [low]
43017	unsigned int	Enable for Particle Channel 5 [high]
43018	unsigned int	Enable for Particle Channel 5 [low]
43019	unsigned int	Enable for Particle Channel 6 [high]
43020	unsigned int	Enable for Particle Channel 6 [low]
43021	unsigned int	Enable for Particle Channel 7 [high]
43022	unsigned int	Enable for Particle Channel 7 [low]
43023	unsigned int	Enable for Particle Channel 8 [high]
43024	unsigned int	Enable for Particle Channel 8 [low]
43041	unsigned int	Enable for Analog Channel 1 [high]
43042	unsigned int	Enable for Analog Channel 1 [low]
43043	unsigned int	Enable for Analog Channel 2 [high]
43044	unsigned int	Enable for Analog Channel 2 [low]

**Table B-14 Alarm Enable Registers**

<b>Register</b>	<b>Data Type</b>	<b>Description</b>
43045	unsigned int	Enable for Analog Channel 3 [high]
43046	unsigned int	Enable for Analog Channel 3 [low]
43047	unsigned int	Enable for Analog Channel 4 [high]
43048	unsigned int	Enable for Analog Channel 4 [low]

### Enable Alarming for a Channel

To enable alarming on the third particle channel, the user would enable Bit 1 for register 43014.

To disable alarming on the third channel and enable alarming on the second channel, disable Bit 1 for register 43014 and enable Bit 1 for register 43012.

To disable alarming completely, disable Bit 1 for register 43012. Now, no channels are enabled for alarms.

**Table B-15 Example of Alarming on Channel 2**

<b>Registers</b>	<b>Particle Channel</b>	<b>Bit 1 Enabled</b>
43009 - 43010	1	0
43011 - 43012	2	1
43013 - 43014	3	0
43015 - 43016	4	0
43017 - 43018	5	0
43019 - 43020	6	0
43021 - 43022	7	0
43023 - 43024	8	0

Use the Threshold registers to set the alarm threshold value. This is described in the next section.

## Threshold Setup Registers

Threshold data is stored in the input registers in the 45xxx series which are read/write. All threshold data items are 4 bytes long and are stored across 2 registers. Byte and word ordering is big-endian. Thus, data items are formed by placing the high bytes in front of the low bytes. For example:

<High Bytes><Low Bytes> = <4 Byte Data Item>

For particle channels, the threshold value is a 32-bit unsigned integer. If the data value exceeds the threshold value and the alarm is enabled for that channel, the threshold flag in the Data Status register (30007-30008, bit 4) is set.

**Note:** *The table below shows the registers for an 8 channel particle counter. Counters with fewer channels do not use the extra registers. The smallest particle channel starts at the xxx09 position.*

The threshold registers (45xxx series) run in parallel with the data registers (30xxx series). For example, data register 30010's corresponding threshold register would be 45010. Data register 30016's threshold register would be 45016.

**Table B-16 Alarm Threshold Registers**

Register	Data Type	Description
45009	unsigned int	Threshold for Particle Channel 1 [high] (smallest particle size starts here)
45010	unsigned int	Threshold for Particle Channel 1 [low]
45011	unsigned int	Threshold for Particle Channel 2 [high]
45012	unsigned int	Threshold for Particle Channel 2 [low]
45013	unsigned int	Threshold for Particle Channel 3 [high]
45014	unsigned int	Threshold for Particle Channel 3 [low]
45015	unsigned int	Threshold for Particle Channel 4 [high]
45016	unsigned int	Threshold for Particle Channel 4 [low]
45017	unsigned int	Threshold for Particle Channel 5 [high]
45018	unsigned int	Threshold for Particle Channel 5 [low]
45019	unsigned int	Threshold for Particle Channel 6 [high]
45020	unsigned int	Threshold for Particle Channel 6 [low]
45021	unsigned int	Threshold for Particle Channel 7 [high]
45022	unsigned int	Threshold for Particle Channel 7 [low]



**Table B-16 Alarm Threshold Registers**

<b>Register</b>	<b>Data Type</b>	<b>Description</b>
45023	unsigned int	Threshold for Particle Channel 8 [high]
45024	unsigned int	Threshold for Particle Channel 8 [low]

**Setting the Alarm Threshold Value**

The Alarm Threshold Value is set in the low register of the channels.

**Table B-17 Alarm Threshold Registers set to default value**

<b>Registers</b>	<b>Particle Channel</b>	<b>Threshold Value</b>
45009 - 45010	1	1000
45011 - 45012	2	1000
45013 - 45014	3	1000
45015 - 45016	4	1000
45017 - 45018	5	1000
45019 - 45020	6	1000
45021 - 45022	7	1000
45023 - 45024	8	1000



# Index

## Numerics

30076  
Alarm Flags B-11

## A

Additional help 1-i  
Alarm Enable Registers B-13  
Alarm Flags B-11  
Alarm Registers  
    Enable Alarming B-15  
Automatic Mode 4-2

## B

big-endian data B-8

## C

Command Register B-6  
Communication Modes 2-2  
Communications 4-1  
Communications Settings B-1  
Configure the RAC System 4-1  
Controller Ports 3-4

## D

Data Registers B-8  
    Device Status Word B-10  
Data Type Registers B-11  
Data Units Registers B-12  
DDP Switch 3-3  
Device Status B-6  
Device Status Word B-10  
Dimensions 2-2

## E

Enable Alarming B-15  
Enclosure 2-2

## G

General Safety 1-1

## H

Help 1-i

## I

Installation 3-3  
Instrument Start 4-2  
Instrument Stop 4-2

## L

LED Indicators 2-2  
Limitation Of Warranties A-1  
Limited Warranty A-1  
little-endian data B-8  
LMS Express 7 3-9

## O

Overview 2-1

## P

Power 2-2

## **R**

RAC Controller 3-3  
Read RAC System Information 4-2  
Register Map B-2  
Remote Mode 4-2  
Remote Switch 3-3  
RJ-45 Pinouts 3-7  
Running the RAC System 4-2

## **S**

Safety Considerations 1-1  
Save configuration to instrument's EEPROM  
    4-2  
Sensor Settings Registers B-2  
Setting the Alarm Threshold Value B-17  
Setup Instrument Driver 3-11  
Specifications  
    RAC System 2-2  
Supported MODBUS Commands B-1  
Supporting Software 2-2

## **T**

Technical Assistance 1-1  
Text conventions 1-i  
Threshold Setup Registers B-16  
    Setting the Alarm Threshold Value B-17

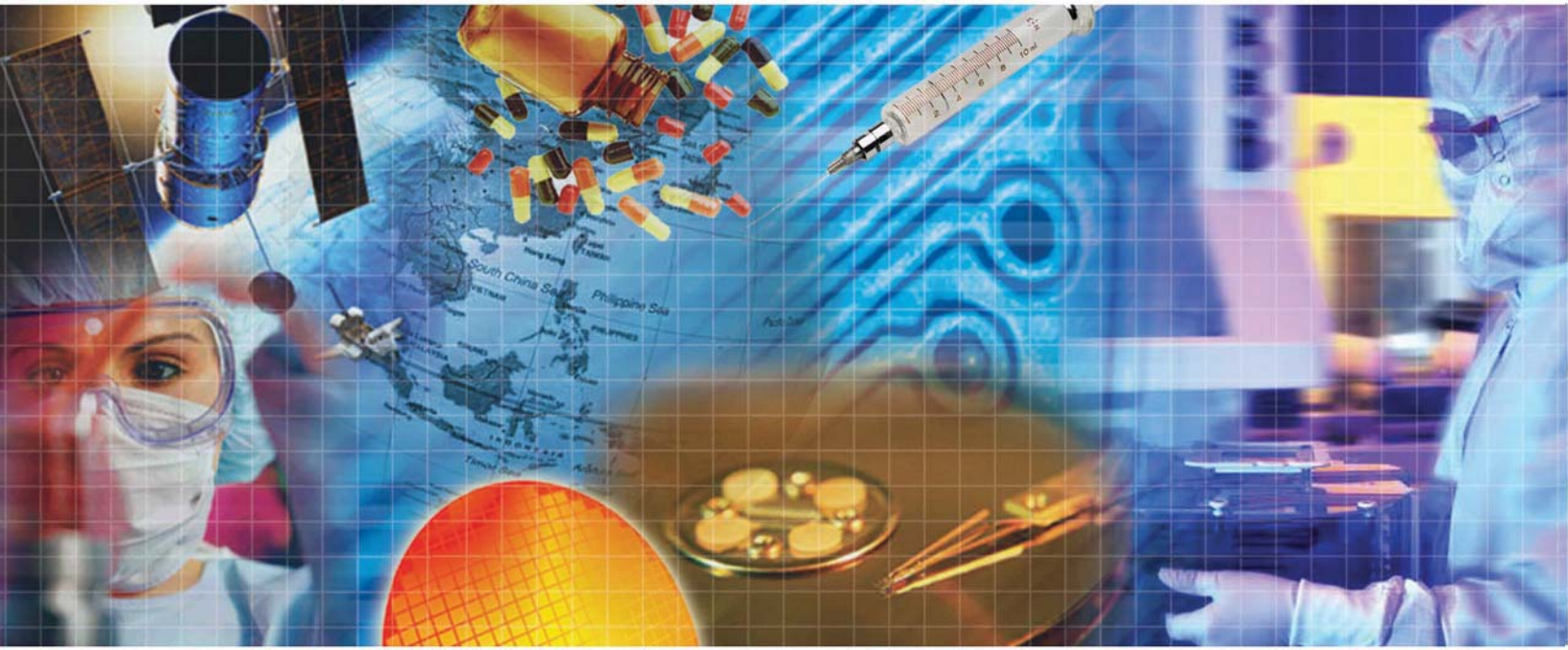
## **V**

Vacuum Requirement 2-2  
Valid Data B-10

## **W**

Warranty A-1  
Weight 2-2





**Service and Support**  
**Tel: 1-800-945-5905 (USA Toll Free)**  
**Tel: 1-541-770-5905 (Outside of USA)**  
**[techsupport@golighthouse.com](mailto:techsupport@golighthouse.com)**  
**[www.golighthouse.com](http://www.golighthouse.com)**