

# Haier



## Combined Refrigerator and Freezer Operation Manual

Model:  
HYCD-282  
HYCD-282A

Certificate of Quality

checker:



Manufacturer: Qingdao Haier Biomedical Co., Ltd.  
Address: Haier Industrial Park, Economic Technology Development  
Zone. Qingdao P.R.China

Web: [www.haiermedical.com](http://www.haiermedical.com)

Revision Date: 09/2018

Version: 1st, 2018

Dedicated code: 0270501012

V13026

- Read the Operation Manual carefully before using your appliance.
- Keep the Operation Manual in a safe place.
- Appearance, color and layout of the door may vary.
- Translation of the original instruction.
- The scope of the product application: The upper scope is fit for pharmaceuticals and other related products which needs a storage environment of 2~8 °C. The lower scope is fit for low temperature storing goods.

EC Declaration of Conformity

according to the Machinery Directive 2006/42/EC

For the following equipment :

Product : Combined Refrigerator and Freezer

Type Designation/Trademark: HYCD-282 | Haier  
HYCD-282A

Manufactures Name : Qingdao Haier Biomedical Co., Ltd.

Manufactures Address : Haier Industrial Park, Economic Technology  
Development Zone. Qingdao P.R.China

Refer to in this declaration confirms with the following directive(s)/standards:

2006/42/EC, EN60335-1, EN60335-2-89 EN62233

Global Warming Potential

Model	Rated voltage ( VAC )	Rated frequency ( Hz )	CO <sub>2</sub> equivalent (Tonnes)
HYCD-282	220~240	50	0.707
HYCD-282A	220~240	50	0.707
HYCD-282A	220~240	60	0.920

This product contains fluorinated greenhouse gases covered by the Kyoto Protocol. Do not vent into the atmosphere.

GWP=global warming potential

Refrigerant type	GWP
R134a	1430
R600a	20
R404A	3922

Haier quality, it merits your trust from beginning to end.

This product is mainly used for storage of cryopreserved blood plasma, biological material, vaccine and low temperature test of video, electronic device and special materials. It is suitable for blood station, hospital, quarantine station, universities, research institute, electronic chemical and other enterprise labs.

- Temperature control**
  - Computer controlled, digital display of temperature, the temperature of refrigerating chamber on computer display board is adjustable in 0~16°C. The temperature of freezing chamber is adjustable in -10~-45°C, the normal service range of refrigerating chamber is 2~8°C, and that of freezing chamber is -20~-40°C.
- Safety system**
  - Multi-fault alarm (High and low temperature alarm, power failure alarm, sensor fault alarm, door opening alarm, circumstance temperature alarm, low battery alarm)
  - Two alarm ways (Buzzer sound alarm, alarm indicator lights flashing for alarm)
  - All independent components are safely grounded
- Refrigeration system**
  - Deeply optimized refrigeration system, famous brand compressor and main components have better refrigeration performance
  - Refrigerating chamber and freezing chamber have independent refrigeration control, the temperature in box is mutual independent
- User-friendly design**
  - Humanized design, computer controlled, and be intelligent without adjustment .
  - High performance insulating layer with good insulation effect .
  - Automatic evaporation of condensate water, safety door latch and other humanized design
  - Refrigerating chamber and freezing chamber have independent refrigeration control, they can be used individually as needed.

I hereby apologize for the inconformity of your Haier pharmaceutical refrigerator with freezer with manual figure due to product improvement. Manual content will change without prior notice.

**Content:**

Product Feature.....1  
Content.....2  
Safety Precautions.....3  
Precautions for Use.....6  
Product Installation .....7  
Component Names • Control Panel.....11  
Application method .....14  
Alarm.....17  
Cleaning and Maintenance.....20  
Rechargeable Battery Recycling.....22  
FAQ.....23  
Refrigeration Schematic & Circuit Diagram.....24  
Specification.....26

**Packing List**

Name	HYCD-282	HYCD-282A
Manual	1	1
Defrost shovel	1	1
Plastic bag	1	1
Support	2	2
Infinite partition board	4	4

Specification

Name	Combined Refrigerator and Freezer	
Model	HYCD-282	HYCD-282A
External dimensions (WxDxH) (mm)	735×660×1810	
Internal dimensions (WxDxH) (mm)	Refrigerating chamber: 605x510x720 Freezing chamber: 515x465x440	
Effective volume	Refrigerating chamber: 185L Freezing chamber: 97L	
Door	Foaming door	Glass door
Insulating material	Rigid polyurethane foams (Fluoride-Free)	
Compressor	Fully enclosed famous brand compressor	
Shelf/drawer	Refrigerating chamber: 3 /1 Freezing chamber: 0/2	
The loading of each shelf	Max:12kg	
Cooling method	Refrigerating chamber: Forced air cooling circulation Freezing chamber: Direct-cooling	
Outside plate/Inside plate	Spraying steel plates/stainless steel plate	
Condenser/Evaporator	Wire and tube type/bare tube type	
Temperature controller	Computer control system	
Refrigerating fluid	Refrigerating chamber: R600a 50g Freezing chamber: R404a 180g	
Refrigerating chamber lamp	LED 1.5W	LED 1.5W
Net weight	145g	
Temperature	Refrigerating chamber: 2°C~8°C Freezing chamber: -20°C~-40°C	
Rated power supply	220-240V~/50Hz	220-240V~/50Hz
Rated power/current	400W/2.8A	400W/2.8A
Noise Level	45dB(A)	45dB(A)
Foaming Agent	CP/IP	CP/IP
Climate Type	4	4
Electric shock resistance type	I	
Power connect style	Y	
Alarm equipment	High and low temperature alarm, sensor failure alarm, power failure alarm, door opening alarm, environment temperature alarm, low battery alarm	

Power outage alarm duration 48h (When battery is fully charged)

Note: Climate Type 4 means the temperature is +30°C, the relative humidity is 55%. Technical information may vary from the appliance that you have just purchased due to technical improvements.

Dear users:

Thanks for your choice of Haier Combined Refrigerator and Freezer; please make sure you have carefully read and observed the contents with following signs in the manual, for better understanding of this manual and better use of this product, to prevent personal injuries and goods damage.

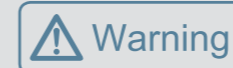

Warning

Ignoring this warning may result in death or serious injury



Actions or operations which are prohibited



Caution

Ignoring this warning may result in death or serious injury, and/or damage to the refrigerator and property



Actions or operations which must be followed



Warning

- ❗ In case of flammable gas leakage such as coal gas, the valve leaking gas should be closed, open doors and windows for ventilation exhaust, don't plug in or out the power plug of refrigerator-freezer, or it may cause explosion and fire.
- ❗ Only professional technicians or after-sale maintenance personnel can install refrigerator-freezer. Or it may cause electric shock or fire.
- ❗ Make sure to put the refrigerator-freezer on firm and flat ground surface stably. If the ground is not firm or not properly placed, refrigerator-freezer may turn over or cause personnel injury.
- ❗ Please use the special power supply marked on equipment nameplate, or it may cause fire or electric shock.
- ❗ If the service voltage is lower than 198V or higher than 242V, automatic voltage regulator of over 400W suitable for motor load should be added.
- ❗ If the power wire should be lengthened, the sectional area of extension cord should not be less than 2mm<sup>2</sup>, and not be longer than 3m. Or it may cause fire or electric shock.
- ❗ Power line of refrigerator-freezer has three wire plug (Grounded), and standard three wire socket (Grounded) meeting 16A. Never cut off or remove the earthing pin of power line. Make sure the power plug and socket are stuck tightly, firm and reliable, or it may fire.
- ❗ Please use the power socket connecting ground wire to avoid electric shock. If the power socket is not grounded, be sure to install the ground wire by professional technician.
- ⊘ Don't use refrigerator-freezer outdoor. When the equipment is drenched by rain, it may cause electric leakage or electric shock.
- ⊘ Don't place refrigerator-freezer in damp environment or place easy to suffer spray water. Or it may cause electric leakage or electric shock due to insulation level reduction.
- ⊘ Don't pour water directly on refrigerator-freezer, or it may cause electric shock or short circuit.

- ⊘ Don't put container with water or heavy stuff on refrigerator-freezer. Or the object may fall to injury person, and the water will reduce insulation level to cause electric leakage or electric shock.
- ⊘ Refrigerator-freezer should not be grounded through gas pipe, power supply tube, telephone line or lightning rod. Above earthing may cause electric shock or other danger.
- ⊘ Don't contact any electric parts as power socket and switch with wet hand, or it may cause electric shock.
- ⚠ When plugging out power socket, hold the power plug firmly and not pull lead of power plug. Pulling lead by hand may cause electric shock or fire due to short circuit.
- ⚠ If the operation of refrigerator-freezer is not normal, please plug out power plug. Continue operation under abnormal status may cause electric shock or fire.
- ⊘ User should not dismantle, repair or modify refrigerator-freezer. Or it may cause fire or personnel injury due to improper operation.
- ⚠ Make sure to disconnect refrigerator-freezer power before any repair or maintenance of refrigerator-freezer, or it may cause electric shock or personnel injury.
- ⚠ Be sure not to breathe in dust or suspended particles in and around refrigerator-freezer during repair and maintenance, or it may affect health.
- ⚠ Please use refrigerator-freezer in safe area when storing poisonous, harmful or radioactive materials. Improper use may bring harm to human health or environment.
- ⚠ Pull out the power plug if the freezer has been out of service for long time to prevent electric shock, leakage or fire caused by aging power lines.
- ⚠ If refrigerator-freezer is not used for long time in area without monitoring, please make sure children will not be close to refrigerator-freezer, and the door should not be closed fully.
- ⚠ The end-of-life disposal of refrigerator-freezer should be done by corresponding person. Door should be dismantled, or it may cause accident as asphyxia.
- ⊘ Don't light inflammable, explosive hazardous articles or volatile materials in refrigerator-freezer, nor use flammability spray nearby, or it may cause explosion or fire.
- ⊘ Don't touch acid, alkali and other corrosives. Or it may damage the internal components or electrical parts of refrigerator-freezer.
- ⊘ The plastic package bag should not be put in an easily accessible place for children, or it may cause asphyxia accident.
- ⊘ Don't climb on refrigerator-freezer or put objects on it, or refrigerator-freezer may turn over and cause personnel injury or refrigerator-freezer damage.
- ⊘ Don't insert metal objects as iron nail or iron wire into any hole, gap or any exhaust port of refrigerator-freezer or internal air circulation, or the above objects may contact with moving parts to cause electric shock or injury.

### Circuit Diagram

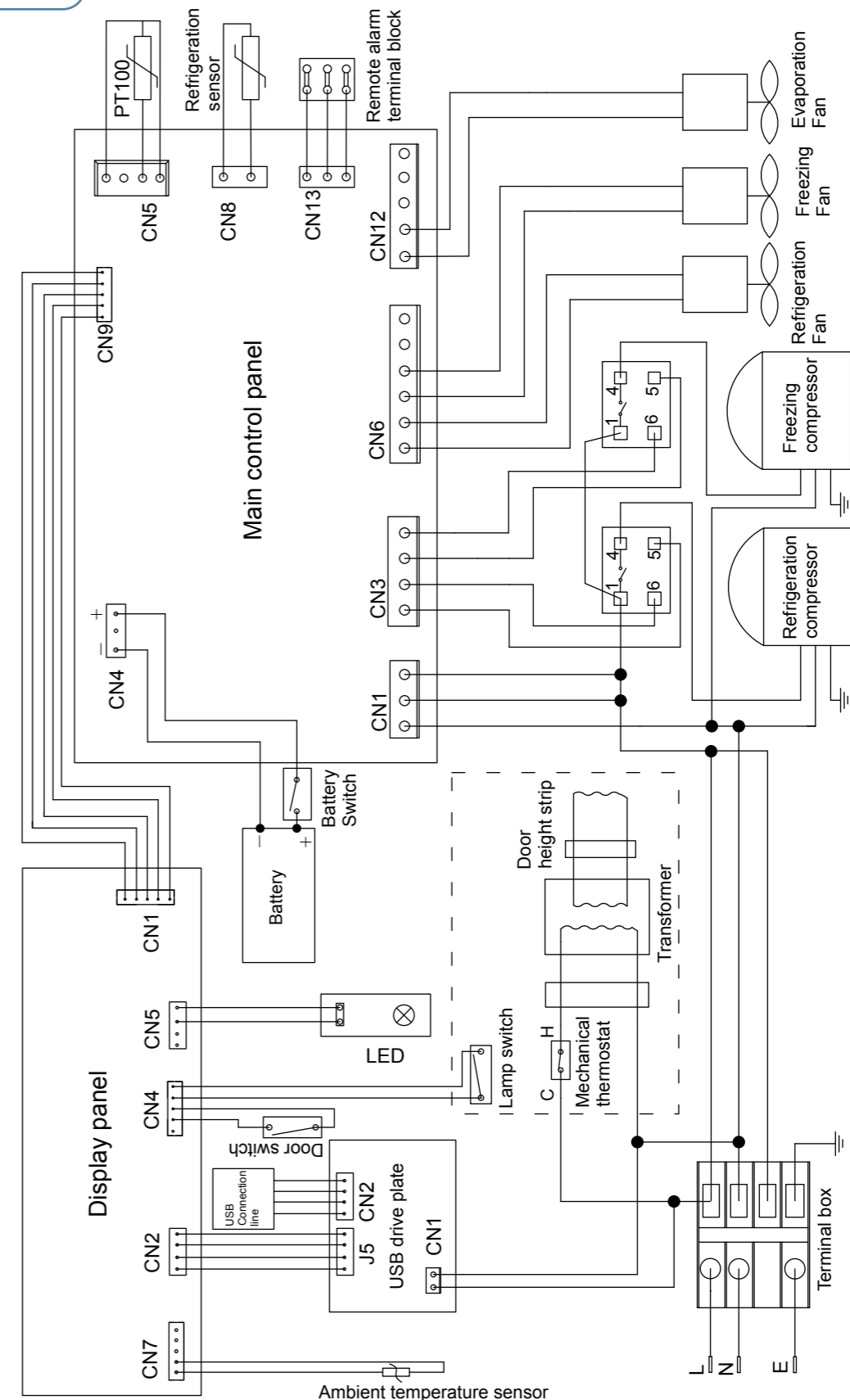

Note: The content in the frame with dotted lines are applicable for HYCD-282A series.

Refrigeration schematic diagram (refrigeration)

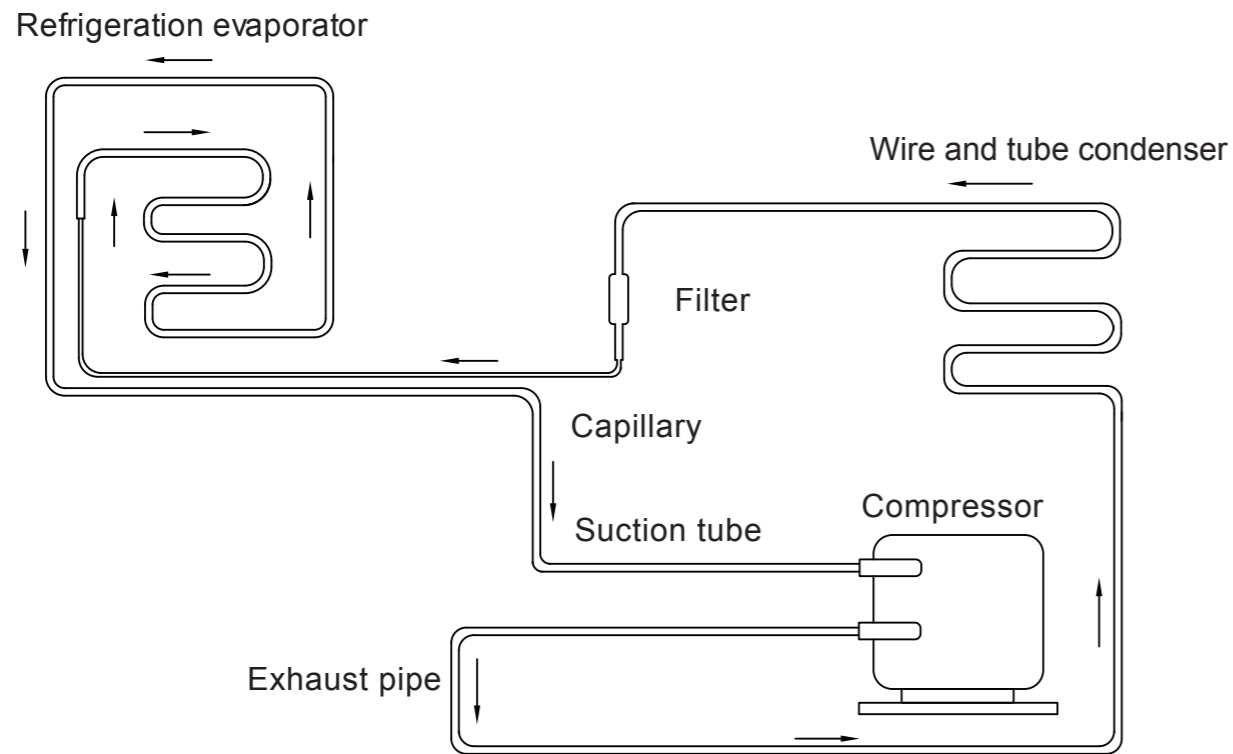

Refrigeration schematic diagram (frozen)

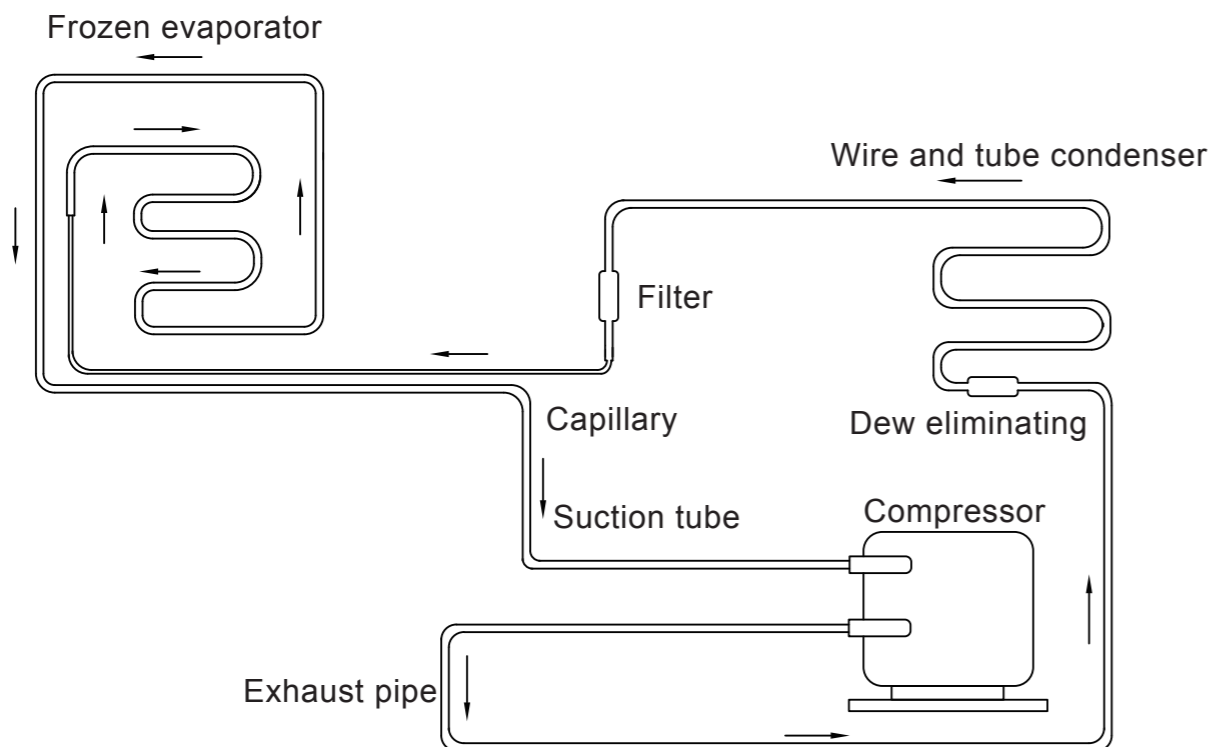

## ⚠ Caution

- ⚠ It needs to examine the setting of refrigerator-freezer when restart it after outage or power off. The change of setting may damage the stored articles.
- ⚠ Once the power of refrigerator-freezer is cut off, it needs to wait for 5min before reconnection, or compressor or system may be damaged.
- ⚠ Please wear gloves for maintenance, or it may cause personnel injury by contacting sharp edge or corner.
- ⚠ Close door by holding handle, or door may clamp finger.
- ⚠ When moving refrigerator-freezer, the inclination angle should not be bigger than 45°.
- ⚠ Be careful to move refrigerator-freezer, and not fall over, or it may cause equipment damage or personnel injury.
- ⚠ Don't move equipment by lifting or pulling handle, or it may cause refrigerator-freezer damage or personnel injury.
- ⚠ There should be no obstacles around refrigerator-freezer, keep good ventilation.
- ⚠ Don't damage refrigerating circuit.
- ⚠ Do not use electrical appliances inside the food storage compartments of the appliance, unless they are of the type recommended by the manufacturer.
- ⚠ The appliance must be positioned so that the plug is accessible.
- ⚠ The appliance must be placed on a solid and flat surface, or excessive vibration and noise may be produced when the appliance in operation.
- ⚠ The appliance can be used by children aged from 8 years and above and persons with reduced physical, sensory or mental capabilities or lack of experience and knowledge if they have been given supervision or instruction concerning use of the appliance in a safe way and understand the hazards involved. Children shall not play with the appliance. Cleaning and user maintenance shall not be made by children without supervision.
- ⚠ If the supply cord is damaged, it must be replaced by the manufacturer, its service agent or similarly qualified persons in order to avoid a hazard.
- ⚠ Keep ventilation openings, in the appliance enclosure or in the built-in structure, clear of obstruction.
- ⚠ If your cabinet is to be discard, you must remove the door and leave the shelves in place. This will reduce the possibility of danger to children. And the flammable foaming needs to be disposed by professional persons.
- ⚠ CP/IP foaming materials are flammable, need professional processing.

- If the refrigerator-freezer is started for first time or not used for a long time, the battery may be low when testing, this is normal because the rechargeable battery is completely discharged. In such situation, switch on battery, and the battery will be fully charged after 6 days of continuous operation of refrigerator-freezer.
- To prevent condensation around freezing chamber cabinet, dew removable tube is installed, when refrigerator-freezer runs, there may be hot around door frame of freezing chamber cabinet, this is normal.
- Confirm whether the internal temperature is fully reduced before putting things in refrigerator, then put things in batches when it reaches required temperature, or the temperature may rise.
- The temperature display value of this product refers to that of heat detector inside, and there is certain deviation for displayed temperature and the actual temperature at center of refrigerator, but it will gradually be close to true temperature.
- Two through holes are installed on side wall of this product to bring the measuring line in refrigerator, and make sure to plug the measuring hole by thermal insulation material after measurement, or the temperature in refrigerator will not fully reduce.
- Clean equipment by diluted mild detergent (Undiluted detergent may damage plastic compositions, please refer to detergent instruction for dilution method. Don't use brush, acid, and gasoline, soap powder, polishing powder or hot water to clean refrigerator, or it may damage paint surface and plastic, rubber parts, and pay extra attention not to use volatile solvent as gasoline to wipe plastic and rubber parts.
- After running a period of time, the inner wall of refrigerator-freezer will form a layer of frost, too thick frost will influence refrigeration effect, increase power consumption, so when the frost layer is 5mm at certain interval, use attached shovel or “” key on control panel to defrost.
- Please take things out of refrigerator-freezer before defrosting, and store in another refrigerator-freezer, or the temperature inside may rise and damage things.
- There are many cooling coils on inner container, and don't defrost the inner container by knife, ice chisel or screwdriver and other sharp edge tool. Pay attention not to scratch evaporation tube, or it may cause equipment fault.
- For refrigerator-freezer not used for a long time, cut off the power supply, and turn off battery switch.



Meaning of crossed –out wheeled dustbin:

Do not dispose of electrical appliances as unsorted municipal waste, use separate collection facilities. Contact you local government for information regarding the collection systems available. If electrical appliances are disposed of in landfills or dumps, hazardous substances can leak into the groundwater and get into the food chain, damaging your health and well-being. When replacing old appliances with new ones, the retailer is legally obligated to take back your old appliance for disposals at least free of charge.



Any questions for use? Doubt the refrigerator-freezer failure? Please look here. This chapter will give answers to various possible failures, and solutions. If the problem is still not solved after operation, please call Haier after-sales service.

Please never repair and dismantle refrigerator-freezer.

Failure	Troubleshooting plan
Refrigerator-freezer is off	Check whether the input power meets requirement
	Whether the plug and socket are well contact
	Whether there is input and control wire failure
	Whether the voltage is too low
Cooling effect is not obvious, temperature exceeds standard	Whether there are too many or too hot articles
	Whether there is certain gap among stored articles
	Whether there is direct sunlight or other hot source radiation
	Whether the door is opened too frequent
	Whether the environment temperature is too high
Excessive noise	Whether the air duct is blocked (Only applicable to refrigerating chamber)
	Whether the refrigerator-freezer is stably placed
	Whether part of cabinet contacts outer goods or wall
Alarm lamp flashes, buzzer alarm	The noise marked in technical data is in the standard library without noise, put the empty refrigerator-freezer on rubber gasket, run stably after closing door, but not include startup, shutdown, and the average data measured 1m away from surface. It is normal for difference of actual noise and marked value, because there is influence of loading goods, environment noise, not close door, startup and shutdown of compressor.
	Whether the goods are put in just now, and the temperature is not stable, and the alarm will disappear automatically after cooling for a period of time
	Whether the door is not fully closed, and it is door open alarm lamp
	Whether the power supply is insufficient, and it will recover to normal after starting for a period of time
	Whether the temperature exceeds standard



Install a recyclable charging battery in refrigerator-freezer, and when it is to achieve the service life, please contact local battery recycle agent for inspection, or correctly discard the battery.

## Position of battery

The battery in refrigerator-freezer is for power outage alarm, and it is in electric cabinet.

- ! Electric cabinet has high voltage electrical apparatus element. To prevent electric shock, the cover should be opened by professional engineer or maintenance man.

## Take out the battery

1. Unplug power plug from socket;
2. Remove the screws from electric cabinet cover by screw driver;
3. Unplug the connection plug of battery;
4. Dismantle the fixed clamp of battery, and take out battery;
5. Recycle or correctly dispose battery as required.

- ⊘ When replacing battery, make sure the brown wire is connected to battery anode, blue wire is connected to battery cathode. Or it is easy to burn the charging circuit of computer board, which will not be able to charge battery.

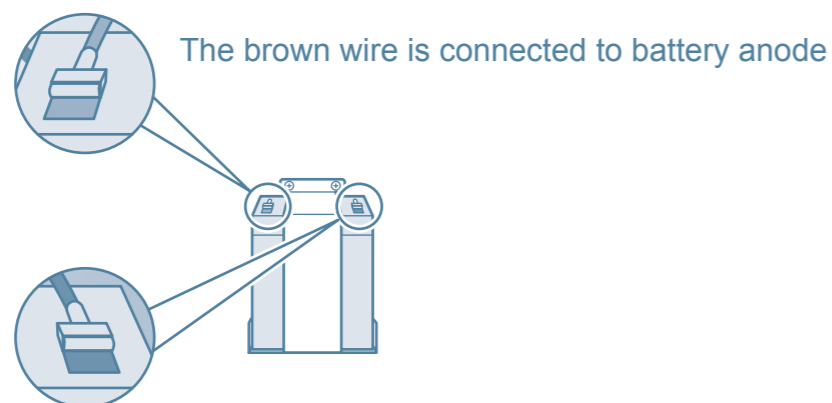

The blue wire is connected to battery cathode

## Installation environment

- Environment temperature: 16°C to 32°C, the ideal temperature is 18°C to 25°C, and air conditioning system should be used when necessary.
- Environment humidity: Lower than 75%Rh.
- To avoid a great deal of dust.
- To avoid mechanical swing or vibration.
- The altitude of working position of refrigerator-freezer: Lower than 2,000m.
- Input voltage: Within 220V ± 10%.

### ⚠ Caution

- Refrigerator-freezer is sensitive to environment temperature. Refrigerator-freezer can't work normally if it is installed in other environment. Please use after environment improvement.
- It is not allowed to install refrigerator-freezer outdoor. When the refrigerator-freezer is drenched by rain, it may cause electric leakage or electric shock.

## Installation site

To enable the refrigerator-freezer to work normally and obtain best performance, the installation site of refrigerator-freezer should meet the following conditions:

- It can't be installed in small airtight space, and the door of room for placement should not be smaller or lower than this product, it should at least allow normal in and out of product, or it may be hard to repair fault machine, nor timely recover machine and cause stored goods damage.
- Installation ground must be firm and flat.
- Good ventilation, avoid direct sunshine.
- Don't share socket with other equipment plug, plug and socket should be firmly connected.
- Don't bend or press power wire.
- If the power wire should be lengthened, the sectional area of extension cord should not be less than 3mm<sup>2</sup>, and not be longer than 3m.
- Inspect the working voltage before use, voltage regulator with proper motor load should be considered in area with unstable voltage. To enable the normal input voltage as 220V ± 10%, the power of voltage regulator should be greater than 400W.
- Refrigerator-freezer should be reliably earthed.
- If power socket has ground wire, check whether it is well earthed before use.
- If the power socket doesn't have ground wire, be sure to install the ground wire by professional technician.

### ⚠ Warning

- Refrigerator-freezer should not be grounded through gas pipe, water supply tube, telephone line or lightning rod, or it may cause electric shock.
- The power plug must be accessible after installation, so that it can be unplugged in emergency. Nothing can block the ventilation opening of refrigerator-freezer.

## Preparation before use

### 1. Remove the packing material and packaging tape

Remove the all packing materials and packaging tapes for transportation.

#### Caution

- Use fork truck or clip package car to move refrigerator-freezer before unwrapping. If fork truck is used to move refrigerator-freezer, it should be inserted at bottom of wooden base from front or back. If clip package car is used, it can only clip from bottom of wooden base at side face.
- Trundle can be used to move the cabinet after removing package.
- The inclination angle of cabinet should not be greater than 45° during moving.

### 2. Check out standard attachments

Please check out the articles in cabinet according to packing list, if there is any discrepancy, please contact with after-sales service department.

### 3. Placing conditions

Leave at least 30cm gap around refrigerator-freezer for ventilation and heat dispersion.

Take our two metal foot in shape of “几”, and four attached screws from cabinet drawer, fix the foot in holes at back board outside cabinet, so as to avoid contacting with wall directly.

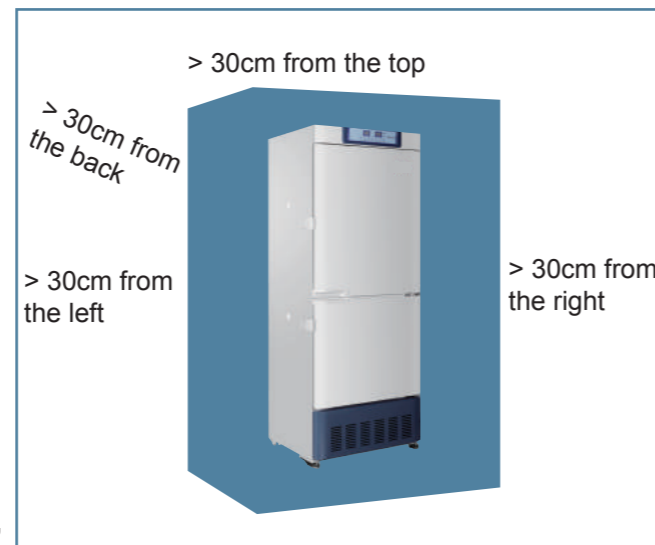

### 4. Adjust bracing foot

Bracing foot has been adjusted to proper height before delivery, if it is needed, rotate level supporting foot in clockwise by wrench to enable it stretch out, and support on ground, make sure the balance and stability of refrigerator-freezer.

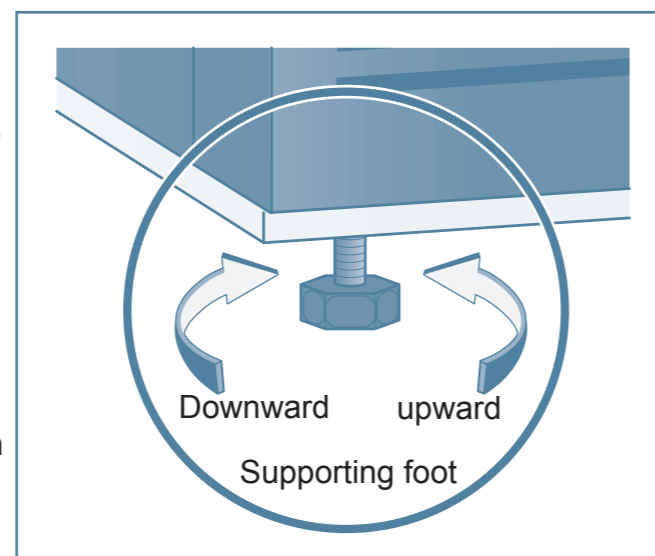

### 5. Standing

After placing and leveling, cleaning machine body, don't power on. Stand for more than 24h before power on, and make sure the normal operation of refrigerator-freezer.

## Battery maintenance

1. For continuous power on of equipment, please inspect battery power every 15 days (See P17 for inspection method, alarm test function), in case of low battery, make sure the battery switch is turned on, then the battery will be charged, after continuous charging for a week, please retest battery power, which should be full in normal condition, if it is still low battery, the charging battery should be replaced.
2. Power outage alarm battery is consumable, and battery life is about 3 years, if it is used for over 3 years, it may fail to act in case of alarm, battery should be replaced earlier, and please contacts Haier after-sales servicer.

## Stop refrigerator-freezer

- If refrigerator-freezer needs to stop working for a long time, you should cut off power and turn the power switch to “O”;
- Open refrigerator-freezer door, and take the inner shelf out;
- Completely clear the refrigerator-freezer;
- Clear the shelf;
- When the refrigerator-freezer and shelf are dry, put shelf back into refrigerator-freezer;
- Close the cabinet door, and put a plastic bag for sealing.

#### Warning

If equipment is not used for long time in area without monitoring, please make sure children will not be close to the equipment, and the door should not be closed fully, the end-of-life disposal of equipment should be done by corresponding person, to prevent asphyxia accident, make sure to dismantle the cabinet door .

## Component Cleaning



### Warning

- To prevent electric shock or personnel injury, make sure to cut off refrigerator-freezer power before any repair.
- Be sure not to breath in drug or suspended particle around refrigerator-freezer during maintenance, or it may affect your health.

### Cleaning

- Refrigerator-freezer should be cleaned once a month. Regular cleaning to make refrigerator-freezer to keep brand new appearance.
- Wipe the dust on refrigerator-freezer shell, inner room and all attachments by dry cloth. If the refrigerator-freezer is very dirt, clean it by cleaning cloth soaked in neutral detergent, and wipe the residual detergent by wet cloth, then dry cloth.
- Don't pour water on refrigerator-freezer shell or interior, or it may damage appliance insulation and cause failure.
- Compressor and other mechanical parts are in completely seal status without lubrication.

### Inner wall defrosting

The frost is generally close to door seal in cabinet, and frost may result in gap between cabinet and door seal, causing bad cooling effect, use attached shovel to defrost, the following steps are for defrosting by moving empty cabinet.

- Take out the cabinet articles to other equipment;
- Turn off power switch;
- Open cabinet door for a period of time to defrost;
- Dry the water at bottom of cabinet by a dry cloth;
- Restart equipment after cleaning cabinet body;
- Put articles back when the cabinet is fully cooled.

If only freezing chamber needs to defrost, you can press defrost key on display board, the operation method is, long press defrost key for 5s after unlocking keyboard, the refrigeration system of freezing chamber will stop working. After defrosting, manually press defrost key for 5s again to deactivate defrost mode, the refrigeration system of freezing chamber will restart.



### Caution

Don't use knife, screw driver and other shape edged tools to defrost.

## Initial Power-on

Observe the rules below for initial start-up and continuous operation:

Under the condition of empty cabinet, connect power wire to special socket with proper specification, and make sure the power supply is 220V/50HZ .



Turn on the charging battery switch of machinery electric cabinet on top of refrigerator-freezer back (It can be seen from back of refrigerator-freezer), if it is not turned on, there will be low battery alarm during test, and press buzzer cancel button can clear the alarm.



Set the required temperature: Keep the cabinet empty, boot with electrify, and observe normal on-off of refrigerator-freezer for over 24h, certifying the normal performance.



After a period of running, the temperature of refrigerator-freezer will be stable at setting value.



When the operation of refrigerator-freezer is completely checked, gradually put articles in cabinet.



- This product is responsible by special person, who will check the operation and record every day (Record and check every 2-4h), the temperature in cabinet will rise in case of machine fault or stop, if it can't be repaired in short time, please take out articles and move to the places meeting storage temperature requirement, and avoid damage.
- Before putting goods in this product for storage, confirm in advance that the temperature for stored goods meets the temperature range of this product, for fear that the temperature of this product can't reach the required temperature of stored goods and cause goods damage, resulting in lose.
- The actual display temperature has certain difference with setting temperature due to refrigeration inertia (The lower the setting temperature of freezing chamber, the smaller the temperature difference, and the greater the versa), this is normal.



- It is not allowed to put too many things one time, or it may cause compressor non-stop for a long time, temperature falls slowly and will influence compressor life, goods should be stored in batch, and temperature will fall ladderlike until the required temperature.
- Don't damage refrigerating circuit.
- use electrical appliance without the consent of the production in refrigerator-freezer.

## Operation after Outage

Refrigerator-freezer has memory function for setting value, when it is power on after power failure, refrigerator-freezer will continue running with the set parameters before last power failure.



- Once the power of refrigerator-freezer is cut off, it needs to wait for 5min before reconnection, or compressor or system may be damaged.
- Please unplug power plug when the refrigerator-freezer is not used for a long time, and turn the batter switch to "O", or it may cause electric shock, electric leakage or fire due to aging power wire.
- If refrigerator-freezer is not used for long time in area without monitoring, please make sure children will not be close to the refrigerator-freezer, and the door should not be closed fully.

### Automatic recovery of alarm

This series of refrigerator has alarm automatic recovery function:

- In case of alarm, press the buzzer cancel key on display board to stop buzzer alarm. (Remote alarm will not stop)
- If there is still alarm condition, buzzer alarm will automatically recover after stopping 30min.

### Remote alarm terminal

- Remote alarm terminal are loacted in top electric cabinet at the back of refrigerator-freezer. Alarm signal output is carried out by these terminals with carrying capacity of DC 30V/2A.
- Contact output:  
In normal conditions, both ends of remote alarm terminals with connecting wire form open circuit. In alarm conditons, both ends of remote alarm terminals with connecting wire form cloase circuit. To use remote lalarm function, connect circuit as shown in the figure below.



Remote alarm function is limited to three alarm modes, i.e. high temperature alarm, low temperature alarm and power failure alarm.

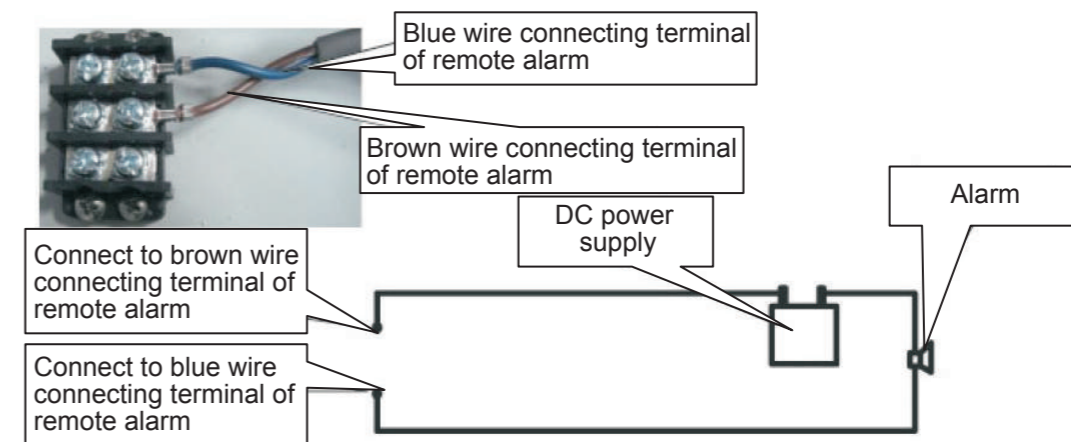

Alarm	Phenomenon	Fault code	Indication	Buzzer alarm
High temperature	When the cabinet temperature is higher than the setting value of high temperature alarm	E9	Indicator will flash	It is set by default that buzzer alarm will start 2h after first boot, for normal operation, buzzer alarm will delay 15min
Low temperature	When the cabinet temperature is lower than the setting value of low temperature alarm	E10	Indicator will flash	
Power failure	Power failure of refrigerator-freezer	/	Alarm indicator flashes, the blank screen of display screen and actual cabinet temperature display alternately	Buzzer alarm delays 30s
Environment temperature is high	Environment temperature is higher than 38°C	E14	Indicator will flash	-----
Sensors abnormal	Main sensor failure in refrigerator-freezer	E6	Indicator will flash	Buzzer alarm
	Main sensor failure in refrigerator	E3	Indicator will flash	Buzzer alarm
	Environment temperature sensor failure	E0	Indicator will flash	-----
Low battery	Battery power shortage or battery switch not open	E5	Indicator lights on	-----
Door opening alarm	Refrigerating chamber door is opened or not closed well for over 15min	/	Indicator will flash	Buzzer alarm

Component Names

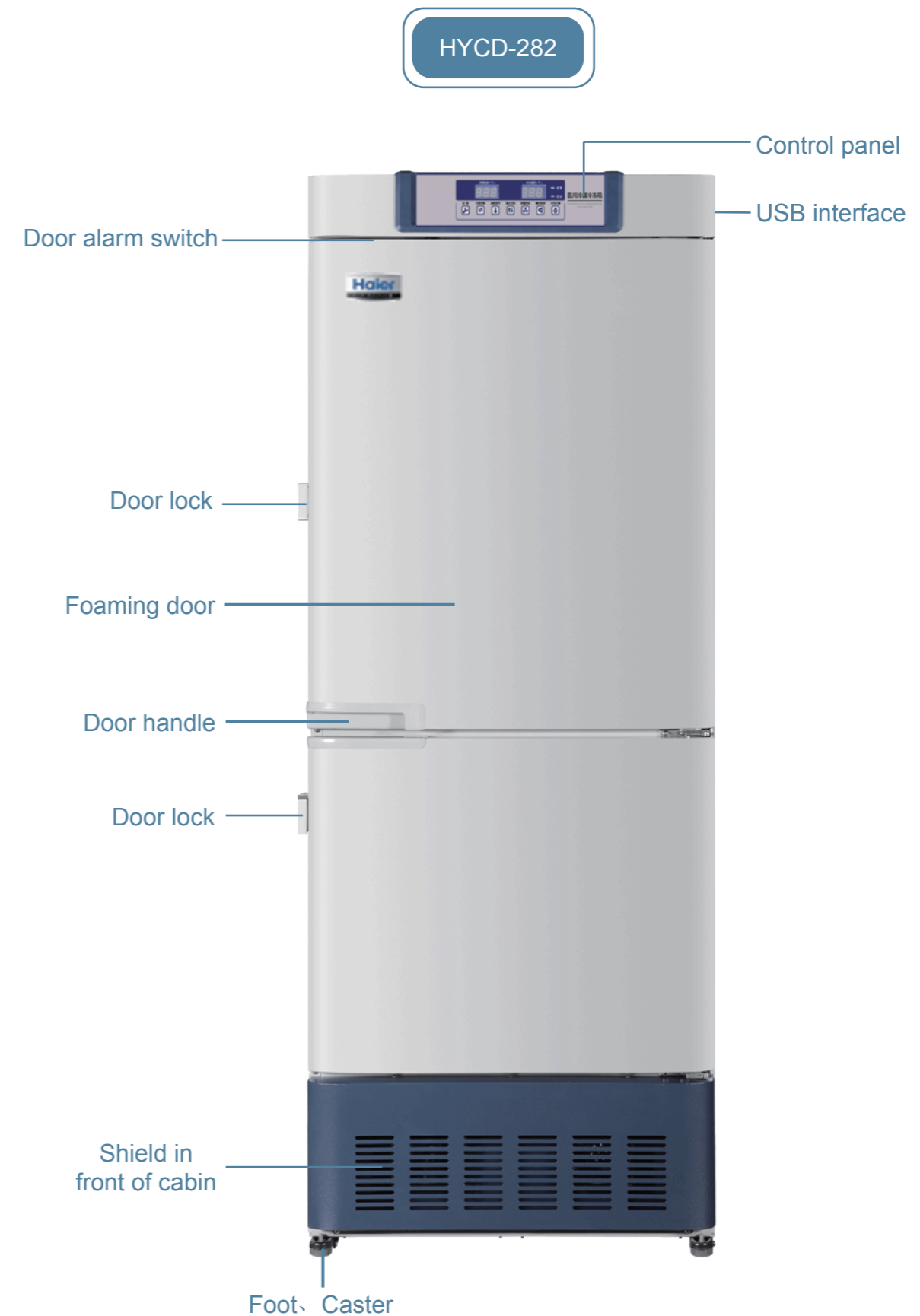



After power on, refrigerator-freezer will enter into start status, display screen will show cabinet temperature.

Display panel work status hints:

- Lock Indicator: Light on means all settings are locked to prevent misoperation.
- Alarm indicator lamp: Light on or flashing means failure.

Key function:

- Cancel buzzer: In lock or unlock status, press “

**Caution**

In case of multiple alarms, each alarm failure code will display for 3s respectively. Battery switch should be opened before normal boot, once the AC power meeting equipment requirement is connected, equipment will enter into normal work status. Equipment can charge battery for normal power supply of AC. In case there is accidental AC power outage, battery will supply power to display screen to enable normal display. When battery discharges with voltage be lower than certain value, it will stop supplying power, and display screen will stop displaying. When the battery supplies power normally, unplug AC power line, turn off equipment battery switch to completely cut off power, and the display screen will not display.

### U disk data time parameter setting

After unlocking, press setting, digit switch, temperature adjustment keys for more than 5s, the first two digits on refrigerating display screen shows 1P stably, frozen display screen will blinking display year (10 by default), and the year will increase by 1 for each press of temperature adjustment key, with circle display from 10 to 30, after setting press setting key to save, then the front two digits on refrigerating display screen shows 2P stably, frozen display screen will blinking display month (01 by default).

The month will increase by 1 for each press of temperature adjustment key, with circle display from 01 to 12, after setting press setting key to save, then the front two digits on refrigerating display screen shows 3P stably, frozen display screen will blinking display date (01 by default); the date will increase by 1day for each press of temperature adjustment key, with circle display from 01 to 31, after setting press setting key to save, then the front two digits on refrigerating display screen shows 4P stably, frozen display screen will blinking display month (01 by default); the time will increase by 1h for each press of temperature adjustment key, with circle display from 00 to 23, after setting press setting key to save, then the front two digits on refrigerating display screen shows 5P stably, frozen display screen will blinking display month (01 by default); the time will increase by 1min for each press of temperature adjustment key, with circle display from 00 to 59, after setting press setting key to save, and it will automatically exit if there is no key operation for 10s after setting.

## Control Panel

### HYCD-282

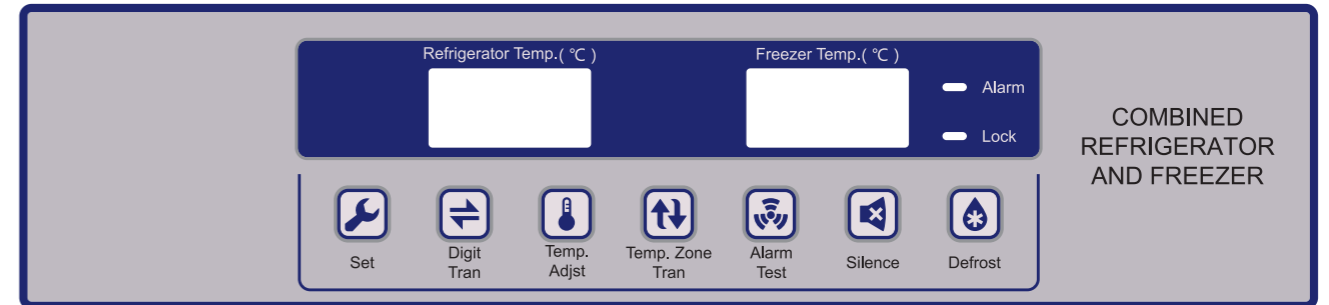

### HYCD-282A

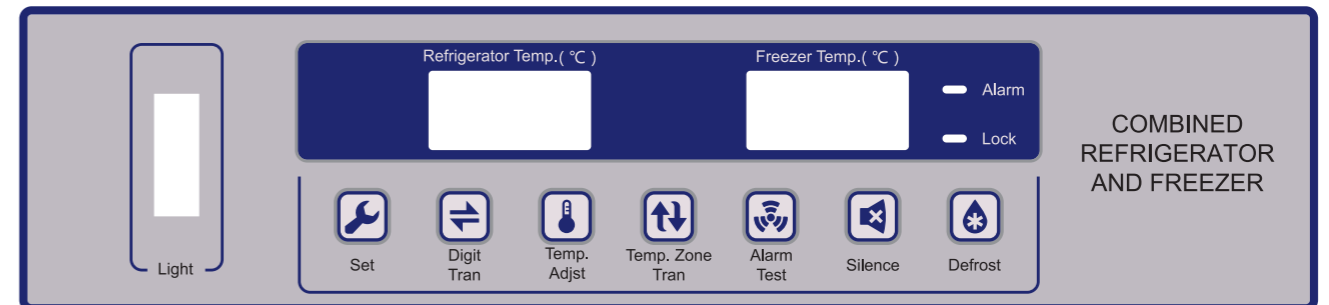

## Temperature setting

### 1. Unlock

When the lock indicator lights, all keys are locked except digits switch key, it should be unlocked before setting parameters, the unlock steps are as follows:

- Long press digits switch key for more than 5s, the display area shows F0, 0 digit flashing;
- Press temperature adjusting key, display area shows F1;
- Press setting key, lock indicator goes out, and the keyboard is unlocked.

### 2. User parameter setting

User can change the setting temperature, alarm value, start delay and other parameters of refrigerating chamber or freezing chamber through control panel. These settings are independent for refrigerating chamber and freezing chamber. The operations as refrigerating chamber setting will be shown on the display screen of refrigerating chamber on left side of display panel, and the parameter adjustment of freezing chamber will be shown on the refrigerating chamber on right side of display panel. The activated setting area will make blinking display, to activate another setting area, you can press temperature switch key.

#### ① Parameter inquiry and setting

- Press setting key under unlock status, the display screen activated by default will show L0, 0 digit flashing, then the temperature area can be changed by temperature area switch;
- Press temperature adjustment key to adjust L0 to L1, L2, L3, L4, L5;
- Adjust to designated parameter, and press setting value, the display screen will show the setting value of that area, and the value at units' digit will flash, the corresponding list of parameter code is as follows:

Parameter code	Parameter meaning	Parameter code	Parameter meaning
L0	Control temperature setting	L3	Current voltage inquiry
L1	High temperature alarm value setting	L4	Current environment temperature inquiry
L2	Low temperature alarm value setting	L5	Non-use setting

- Press digit switch key to change the flashing digit, press temperature adjustment key to change current digit value;
- Press setting key when adjusting to required temperature, change and save parameters.

## Caution

- The setting temperature by default of cold storage area is 5°C, the frozen area is -40°C;
- For non-use setting, the default value is 1, meaning the normal operation of current activated area, 0 means the current activated area is disabled;
- Voltage and environment temperature can only be inquired, but can't be set .
- High-low temperature alarm value can be set within the following range:  
The highest setting temperature+5°C≥high temperature alarm value≥setting temperature+5°C  
The lowest setting temperature-5°C≤low temperature alarm value≤setting temperature-5°C
- The “┆” in front of figure represents “+”.

#### ② Start delay setting

- In unlock status, press setting key and temperature adjustment key for 5s, the display screen activated by default will show the delay time of current area compressor, then the temperature area can be changed by temperature area switch;
- Press temperature adjustment key to change start delay time;
- Press setting key when adjusting to required value, change and save parameters.

#### ③ Freezing chamber defrost

In unlock status, press freezing defrost for more than 5s, the refrigeration system of freezing chamber will stop running, the display screen of cold storage area will show dF, it can't make auto reply in this status, but long press freezing defrost key under unlock status again for more than 5s to exit defrost mode, dF will disappear from display screen of cold storage area after successful exit.

## Caution

- In all parameter adjustment, if there is no operation within 10s, system will save current setting and exit parameter setting mode;
- For parameter adjustment, frozen area setting is activated by default for first use, if it needs to switch to cold storage area setting, press temperature switch key. If it is not for first use, the final set temperature area is activated by default;

## U disk data reading method

U disk interface is on the right of refrigerator-freezer top display board. After inserting U disk to interface, cabinet will automatically identify and import temperature data. Meanwhile press setting and temperature area switch key on display board for 5s, check whether data is imported to U disk. If not, display screen will show "USB" "....."; or it will show "USB""OK". Unplug U disk after importing, and open the data in computer by text or excel. This product can save the cabinet temperature data in recent 10 years, if it is more than 10 years, the previous data will be replaced automatically.