

Operating Instructions
Original Operating Instructions

Cubis®

MCE Models
Semi-micro-, Analytical and Precision Balances

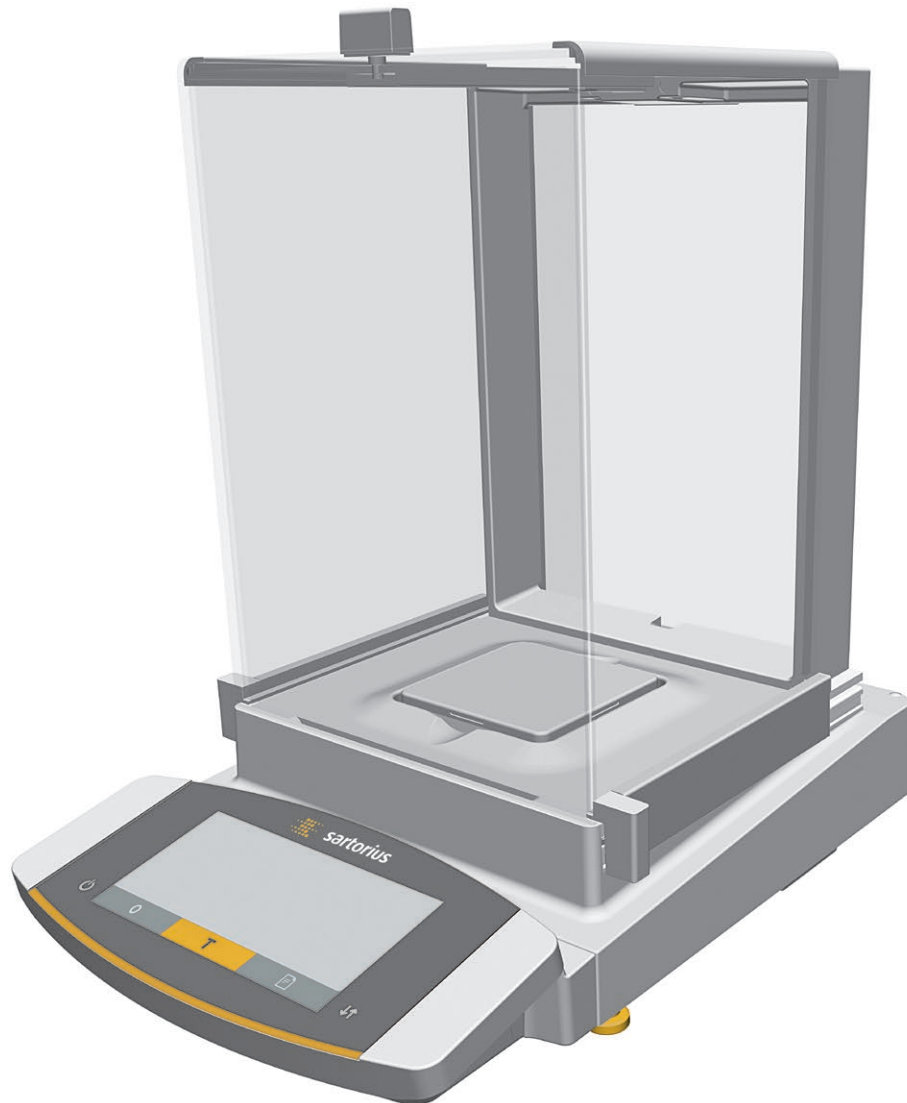

Contents

| | | | |
|--|----|--|----|
| 1 About these Instructions | 5 | 5.6 Installing a Device with an Analytical Draft Shield or Flat Glass Draft Shield | 29 |
| 1.1 Scope | 5 | 5.6.1 Positioning the Weighing Pan and Associated Components | 29 |
| 1.2 Symbols Used..... | 5 | 5.6.2 Installing the Analytical Draft Shield..... | 30 |
| 1.2.1 Warnings in Operating Instructions..... | 5 | 5.6.3 Installing the Flat Glass Draft Shield | 31 |
| 1.2.2 Other Symbols | 5 | 5.7 Installing a Device with a Frame Draft Shield | 32 |
| 1.3 Target Groups..... | 6 | 5.7.1 Positioning the Weighing Pan and Associated Components | 32 |
| 2 Safety Instructions | 7 | 5.8 Connecting the Electronics Module (Only for Semi-microbalance) | 32 |
| 2.1 Intended Use | 7 | 5.9 Setting Up the Cable Entry (Only for a Device with a Manual Analytical Draft Shield)..... | 33 |
| 2.2 Personnel Qualification..... | 7 | 5.10 Acclimatization | 33 |
| 2.3 Significance of these Instructions..... | 7 | 6 Getting Started | 34 |
| 2.4 Proper Working Order of the Device..... | 8 | 6.1 Connecting Electronic Components | 34 |
| 2.5 Symbols on the Device | 8 | 6.2 Installing the AC Adapter..... | 34 |
| 2.6 Electrical Equipment..... | 8 | 6.3 Connecting the Power Supply..... | 35 |
| 2.6.1 Damage to the Electrical Equipment of the Device | 8 | 7 System Settings | 36 |
| 2.6.2 Working on the Device's Electrical Equipment..... | 8 | 7.1 Performing System Settings..... | 36 |
| 2.6.3 AC Adapter and Power Supply Cable..... | 8 | 7.2 Switching Off the isoCAL Function..... | 36 |
| 2.7 Conduct in an Emergency..... | 8 | 7.3 Parameter List | 37 |
| 2.8 Accessories, Consumables, and Spare Parts | 9 | 7.3.1 Parameters in the "Setup" Main Menu | 37 |
| 2.9 Personal Protective Equipment | 9 | 7.3.2 Parameters in the "Device" Main Menu..... | 39 |
| 2.10 Glass Breakage..... | 9 | 7.3.3 Parameters in the "Data Output" Main Menu..... | 44 |
| 3 Device Description | 10 | 7.3.4 Parameters in the "Applications" Main Menu..... | 45 |
| 3.1 Device Overview | 10 | 7.3.5 Parameters in the "Input" Main Menu | 47 |
| 3.2 Draft Shield | 11 | 7.3.6 Parameters in the "Language" Main Menu.. | 48 |
| 3.3 Weighing Pan and Associated Components..... | 12 | 7.3.7 Parameters in the "Unit 1", "Unit 2", "Unit 3", and "Unit 4" Application Menus.. | 48 |
| 3.4 Connections and Components on the Weighing Module | 13 | 8 Operation | 49 |
| 3.4.1 Analytical Balance and Precision Balance.. | 13 | 8.1 Switching the Device On and Off | 49 |
| 3.4.2 Semi-microbalance with Electronics Module | 13 | 8.2 Leveling the Device..... | 49 |
| 3.5 Connections and Components on the Electronics Module | 14 | 8.3 Opening and Closing the Motorized Draft Shield (Only for Devices with a Motorized Draft Shield) .. | 49 |
| 3.6 Connections on the Control Unit..... | 14 | 8.4 Preparing Weighings..... | 50 |
| 3.7 Conformity-assessed Devices..... | 15 | 8.5 Weighing | 50 |
| 3.8 Symbols on the Device | 15 | 8.6 Overview of Calibration, Adjustment, and Linearization | 50 |
| 4 Operating Concept | 16 | 8.7 Adjusting with the isoCAL Function | 51 |
| 4.1 Operating Display in Weighing Mode..... | 16 | 8.8 Internally Calibrating and Adjusting the Device ... | 51 |
| 4.2 Operating Display in the Menu | 17 | 8.9 Externally Calibrating and Adjusting the Device (Not for Conformity-assessed Models) | 52 |
| 4.3 Buttons and Keys on the Operating Display..... | 17 | 8.10 Printing Results | 54 |
| 4.4 Displays in the Operating Display | 18 | 8.11 Weighing and Printing with ID Marking..... | 54 |
| 4.5 Menu Structure..... | 20 | 8.12 Turning the Ionizer On/Off (Optional) | 55 |
| 4.5.1 Overview of the Device Settings Menu..... | 20 | 8.13 Running Applications (Examples) | 55 |
| 4.6 Navigating the Menus..... | 24 | 8.13.1 Executing the "Toggle Between Weight Units" Function..... | 55 |
| 5 Installation | 26 | 8.13.2 Running the "Statistics" Application | 56 |
| 5.1 Scope of Delivery..... | 26 | | |
| 5.2 Selecting an Installation Site | 26 | | |
| 5.3 Unpacking the Device..... | 27 | | |
| 5.4 Removing the Control Unit | 27 | | |
| 5.4.1 Positioning the Control Unit..... | 27 | | |
| 5.5 Preparing Below-cell Weighing..... | 28 | | |

| | | |
|-----------|--|----|
| 9 | Cleaning and Maintenance | 57 |
| 9.1 | Preparing a Device with an Analytical Draft Shield or Flat Glass Draft Shield | 57 |
| 9.2 | Preparing a Device with a Frame Draft Shield | 58 |
| 9.3 | Cleaning the Device | 58 |
| 9.4 | Assembling and Connecting the Device | 59 |
| 9.5 | Maintenance Schedule | 59 |
| 9.6 | Performing a Software Update | 60 |
| 10 | Malfunctions | 61 |
| 10.1 | Status Messages | 61 |
| 10.2 | Warning Messages | 61 |
| 10.3 | Troubleshooting | 63 |
| 11 | Decommissioning | 64 |
| 11.1 | Decommissioning the Device | 64 |
| 12 | Transport | 64 |
| 12.1 | Transporting the Device | 64 |
| 13 | Storage and Shipping | 65 |
| 13.1 | Storage | 65 |
| 13.2 | Returning Device and Parts | 65 |
| 14 | Disposal | 66 |
| 14.1 | Information on Decontamination | 66 |
| 14.2 | Dispose of Device and Parts | 66 |
| 14.2.1 | Information on Disposal | 66 |
| 14.2.2 | Disposal | 66 |
| 15 | Technical Data | 67 |
| 15.1 | Dimensions and Weight | 67 |
| 15.1.1 | Semi-microbalance | 67 |
| 15.1.2 | Analytical Balance | 67 |
| 15.1.3 | Precision Balance | 67 |
| 15.2 | Power Supply | 67 |
| 15.2.1 | Device | 67 |
| 15.2.2 | Power Supply Unit | 68 |
| 15.2.3 | Safety of Electrical Equipment | 68 |
| 15.2.4 | Electromagnetic Compatibility | 68 |
| 15.3 | Materials | 69 |
| 15.4 | Integrated Clock | 69 |
| 15.5 | Backup Battery | 69 |
| 15.6 | Ambient Conditions | 69 |
| 15.6.1 | Installation Site | 69 |
| 15.6.2 | Ambient Temperature for the isoCAL Function | 70 |
| 15.6.3 | Protection Class | 70 |
| 15.7 | Metrological Data | 71 |
| 15.7.1 | Models MCE225S MCE225P MCE125S MCE125P | 71 |
| 15.7.2 | Models MCE524S MCE524P MCE324S MCE324P | 72 |
| 15.7.3 | Models MCE224S MCE124S MCE5203S MCE5203P | 73 |
| 15.7.4 | Models MCE3203S MCE2203S MCE2203P MCE1203S | 74 |
| 15.7.5 | Models MCE623S MCE623P MCE323S MCE5202S | 75 |
| 15.8 | Recommended Calibration Weight | 76 |
| 15.9 | isoCAL Function | 76 |
| 15.9.1 | Models MCE225S MCE225P MCE125S MCE125P MCE524S MCE524P MCE324S MCE324P MCE224S MCE124S MCE5203S MCE5203P MCE3203S MCE2203S MCE2203P MCE1203S | 76 |
| 15.9.2 | Models MCE5202S MCE623S MCE623P MCE323S | 77 |
| 15.10 | Interfaces | 77 |
| 15.10.1 | Specifications for the COM-RS232 Interface | 77 |
| 15.10.2 | Specifications for the USB-A Interface | 77 |
| 15.10.3 | Specifications for the USB-B Interface | 77 |
| 16 | Accessories | 78 |
| 16.1 | Accessories | 78 |
| 16.1.1 | Printers and Communication | 78 |
| 16.1.2 | Displays and Input/Output Elements | 78 |
| 16.1.3 | Hardware for Pipette Calibration | 79 |
| 16.1.4 | Filter Balance and Antistatic Accessories .. | 79 |
| 16.1.5 | Special Applications | 79 |
| 16.1.6 | Weighing Tables | 79 |
| 16.1.7 | Weighing Accessories | 79 |
| 16.1.8 | Sample Holder | 80 |
| 17 | Sartorius Service | 81 |
| 18 | Conformity & Certificates | 81 |
| 18.1 | EU Declaration of Conformity | 81 |
| 18.2 | Certificate of Compliance | 83 |
| 18.3 | FCC Supplier's Declaration of Conformity | 85 |

1 About these Instructions

1.1 Scope

These instructions are part of the device. These instructions apply to the device in the following versions:

| Device | Model |
|---|--|
| Cubis® semi-microbalance, with manual or motorized draft shield, with or without ionizer | MCE125P-... MCE125S-... MCE225P-... MCE225S-... |
| Cubis® analytical balance, with manual or motorized draft shield, with or without ionizer | MCE124S-... MCE224S-... MCE324P-... MCE324S-... MCE524P-... MCE524S-... |
| Cubis® precision balance, with frame draft shield, flat glass draft shield, manual or motorized draft shield, with or without ionizer | MCE1203S-... MCE2203P-... MCE2203S-... MCE3203S-... MCE323S-... MCE5202S-... MCE5203P-... MCE5203S-... MCE623P-... MCE623S-... |

1.2 Symbols Used

1.2.1 Warnings in Operating Instructions

WARNING

Denotes a danger with the risk that death or severe injury may result if it is **not** avoided.



CAUTION

Denotes a hazard that may result in moderate or minor injury if it is **not** avoided.

NOTICE

Denotes a danger with the risk that property damage may result if it is **not** avoided.

1.2.2 Other Symbols

-  Required action: Describes actions which must be carried out.
-  Result: Describes the result of the actions carried out.
- [] Text inside brackets refers to control and display items.
- [] Text inside brackets indicates status, warning, and error messages.
-  Indicates information for legal metrology for conformity-assessed (verified) devices. Conformity-assessed devices are also referred to as "verified" in these instructions.

Figures on the Operating Display

The figures on the operating display of the device may deviate from those in these instructions.

1.3 Target Groups

These instructions are addressed to the following target groups. The target groups must possess the specified knowledge.

| Target group | Knowledge and responsibilities |
|--------------|--|
| User | The user is familiar with the operation of the device and the associated work processes. They understand the hazards which may arise when working with the device and know how to prevent them. They have been trained in the operation of the device. The training is carried out by the operating engineer/laboratory manager or the operator of the device. |
| Operator | The operator of the device is responsible for compliance with safety requirements and workplace safety regulations. The operator must ensure that all persons who work with the device have access to the relevant information and are trained in working with the device. |

2 Safety Instructions

2.1 Intended Use

The device is a high-resolution balance, which can be used in laboratories. The device was developed for the accurate determination of the mass of materials in liquid, paste, powder, or solid form.

Appropriate containers must be used for loading each type of material. The device can be used in stand-alone operation or can be operated on a PC.

The device is exclusively designed for use according to these instructions. Any further use beyond this is considered **improper**.

If the device is **not** used properly: The protective systems of the device may be impaired. This can lead to unforeseeable personal injury or property damage.

Operating Conditions for the Device

Do **not** use the device in potentially explosive environments. The device may only be used indoors.

The device may only be used with the equipment and under the operating conditions described in the Technical Data section of these instructions.

Modifications to the Device

You may **not** modify or repair the device or make any technical changes. Any retrofitting or technical changes to the device are only permitted with prior written permission from Sartorius.

2.2 Personnel Qualification

All persons working on the device must possess the necessary knowledge and responsibilities (see Chapter "1.3 Target Groups", page 6).

If **no** qualifications are indicated for the actions described in these instructions: The actions described are addressed to the "User" target group.

If individual actions must be carried out by other target groups or by Sartorius Service personnel: The qualification required will be indicated in the description of the action.

2.3 Significance of these Instructions

Failure to follow the instructions in this manual can have serious consequences, e.g., exposure of individuals to electrical, mechanical, or chemical hazards.

- ▶ Before working with the device: Read the instructions carefully and completely.
- ▶ If these instructions are lost: Request a replacement or download the latest version from the Sartorius website (www.sartorius.com).
- ▶ Ensure that the information contained in these instructions is available to all individuals working on the device.

2.4 Proper Working Order of the Device

A damaged device or worn parts may lead to malfunctions or cause hazards which are difficult to recognize.

- ▶ Only operate the device when it is safe and in perfect working order.
- ▶ Have any malfunctions or damage repaired immediately by Sartorius Service.

2.5 Symbols on the Device

All symbols appearing on the device, such as warnings and safety labels, must be legible.

- ▶ Do **not** conceal, remove, or modify the symbols.
- ▶ Replace the symbols if they become illegible.

2.6 Electrical Equipment

2.6.1 Damage to the Electrical Equipment of the Device

Damage to the electrical equipment of the device, e.g. damage to the insulation, can be life-threatening. Contact with parts under voltage represents a direct danger to life.

- ▶ If the device's electrical equipment is defective, disconnect the device from the power supply and contact Sartorius Service.
- ▶ Keep live parts away from moisture. Moisture can cause short circuits.

2.6.2 Working on the Device's Electrical Equipment

Only Sartorius Service personnel may work on or modify the electrical equipment of the device. The device may only be opened by Sartorius Service personnel.

2.6.3 AC Adapter and Power Supply Cable

Serious injury can result, e.g. from electric shocks, if an unsuitable and inadequately dimensioned power supply cable or unsuitable power supply is used.

- ▶ Only use the original power supply cable and power supply.
- ▶ If the power supply or power supply cable must be replaced: Contact Sartorius Service. Do **not** repair or modify the power supply or power supply cable.

2.7 Conduct in an Emergency

If there is immediate danger of personal injury or if there is a risk of damage to the device, e.g., due to malfunctions or dangerous situations, the device must be immediately taken out of operation.

- ▶ Disconnect the device from the power supply cable by disconnecting the power supply cable.
- ▶ Malfunctions should be remedied by Sartorius Service.

2.8 Accessories, Consumables, and Spare Parts

The use of unsuitable accessories, consumables, and spare parts can affect the functionality and safety of the device and have the following consequences:

- Risk of injury to persons
 - Damage to the device
 - Malfunction of the device
 - Device failure
-
- ▶ Only use approved accessories, consumables, and spare parts supplied by Sartorius. Information on operational quality is available upon request from Sartorius.
 - ▶ Only use accessories, consumables, and spare parts that are in proper working order.

2.9 Personal Protective Equipment

Personal protective equipment protects against risks arising from the samples used.

- ▶ If the workplace or the measurement process in which the device is being used requires personal protective equipment: Wear personal protective equipment.

2.10 Glass Breakage

Glass components can break if they fall or are handled incorrectly. Glass fragments can cause cuts.

- ▶ Only lift the device by its base, **not** by the draft shield.
- ▶ When lifting and transporting, ensure that **no** personnel or objects are in the way.

3 Device Description

3.1 Device Overview

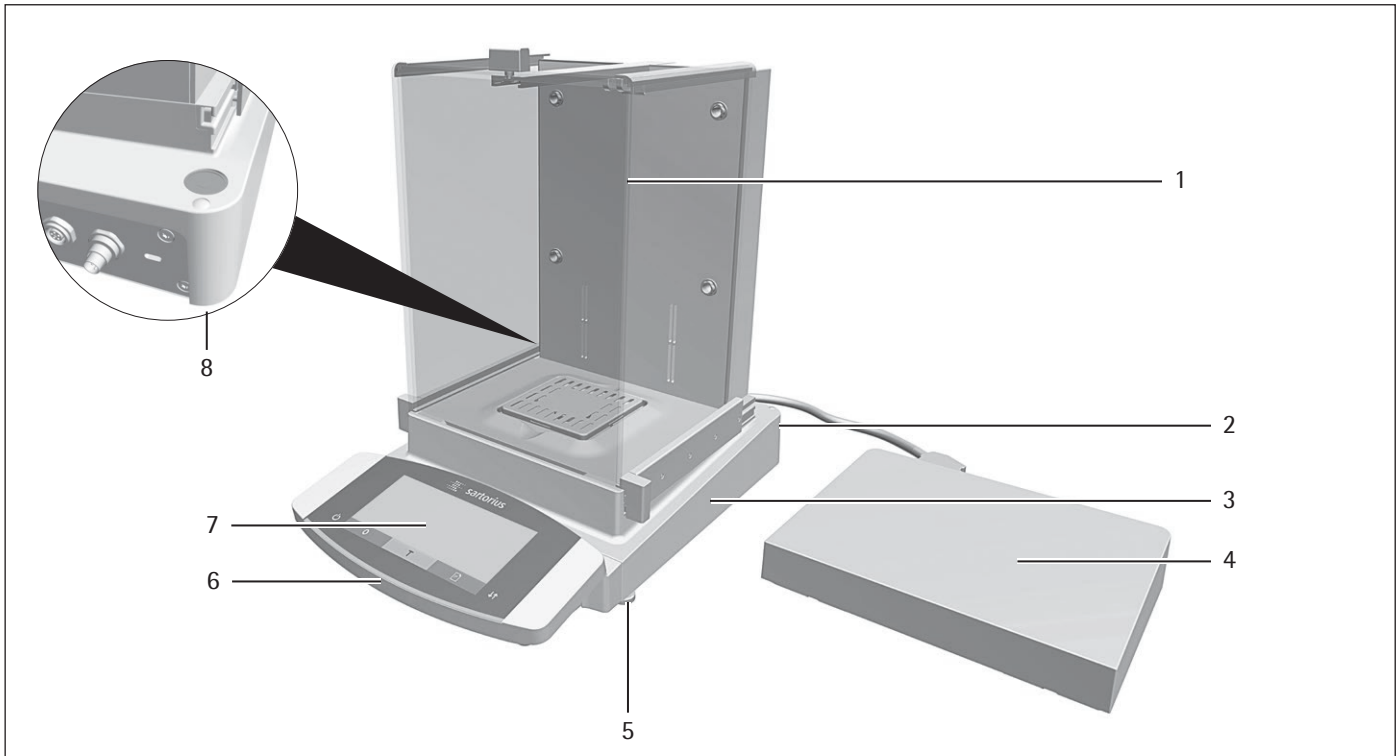

Fig. 1: Semi-microbalance with motorized draft shield with ionizer and electronics module (example)

| Pos. | Designation | Description |
|------|-------------------------|---|
| 1 | Weighing chamber | |
| 2 | Manufacturer's ID label | Not depicted |
| 3 | Weighing module | |
| 4 | Electronics module | Only for semi-microbalances with electronics module |
| 5 | Leveling foot | Motorically adjustable |
| 6 | Control unit | |
| 7 | Operating display | Touchscreen |
| 8 | Level | |

3.2 Draft Shield

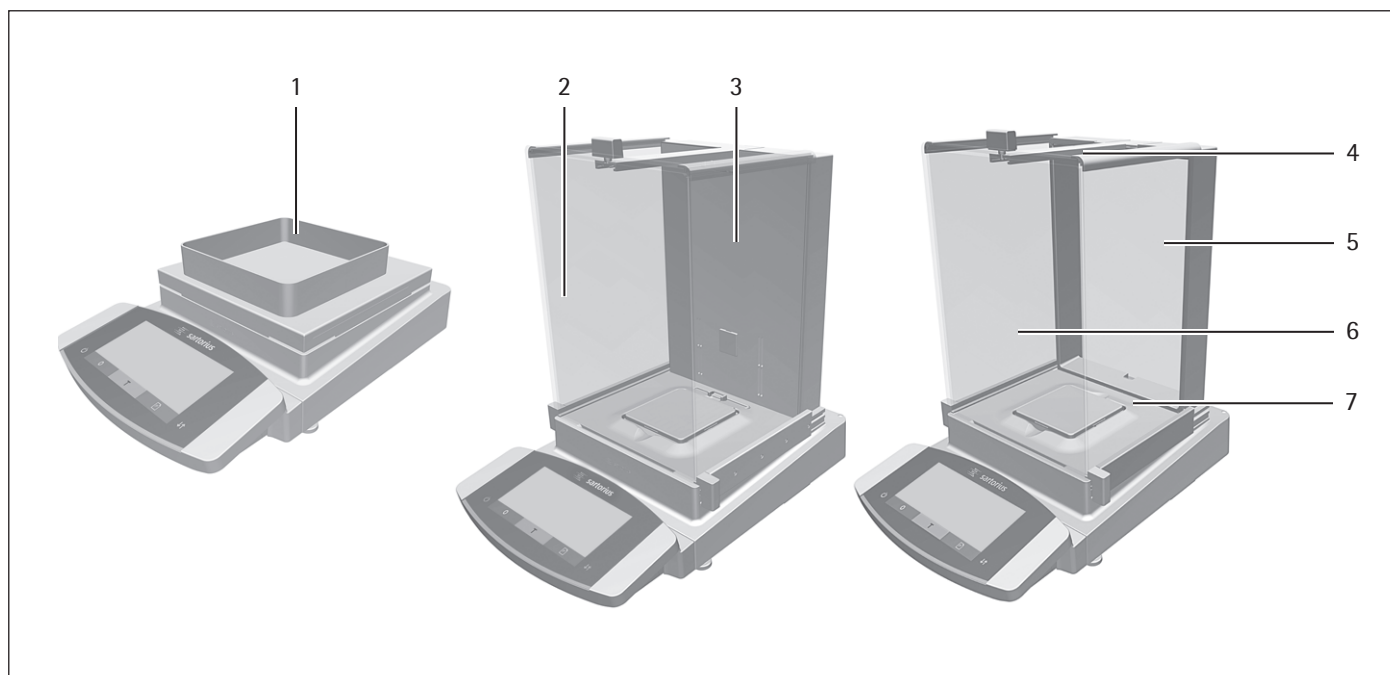

Fig. 2: Precision balance with frame draft shield, analytical balance with motorized analytical draft shield, and analytical balance with manual analytical draft shield (example)

| Pos. | Designation | Description |
|------|--------------------------|---|
| 1 | Frame draft shield | Is placed on the draft shield. |
| 2 | Analytical draft shield | Can be opened at the door handle of the upper panel or at the door handles of the side panels. Is motorized in some models. |
| 3 | Housing back plate | Manufactured from metal and plastic parts |
| 4 | Upper draft shield panel | Used to open the upper panel. Can be opened manually and is motorized in some models. |
| 5 | Rear panel | Glass |
| 6 | Front panel | Glass |
| 7 | Side panel | Can be opened manually and is motorized in some models. |

3.3 Weighing Pan and Associated Components

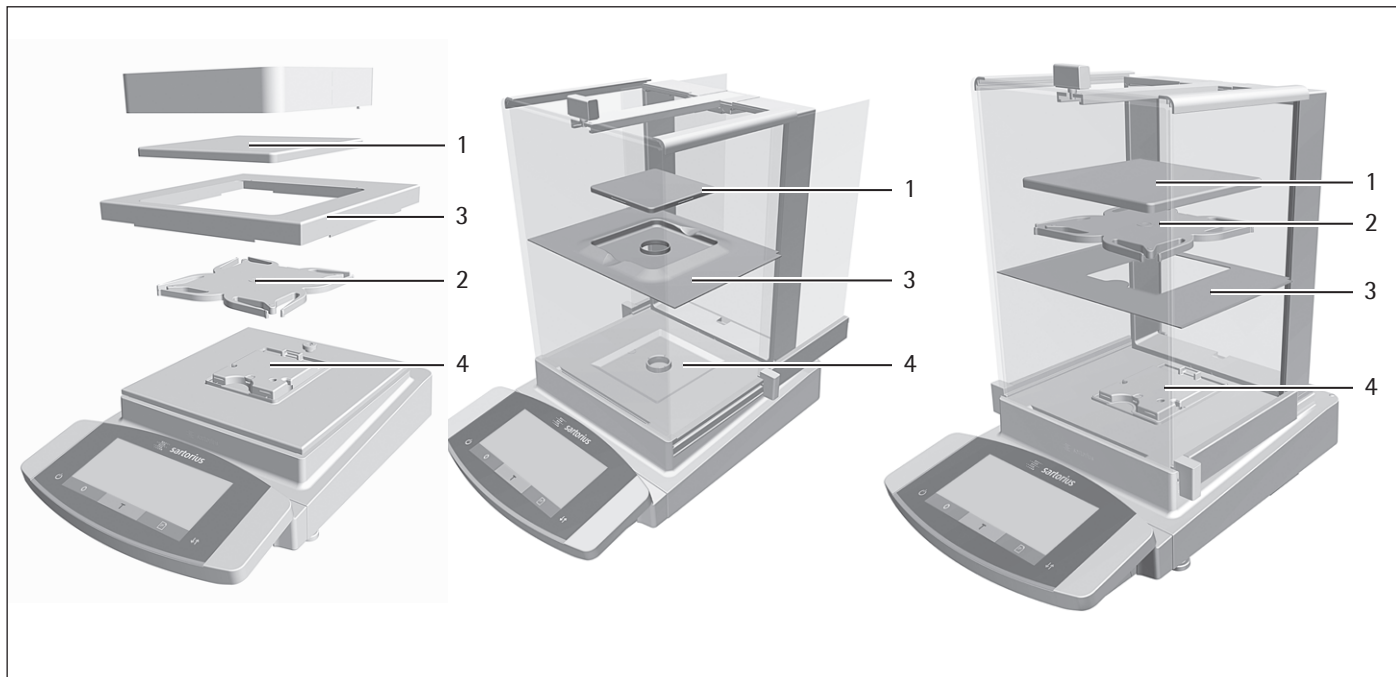

Fig. 3: Precision balances with frame draft shield, analytical balance with manual analytical draft shield (example)

| Pos. | Designation | Description |
|------|--------------|----------------------------------|
| 1 | Weighing pan | |
| 2 | Pan support | Only for models with pan support |
| 3 | Shield plate | |
| 4 | Pan retainer | |

3.4 Connections and Components on the Weighing Module

3.4.1 Analytical Balance and Precision Balance

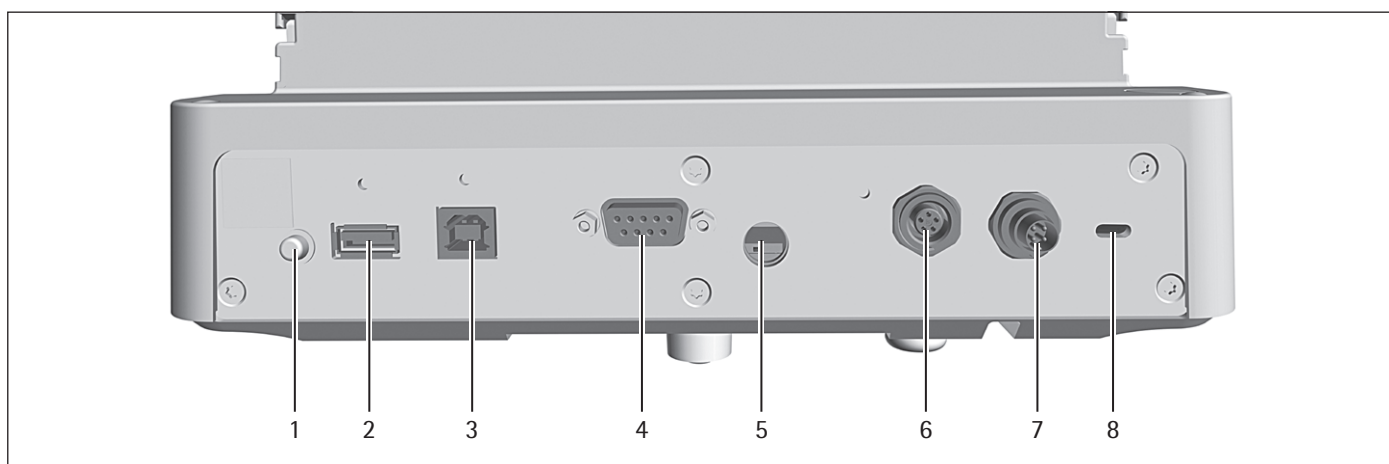

Fig. 4: Connections on the weighing module of the analytical balance and precision balance

| Pos. | Designation | Description |
|------|-----------------------|---|
| 1 | On key | Switches the device on from standby mode. |
| 2 | USB-A connection | For printers and for software updates via a USB mass storage device |
| 3 | USB-B connection | For connection to a PC |
| 4 | COM-RS232 connection | 9-pin, for connection to a PC or PLC |
| 5 | Access switch | Protects the device from changes to the device settings. Is sealed for conformity-assessed devices. |
| 6 | Peripheral connection | For connecting Sartorius accessories. |
| 7 | Power supply | For connection to the power supply |
| 8 | Slot | For attaching a "Kensington" anti-theft device |

3.4.2 Semi-microbalance with Electronics Module

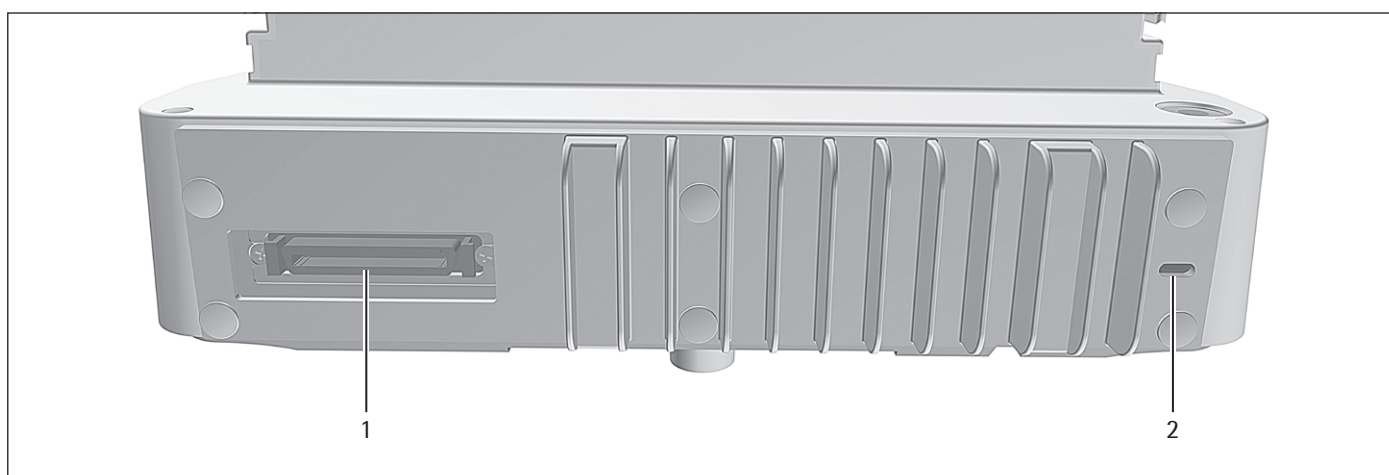

Fig. 5: Connections on the weighing module of the semi-microbalance with electronics module

| Pos. | Designation | Description |
|------|-------------------------------|--|
| 1 | Electronics module connection | For connecting the electronics module to the weighing module |
| 2 | Slot | For attaching a "Kensington" anti-theft device |

3.5 Connections and Components on the Electronics Module

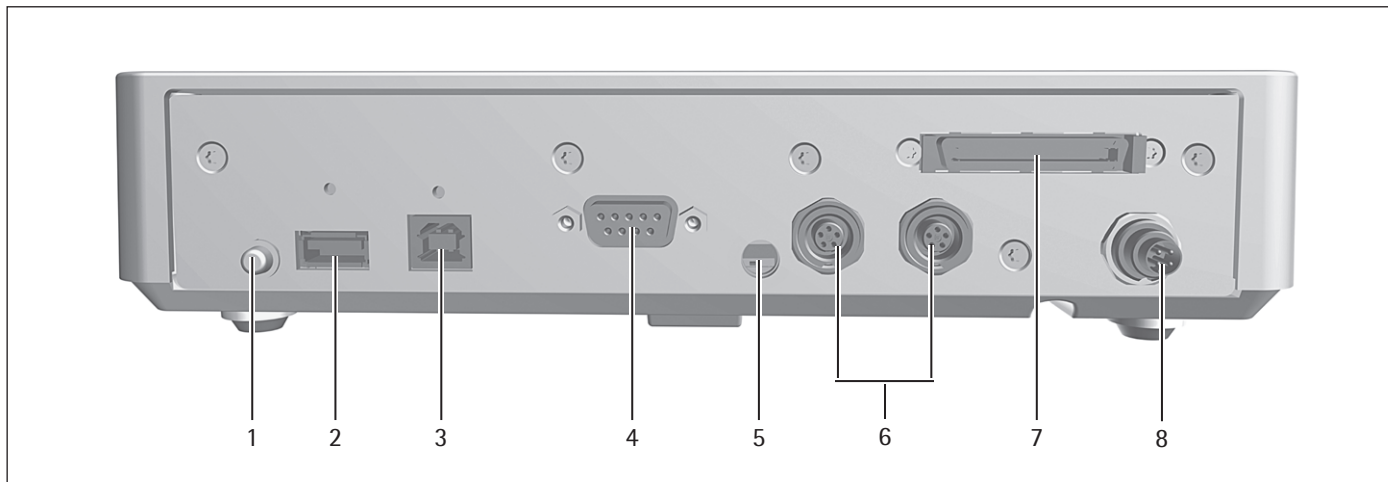

Fig. 6: Connections on the electronics module

| Pos. | Designation | Description |
|------|----------------------------|---|
| 1 | On key | Switches the device on from standby mode. |
| 2 | USB-A connection | For printers and for software updates via a USB mass storage device |
| 3 | USB-B connection | For connection to a PC |
| 4 | COM-RS232 connection | 9-pin, for connection to a PC or PLC |
| 5 | Menu access switch | Protects the device from changes to the device settings. Is sealed for conformity-assessed devices. |
| 6 | Peripheral connection | For connecting Sartorius accessories. |
| 7 | Weighing module connection | For connecting the electronics module to the weighing module |
| 8 | Power supply | For connection to the power supply |

3.6 Connections on the Control Unit

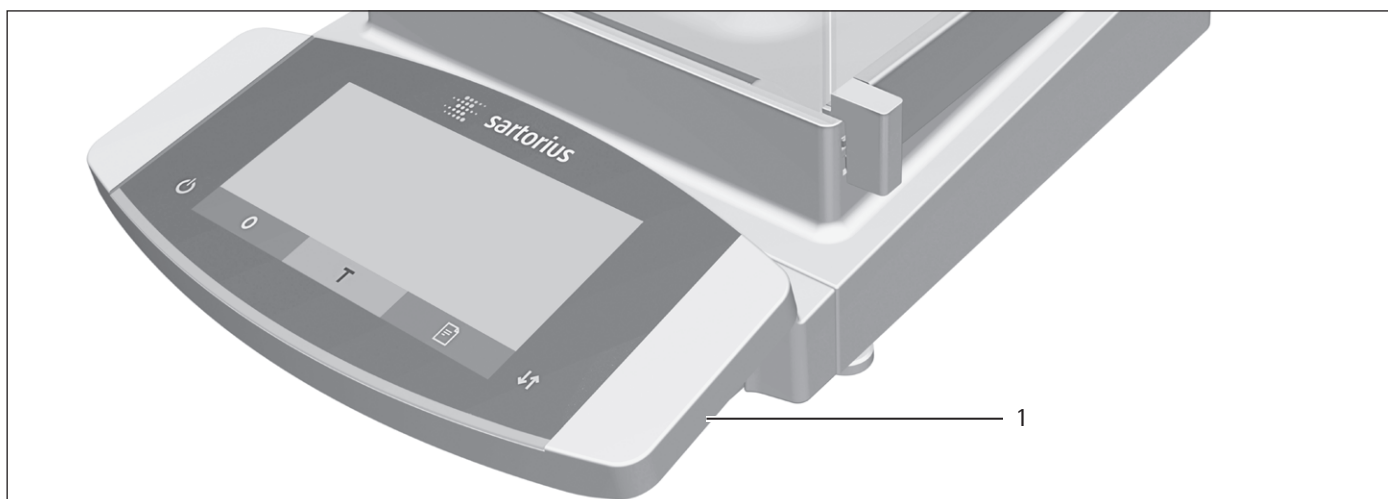

Fig. 7: Connections on the control unit

| Pos. | Designation | Description |
|------|----------------|---|
| 1 | USB connection | Concealed, no function, for Sartorius Service only |

3.7 Conformity-assessed Devices

Some settings of conformity-assessed models are protected against user changes, e.g. external calibration for devices in accuracy class II. This measure is intended to ensure the suitability of the devices for use in legal metrology.

3.8 Symbols on the Device

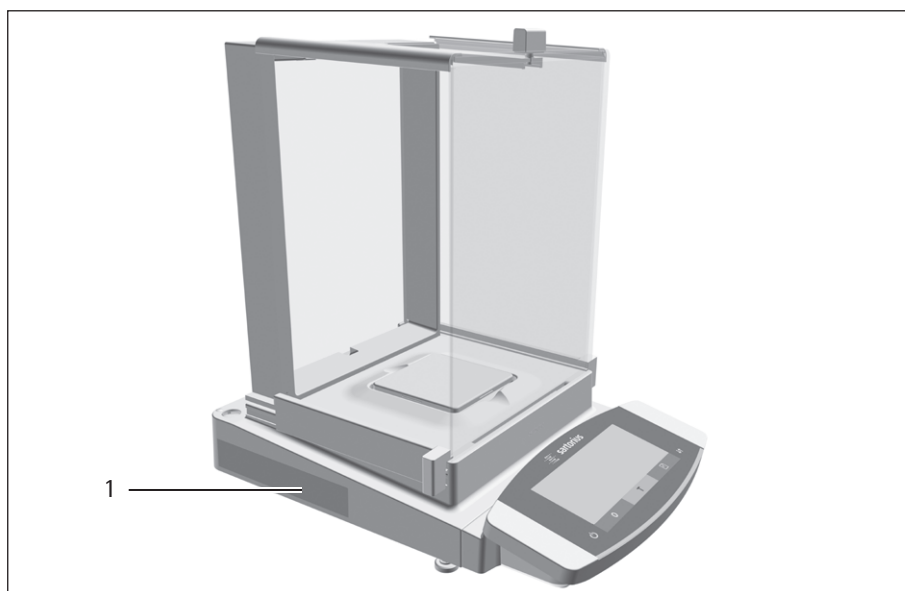



Fig. 8: ID label on the device

| Pos. | Designation | Description |
|------|-------------------------|---|
| 1 | Manufacturer's ID label | Displays the metrological data of the device. |

| Symbol | Meaning |
|---|---|
|  | During operation, parts in the device may be live. Only electricians may have access to and work on these parts, such as for maintenance and repairs. |

4 Operating Concept

4.1 Operating Display in Weighing Mode

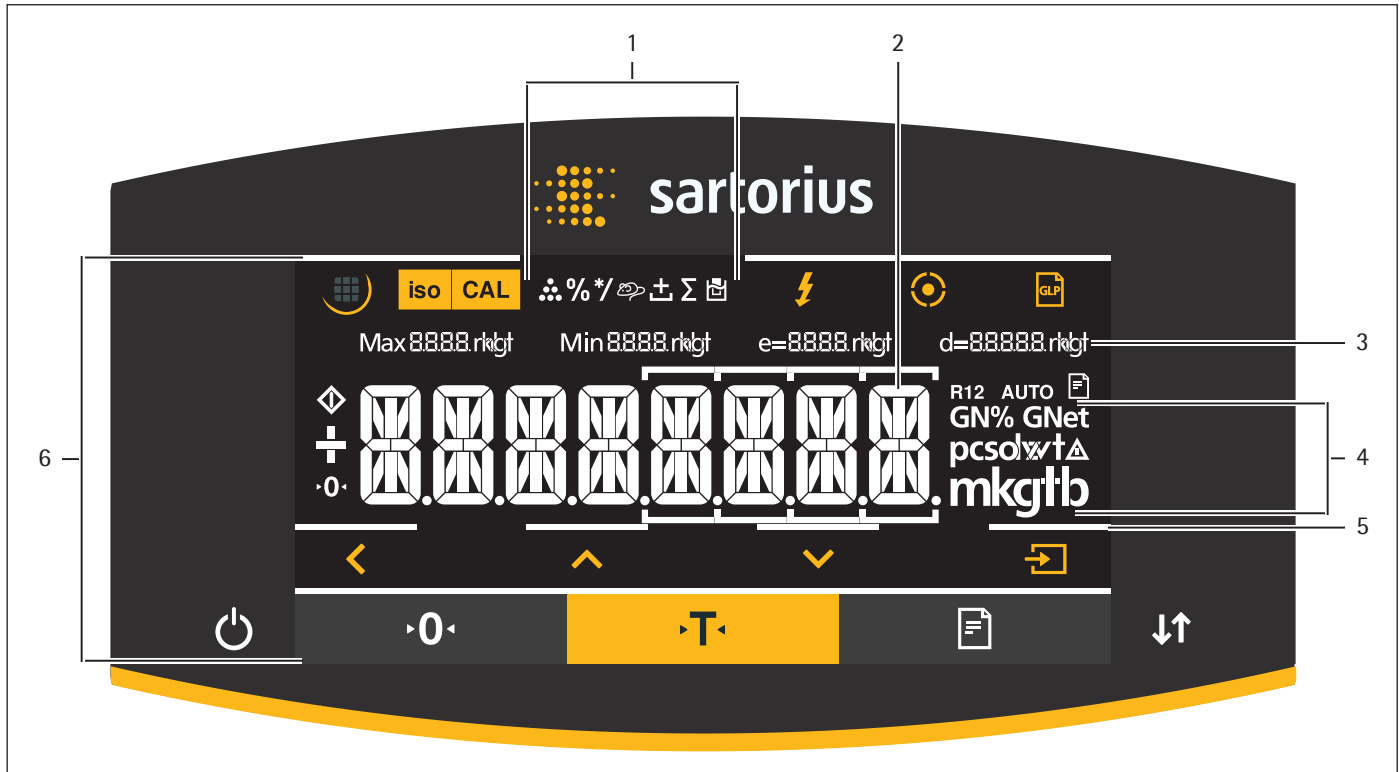

Fig. 1: Operating display in weighing mode (example)

| Pos. | Designation | Description |
|------|--------------------------------------|---|
| 1 | Symbols for the selected application | |
| 2 | Weight value display | In the selected basic unit. |
| 3 | Metrological data | |
| 4 | Weight units | Shows the selected basic unit, e.g. grams, [g]. |
| 5 | Visual touch-feedback | Visual note on an active button or key. |
| 6 | Operating and display area | |

4.2 Operating Display in the Menu

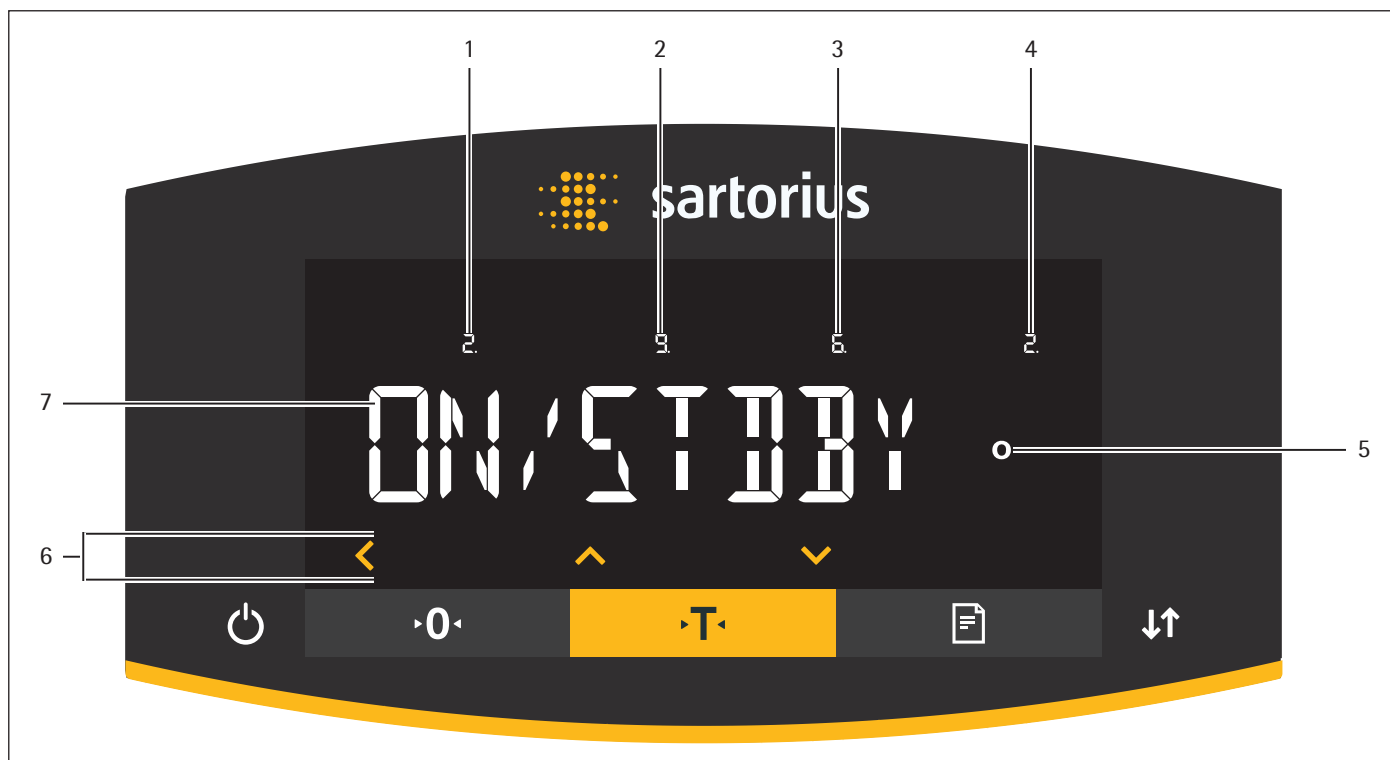













Fig. 2: Operating display in the menu (example)



| Pos. | Designation | Description |
|------|--------------------------------|---|
| 1 | Position in the 1st menu level | Shows the position of the displayed menu or configuration value in up to 4 menu levels. |
| 2 | Position in the 2nd menu level | |
| 3 | Position in the 3rd menu level | |
| 4 | Position in the 4th menu level | |
| 5 | [Computed values] display | Note on the set menu item |
| 6 | Operating area | |
| 7 | Name of the menu or setting | |

4.3 Buttons and Keys on the Operating Display

| Pos. | Symbol | Designation | Description |
|------|--------|-------------------|---|
| 1 | | [Menu] button | When the button is pressed: The settings menu opens. If the button is held down: It switches to version display. |
| 2 | | [isoCAL] button | Starts the isoCAL function. |
| 3 | | [Adjust] button | Starts the set calibration and adjustment function. |
| 4 | | [Ionizer] button | Starts an ionization process. |
| 5 | | [Leveling] button | Starts a leveling process. |
| 6 | | [GLP] button | <ul style="list-style-type: none"> Exits the GLP printout and starts printing the GLP footer. If the "Net-total", "Totalizing", or "Statistics" application is active: Prints and deletes the saved values and exits the application. |

| Pos. | Symbol | Designation | Description |
|------|---|--------------------------------------|--|
| 7 |  | [Toggle between weight units] button | If the "Toggle between weight units" function is active: <ul style="list-style-type: none"> – If the button is held down: Accesses the "Toggle between weight units" function menu. – When the button is pressed: Switches between the basic unit display and up to 4 other units. |
| 8 |  | [Invalid weight value] button | If a fault exists in the weighing module: Indicates the cause of this fault. |
| 9 |  | [Back] button | <ul style="list-style-type: none"> – In the menu: <ul style="list-style-type: none"> – When the button is pressed: Returns to the previous display. – If the button is held down: Saves the menu settings. – When entering digits: Selects the previous digit position. – For an active application: Exits the application and deletes the set reference value. |
| 10 |  | [Up] button | <ul style="list-style-type: none"> – In the menu: Scrolls through the menu levels or the available configuration values. – When entering digits: Increases the displayed value. |
| 11 |  | [Down] button | <ul style="list-style-type: none"> – In the menu: Scrolls through the menu levels or the available configuration values. – When entering digits: Decreases the displayed value. – In the main display of an active application: Accesses the display to set the reference values. |
| 12 |  | [Confirm] button | <ul style="list-style-type: none"> – In the menu: Accesses the displayed menu level or confirms the displayed configuration value. – When entering digits: Selects the next digit position. – In the main display of an active application: Starts the application process and saves the set reference value. |
| 13 |  | [On/Off] key | If the key is briefly pressed: Switches the operating display on. If the key is held down: Switches the operating display off. |
| 14 |  | [Zero] key | Zeros the device. |
| 15 |  | [Tare] key | Starts taring. |
| 16 |  | [Print] key | Exports the readouts to the integrated data interfaces. |
| 17 |  | [Change] key | <ul style="list-style-type: none"> – For models with a motorized draft shield: Opens or closes the doors on the draft shield. – For models without a motorized draft shield, if the "Toggle between weight units" function is active: <ul style="list-style-type: none"> – If the key is briefly pressed: Switches between the set weight units. – If the key is held down: Accesses the "Toggle between weight units" function menu. |

4.4 Displays in the Operating Display

| Pos. | Symbol | Designation | Description |
|------|---|--------------------|---|
| 1 |  | [Leveling] display | <ul style="list-style-type: none"> – Indicates that the device is leveled. – If the center circle is flashing: Indicates that the device is not leveled. |
| 2 |  | [Leveling] display | Flashes while the device is leveling. |

| Pos. | Symbol | Designation | Description |
|------|---|---------------------------------|--|
| 3 |  | [Counting] display | Indicates that the "Counting" application is selected. |
| 4 |  | [Weighing in percent] display | Indicates that the "Weighing in percent" application is selected. |
| 5 |  | [Calculation] display | Indicates that the "Calculation" application is selected. |
| 6 |  | [Animal weighing] display | Indicates that the "Animal weighing" application is selected. |
| 7 |  | [Net-total] display | Indicates that the "Net-total" application is selected. |
| 8 |  | [Totalizing] display | Indicates that the "Totalizing" application is selected. |
| 9 |  | [Density determination] display | Indicates that the "Density determination" application is selected. |
| 10 |  | [Statistics] display | Indicates that the "Statistics" application is selected. |
| 11 |  | [Busy] display | Indicates that the device is processing a command. |
| 12 |  | [Sign] display | Indicates whether the value being displayed is positive or negative. |
| 13 |  | [Zero] display | For some conformity-assessed devices: Indicates that the device has been zeroed. |
| 14 |  | [AUTO] display | Indicates that the "Animal weighing" application starts automatically. |
| 15 |  | [Data output] display | Indicates that the data output is active. |
| 16 |  | [Percent] display | Indicates that a percentage value is being displayed. |
| 17 |  | [Net] display | Indicates that a net value is being displayed. |
| 18 |  | [Computed value] display | <ul style="list-style-type: none"> – In the menu: Identifies the selected configuration value. – If the "Calculation" or "Density determination" application is active: Indicates that a calculated value is being displayed. |
| 19 |  | [Unit symbol] display | Indicates the set weight unit, e.g. [g] for "grams". |
| 20 |  | [Quantity] | Indicates that a quantity is being displayed. |
| 21 |  | [Invalid weight value] display | <ul style="list-style-type: none"> – Indicates that the display does not contain a weight value, rather it is the calculated result of an application, e.g. for the "Totalizing" application. – For conformity-assessed devices: Indicates a fault. The cause of this fault is displayed after pressing the [Change] key. |
| 22 |  | [Directional arrows] display | If leveling with the inclination sensor is active: Displays the direction of rotation of the leveling foot. |

4.5 Menu Structure

4.5.1 Overview of the Device Settings Menu

► Navigating in Menus (see Chapter 4.6, page 24).

| Level 1 | Level 2 | Level 3 | Description |
|---------|---------|---------------------------------------|---|
| SETUP | BALANCE | AMBIENT "Ambient conditions" | Enter the ambient conditions at the device's installation site. |
| | | APP FILT. "Application filter" | Equalize the load deviations in the display. The load deviations occur between the complete placement of the sample on the weighing pan and reaching the final result display. |
| | | STABIL. "Stability range" | Define the accuracy of the stability range. If the weight unit symbol appears, the weight readout is stable within the range indicated by the stability range |
| | | ST.DEL. "Stability delay" | Define the duration of the stability delay. The stability delay is used to bridge residual fluctuations in the vibration of the device in order to display reliable results. |
| | | ZERO/TAR. "Zeroing and taring" | Define the trigger for zeroing and taring. |
| | | AUTOZER. "Auto zero" | Activate/deactivate automatic control of the zero display. The deviations of a set fraction of scale intervals per second starting from the display zero point are automatically zeroed. |
| | | UNIT | Define the weight unit, e.g. grams, kilograms, pounds. Depending on the country-specific model version, not all weight units listed may be available. Some weight units may be blocked from use in conformity-assessed devices, depending on national verification laws. |
| | | DISP.DIG. | Define whether all decimal places are displayed. A lower display accuracy enables a faster display. The setting option is not available on conformity-assessed devices. |
| | | CAL/ADJ. "Adjust" | Define the function of the [Adjust] button. |
| | | CAL.SEQ. "Calibration sequence" | Define the sequence of the "Calibrate and adjust" function. |
| | | ON Z/T Tare/zero at power on | Activate/deactivate automatic taring when starting the device. |
| | | ISOCAL | Configure the isoCAL function. |
| | | CAL.UNIT "Calibration weight unit" | Define the weight unit for the calibration weight. |
| | | GEN.SERV. "General services" | MEN.RESET "Menu reset" |

| Level 1 | Level 2 | Level 3 | Description | |
|----------|--|---|---|---|
| DEVICE | RS-232 "COM-RS232, 9-pin" | DAT.REC. | Set the communication protocol for the connected device. | |
| | | BAUD | Set the baud rate for the connected device. | |
| | | PARITY | Set the parity for the connected device. | |
| | | STOPBIT | Set the number of stop bits. | |
| | | HANDSHK. | Set the handshake between the balance and the device. | |
| | | DATABIT | Set the number of data bits. | |
| | PC-USB "USB-B (Device/ Slave)" | DAT.REC. | Set the communication protocol for the connected PC. | |
| | | BAUD | Set the baud rate for the connected PC. | |
| | | PARITY | Set the parity for the connected PC. | |
| | | STOPBIT | Set the number of stop bits. | |
| | | HANDSHK. | Set the handshake between the device and the connected PC. | |
| | | DATABIT | Set the number of data bits. | |
| | USB "USB-A (Host/Master)" | DEV.USED "Device in use" | Display the device connected via USB-A. | |
| | | D.SHIELD "Draft shield" Only for devices with a motorized draft shield. | CONTROL | Activate/deactivate the motorized draft shield. |
| | | | IONIZER | Only for devices with an ionizer: Define whether an ionization process starts after closing the draft shield. |
| | IONIZER "Ionizer" Only for devices with an ionizer. | INT.ADJ. | Define the function of the draft shield when starting an internal adjustment. | |
| | | POWER | Define the intensity of the ionization process. | |
| | | DURATION | Define the duration of the ionization process in seconds. | |
| | LEVELING "Leveling" | LEVEL | Define the settings for the integrated inclination sensor. | |
| | | START | Define the trigger for automatic leveling. | |
| | MOTION.S. "Motion sensor" | CONTROL | Activate/deactivate the motion sensor. | |
| | | NUM.GEST. "Number" | Define the number of possible gestures. | |
| | | LEFT.CMD. | Define the function for the left gesture. | |
| | | RIGHT.CMD. | Define the function for the right gesture. | |
| | | UP.CMD. | Define the function for the up gesture. | |
| | | DOWN.CMD. | Define the function for the down gesture. | |
| | EXTRAS | MENU | Lock or unlock the menu's configuration parameters. | |
| | | SIGNAL | Set or deactivate the acoustic signal. | |
| | | KEYS | Activate/deactivate the key lock. | |
| | | ON MODE "Switch-on and switch-off options" | Configure the device's switch-on and switch-off options, e.g. switch between standby mode and operating mode. | |
| LIGHTING | | Activate/deactivate the lighting for the operating display. | | |

| Level 1 | Level 2 | Level 3 | Description | |
|------------------------------------|---|---|--|---|
| DATA.OUTP. "Data output" | COM. SBI "SBI communication" | COM.OUTP. | Configure the data output. | |
| | | STOP.AUTO | Define whether the automatic data output can be stopped and started with the [Print] key. | |
| | | AUTO.CYCL. "Time-dependent interval" | <ul style="list-style-type: none"> – Define an interval for the automatic data output. – Define whether data output takes place after an interval with or without balance stability. | |
| | | FORMAT | Define the data output format (characters per line). | |
| | | AUTO.TARE | Activate/deactivate automatic taring after the printout. | |
| | | PRNT.PARA. "Printout settings" | ACTIVATE "Triggers" | Define whether a printout is triggered via a software command or using the [Print] key. |
| | | | FORMAT | Define the format for the printout (characters per line). |
| | | | PRT.INIT. "Initializing" | Define the settings for printer initialization. |
| | GLP | | Define the settings for the GLP printout. | |
| | TAR./PRT. "Tare/print" | | Activate/deactivate automatic taring after every print process. | |
| | TIME | | Define the time format. | |
| | PC.DIRECT Direct transfer of data (PC) | DEC.SEPAR. | Define the decimal separator character. | |
| | | OUTP.FORM. | Define the output format for the data exchange between the balance and the PC. | |
| | APPLIC. "Applications" | WEIGH (Factory setting) | UNIT | Activate/deactivate the "Toggle between weight units" function for all applications. |
| COUNT | | RESOLUT. | Define the resolution of the weight value for the "Counting" application. | |
| | | REF.UPDT. "Reference updating" | Activate/deactivate automatic reference updating for the "Counting" application. | |
| PERCENT "Weighing in percent" | | DEC.PLCS "Decimal places" | Define the number of decimal places for the "Weighing in percent" application. | |
| NET-TOTL. "Net-total" | | COMP.PRT. "Component printout" | Activate/deactivate the component printout for the "Net-total" application. | |
| TOTAL "Totalizing" | | COMP.PRT. "Component printout" | Activate/deactivate the component printout for the "Totalizing" application. | |
| ANIMALW. "Animal weighing" | | ACTIVITY "Animal activity" | Define the level of activity of the sample for the "Animal weighing" application. | |
| | | START | Define the trigger for starting the animal weighing. | |
| CALC. "Calculation" | | METHOD | Define the method of calculation for the "Calculation" application. | |
| | | DEC.PLCS "Decimal places" | Define the number of decimal places for the "Calculation" application. | |
| DENSITY "Density determination" | | DEC.PLCS "Decimal places" | Define the number of decimal places for the "Density determination" application. | |

| Level 1 | Level 2 | Level 3 | Description |
|---------------------------------|------------------------------------|-----------------------------------|--|
| | STATIST. "Statistics" | COMP.PRT. "Component printout" | Activate/deactivate the component printout for the "Statistics" application. |
| | | TAR./STAT. "Tare/statistics" | Activate/deactivate automatic taring for the "Statistics" application. |
| UPDATE | | | Start a firmware update. The menu is only available if a USB mass storage device is connected. |
| INPUT | ID NO. | | Save the entered ID number for the device. |
| | LOT ID | | Activates/deactivates the printout of a line for the LOT ID in the GLP printout. The LOT ID can be entered in the line manually. |
| | DATE | | Set the date. |
| | TIME | | Set the time. |
| | USER.PASS. | | Set the user password. |
| | DEL.PASS. | | Delete the user password. The menu is only available if a user password is set. |
| | SERV.PASS. | | Activate the service mode. |
| | CAL.WT. "Calibration weight" | | Define the value of the external user calibration weight. |
| INFO "Device information" | VERSION "Version number" | | Display the software version number. |
| | SER. NO. "Serial number" | | Display the device's serial number. |
| | MODEL | | Display the device's model ID. |
| | APC VER. | | Display the version of the APC processor. |
| | BAC VER. | | Display the version of the BAC processor. |
| | MCU VER. | | Display the version of the MCU processor. |
| | WPC VER. "Draft shield version" | | Display the draft shield software version. |
| LANGUAGE | | | Change the menu language. |

Overview of the "Toggle between weight units" Function

► Navigating in Menus (see Chapter 4.6, page 24).

| Level 1 | Description |
|---------|---|
| Unit 1 | Define the displayed weight unit and the resolution for the 1st convertible unit. |
| Unit 2 | Define the displayed weight unit and the resolution for the 2nd convertible unit. |
| Unit 3 | Define the displayed weight unit and the resolution for the 3rd convertible unit. |
| Unit 4 | Define the displayed weight unit and the resolution for the 4th convertible unit. |

4.6 Navigating the Menus

Procedure



► To access the settings menu: Press the [Menu] button.



► To scroll through all menus in the same level: Press the [Up] or [Down] button.



► To switch to the displayed menu level: Press the [Confirm] button on the keypad.
 ► To scroll through the configuration values: Press the [Up] or [Down] button.
 ► To select the configuration value shown in the display or the displayed application: Press the [Confirm] button on the keypad.



▷ The [Value] display identifies the selected configuration value or the selected application.



► To return to the next higher menu level: Press the [Back] button.
 ► To exit the settings menu: In the main menu level, press the [Back] button.

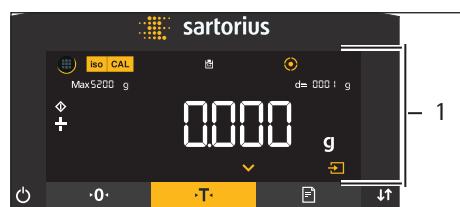

► If the start display (1) of a selected application is displayed:
 ► To start the application without changing the preset reference value: Press the [Confirm] button on the keypad.
 ► To change a reference value before starting the application, e.g. density value, divisor or reference quantity: Press the [Up] button.
 ▷ The reference value display is shown for the selected application.

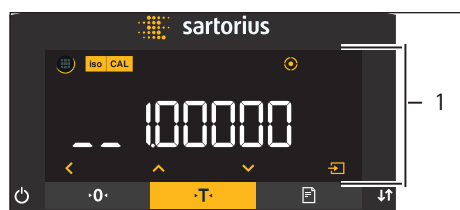

► If a reference value with decimal places needs to be selected in the reference value display (1) of a selected application, e.g. "Density determination" or "Calculation" applications:
 ▷ The selected digit position flashes.
 ► Use the [Up] or [Down] button to change the value for the selected digit position.
 ► If a digit position other than the last digit position is selected: Press the [Confirm] button to select the next digit position.
 ► If a digit position other than the first digit position is selected: Press the [Back] button to select the previous digit position.
 ► If the last digit position is selected: Press the [Confirm] button to save the displayed reference value and start the application process.
 ► If the first digit position is selected: Press the [Back] button to delete the displayed reference value and return to the application's status display.

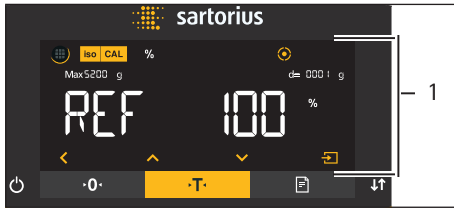

- ▶ If an integer reference value needs to be selected in the reference value display (1) of a selected application, e.g. "Weighing in percent" or "Animal weighing" applications:
 - ▶ Press the [Up] or [Down] button. This increases or decreases the reference value by 1.
 - ▶ Hold down the [Up] or [Down] button. This increases or decreases the reference value by 10.
 - ▶ To start the application: Press the [Confirm] button on the keypad.
 - ▶ To delete the displayed reference value and return to the application's status display: Press the [Back] button.
- ▶ If the results display (1) of a selected application is displayed:
 - ▶ To switch between the application results display and the set reference value display: Press the [Up] or [Down] button.
 - ▶ To exit the results, display and delete the set reference value and the result of the application: Press the [Back] button.

5 Installation

5.1 Scope of Delivery

| Item | Quantity |
|--|----------|
| Device | 1 |
| Weighing pan | 1 |
| Shield plate | 1 |
| For models with pan support: Pan support | 1 |
| Power supply unit | 1 |
| Country-specific power supply cable with test seal | 1 |
| USB connection cable | 1 |
| In-use dust cover for control unit | 1 |
| For models with analytical draft shield: Dust cover | 1 |
| For models without a draft shield: In-use dust cover for the weighing module | 1 |
| For semi-microbalances: Electronics module with power supply cable | 1 |
| For semi-microbalances: Connection cable for electronics module | 1 |

5.2 Selecting an Installation Site

Procedure

- Ensure that the following conditions are met at the installation site:

| Condition | Features |
|--------------------|--|
| Ambient conditions | Suitability tested (see Chapter "15.6 Ambient Conditions", page 69) |
| Setup surface | <p>Stable, even surface that is not exposed to vibrations</p> <p>Not directly against a wall</p> <p>Sufficiently dimensioned for the device and the peripheral devices (device space requirements see Chapter "15.1 Dimensions and Weight", page 67; peripheral device space requirements see instructions for the peripheral devices, e.g. printer)</p> <p>Sufficient load-bearing capacity for the device and the peripheral devices even when full (device weight see Chapter "15.1 Dimensions and Weight", page 67; weight of the peripheral devices see instructions for the peripheral devices, e.g. printer)</p> |
| Access | Barrier-free |

5.3 Unpacking the Device

Procedure

- ▶ Lift the device in the Styrofoam padding out of the packaging.
- ▶ Place the device in the Styrofoam padding on its side.
- ▶ Lift the Styrofoam padding off the device.
- ▶ **NOTICE** Glass breakage due to the incorrect handling of the device! Only lift the device by its base.
- ▶ Place the device on its base.
- ▶ Keep all parts of the original packaging, e.g. to return the device.

5.4 Removing the Control Unit

5.4.1 Positioning the Control Unit

The control unit can be removed. This enables the flexible setup of the control unit at the workplace.

Tool: 1 Torx Allen key, T20

Material: 1 soft support base

Requirements

- The weighing pan and the associated components have **not** been set up.
- For a device with an analytical draft shield or flat glass draft shield: The side panels and upper panel have **not** been fitted.

Procedure

- ▶ Turn the device on its side and place it on the soft support base.

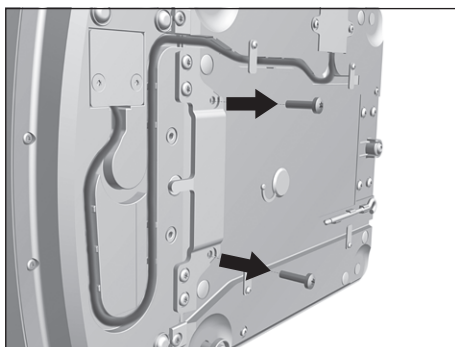
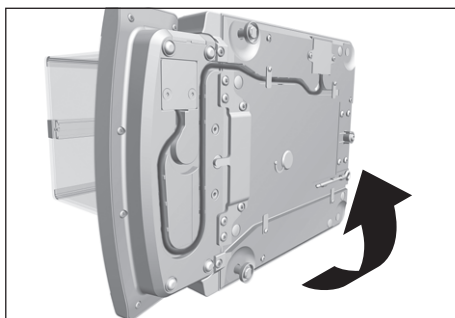

- ▶ To loosen the control unit's retainer: Use the Torx Allen key to remove both screws.
- ▶ Remove the control unit and re-insert both screws into the threaded holes.

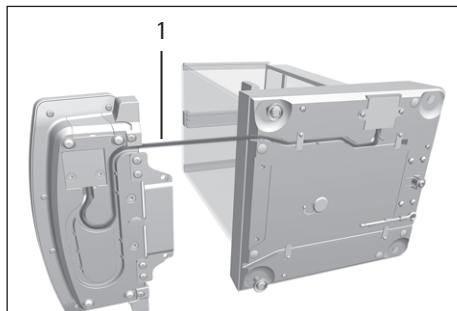

- ▶ Pull the connection cable between the control unit and the weighing module (1) out of the control unit's retainer and unroll it.

- ▶ Place the device back on the device base on a level surface.

5.5 Preparing Below-cell Weighing

Samples that **cannot** be placed on the weighing pan can be suspended below the device base and weighed using the below-cell weighing equipment.

M

In legal metrology:

- Do **not** use the below-cell weighing equipment.
- Do **not** open the cover of the below-cell weighing equipment.

Material: 1 soft support base

Requirements

- The weighing pan and the associated components have **not** been set up.
- For a device with an analytical draft shield or flat glass draft shield: The side panels and upper panel have **not** been fitted.

Procedure

- ▶ Turn the device on its side and place it on the soft support base.

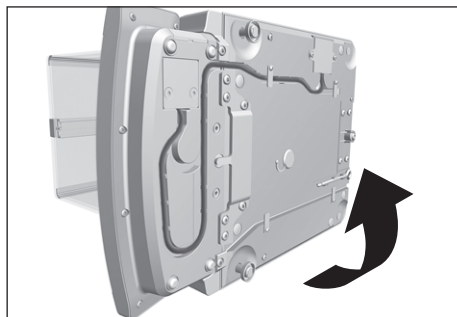

- ▶ Remove the hook for below-balance weighing (1) from the retainer on the underside of the base of the device.

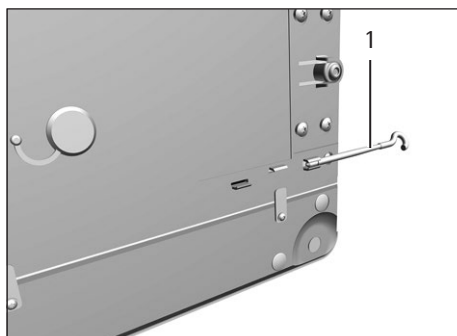

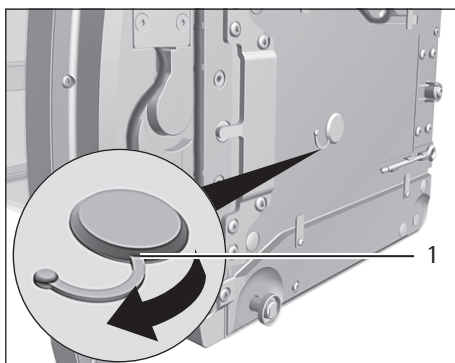

- ▶ Pull the cover of the below-balance weighing equipment (1) out.

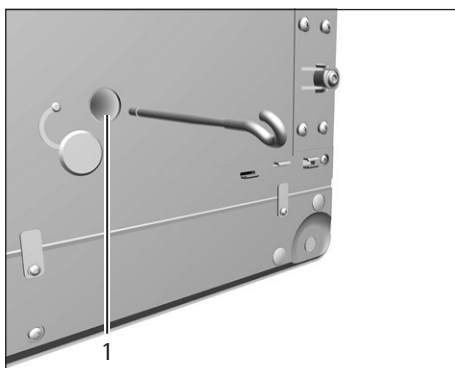

- ▶ **NOTICE** Damage to the device from cross-threading! Ensure that the hook for below-balance weighing is inserted straight into the thread (1).

- ▶ Install a draft protection shield.
- ▶ Suspend the sample on the hook for below-balance weighing, e.g. with a wire.
- ▶ To cover the below-balance weighing equipment after weighing:
 - ▶ Remove the hook for below-balance weighing from the thread.
 - ▶ Return the hook for below-balance weighing to its retainer on the underside of the weighing module.
 - ▶ Re-insert the cover of the below-balance weighing equipment.
- ▶ Place the device back on the device base on a level surface.

5.6 Installing a Device with an Analytical Draft Shield or Flat Glass Draft Shield

5.6.1 Positioning the Weighing Pan and Associated Components

Procedure

- ▶ Place the shield plate (1) on the base of the weighing chamber (2).

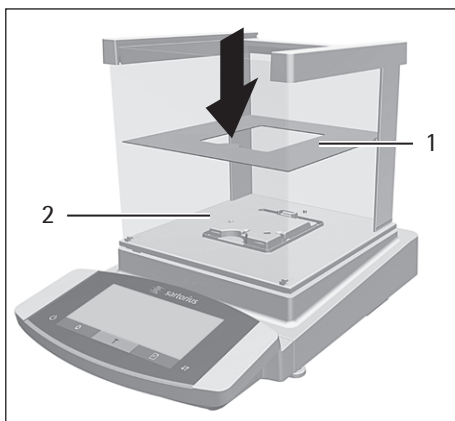

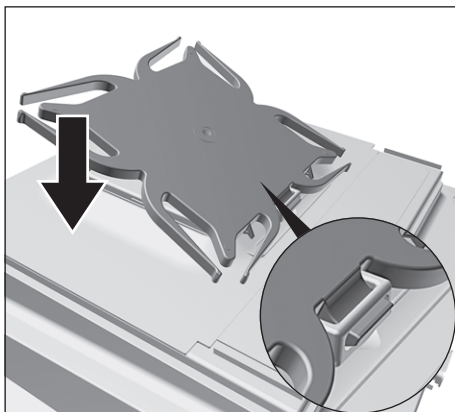

- ▶ If this relates to a device with a pan support:
 - ▶ Hook the pin on the pan support into the clip on the pan retainer.
 - ▶ Push the pan support down onto the pan retainer until the pan support lies parallel to the device housing.

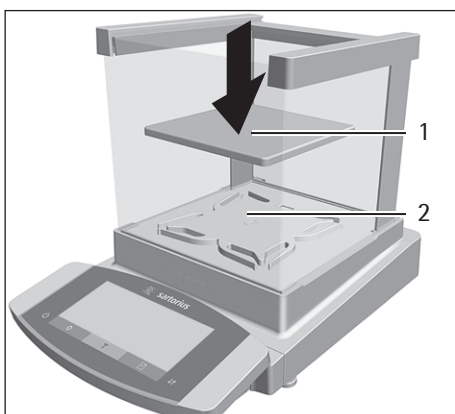

- ▶ Place the weighing pan (1) onto the pan support (2).

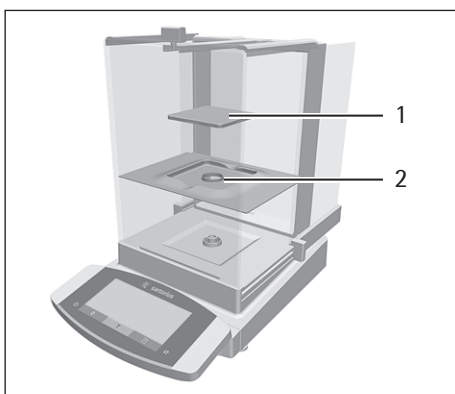

- ▶ If this relates to a device without a pan support: Place the shield plate (2) into the weighing chamber. Place the weighing pan (1) into the recess in the shield plate.

5.6.2 Installing the Analytical Draft Shield

Procedure

- ▶ Slide the upper panel into the guide rail (1).
- ▶ To fully insert the upper panel: Gently push the upper panel down.
- ▶ Slide the upper panel completely into the guide rail.

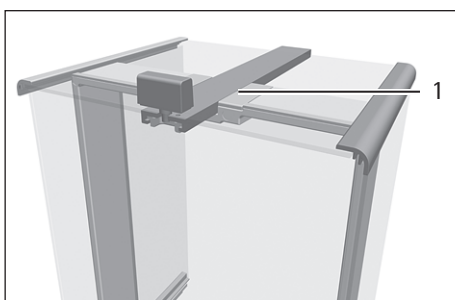

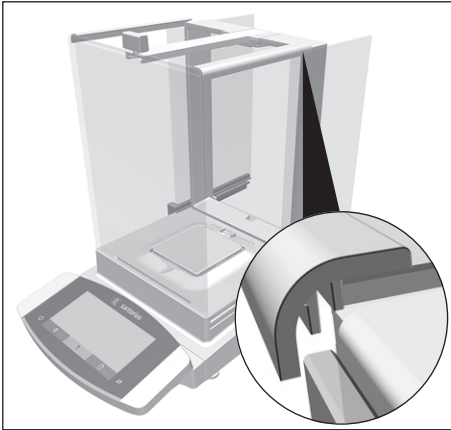

- ▶ Insert the side panels completely into the guide rails.

5.6.3 Installing the Flat Glass Draft Shield

Procedure

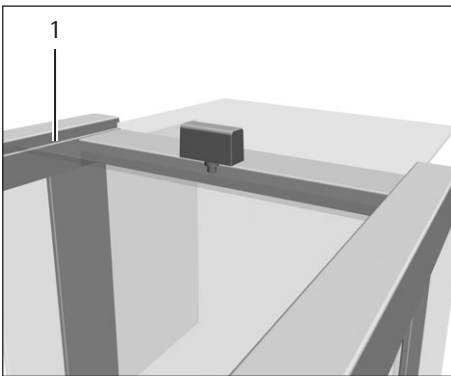

- ▶ To slide the upper panel into the slot (1): Gently tilt the upper panel down.
- ▶ Slide the upper panel completely into the slot.

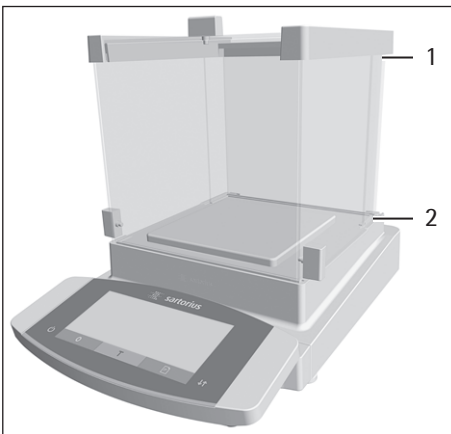

- ▶ Insert the side panel completely into the guide rails on the weighing module (2) and into the upper guide rails (1).

5.7 Installing a Device with a Frame Draft Shield

5.7.1 Positioning the Weighing Pan and Associated Components

Procedure

- ▶ Insert the pin on the pan support into the clip on the pan retainer.
- ▶ Push the pan support down onto the pan retainer until the pan support lies parallel to the device housing.

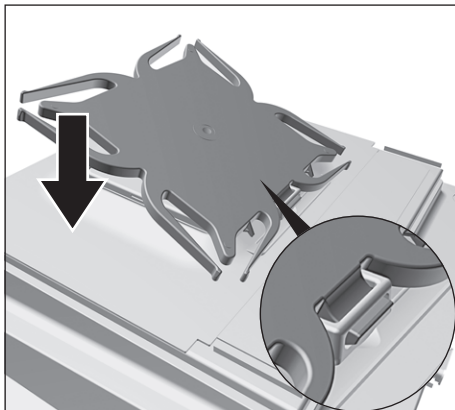

- ▶ Place the shield plate (3) on the device housing.
- ▶ Place the weighing pan (2) on the pan support.
- ▶ Place the frame draft shield (1) on the shield plate (3).

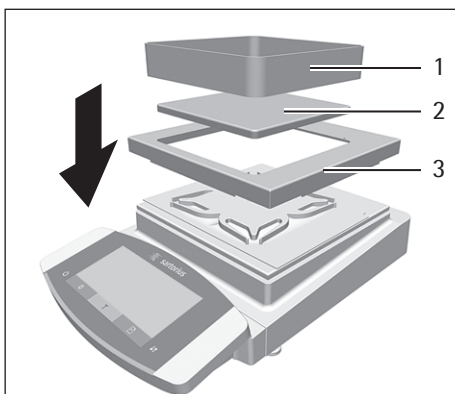

5.8 Connecting the Electronics Module (Only for Semi-microbalance)

Procedure

- ▶ Connect the connection cable to the electronics module's weighing module connection.
- ▶ Connect the other end of the connection cable to the weighing module's electronics module connection.
- ▶ To lock the connection cable: Lock the plugs of the connection cable onto both connections with two clicks in each case.
- ▶ **NOTICE** Damage to the device due to incorrect connection!
 - ▶ Check the correct fit of the plug contacts.
 - ▶ There should be **no** tension on the connection cable, e.g. do **not** install directly against a wall.



5.9 Setting Up the Cable Entry (Only for a Device with a Manual Analytical Draft Shield)

For models with a manual analytical draft shield, a cable can be fed into the weighing chamber, e.g. when using a temperature sensor.

Procedure

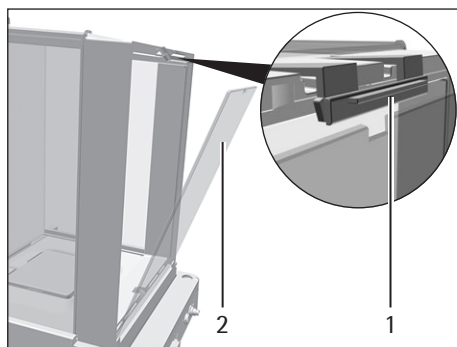

- ▶ Lift the locking tab (1) on the rear panel of the device.
- ▶ Lift the panel (2) out of the device.

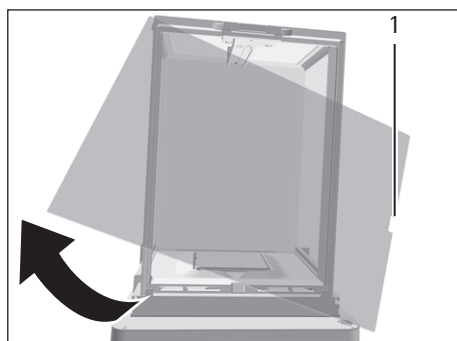

- ▶ Rotate the panel 180° so that the recess (1) in the panel points towards the weighing module.

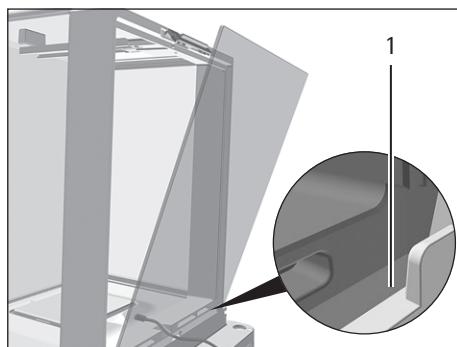

- ▶ Feed the connection cable into the weighing chamber.
- ▶ Insert the panel into the guide groove (1).

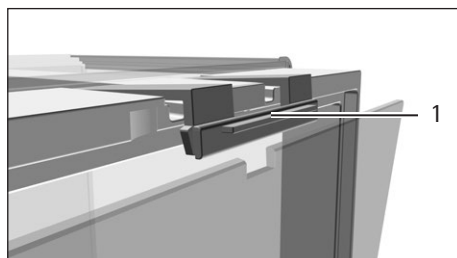

- ▶ Lift the locking tab (1) on the rear panel of the device and push down the panel.
- ▶ Press the locking tab down and close it.

5.10 Acclimatization

When a cold device is brought into a warmer area: The temperature difference can lead to condensation of humidity in the device (moisture formation). Moisture in the device can lead to malfunctions.

- ▶ Allow the device to acclimatize for approx. 2 hours at the installation site. Ensure that the device is disconnected from the power supply during that time.

6 Getting Started

6.1 Connecting Electronic Components

Procedure

- ▶ **NOTICE** Improper connection may damage the device! If the device is connected using electronic components, e.g. printer, PC: The device must be disconnected from the power supply. Ensure that the device is disconnected from the power supply.
- ▶ Connect the device using electronic components (see electronic components instructions).

6.2 Installing the AC Adapter

Procedure

- ▶ If this relates to a device without an electronics module: Plug the DC supply cable of the AC adapter into the device's "power supply" connection socket and tighten the threaded fitting.
- ▶ If this relates to a device with an electronics module: Plug the DC supply cable of the AC adapter into the electronics module's "power supply" connection socket and tighten the threaded fitting.
- ▶ Connect the power supply cable to the AC adapter connection.

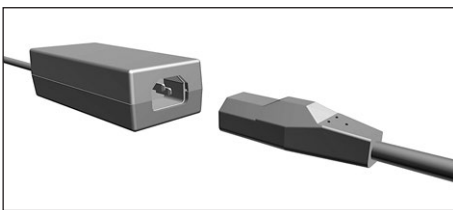
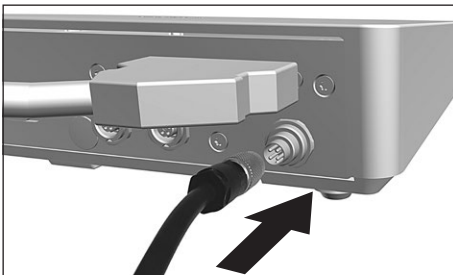
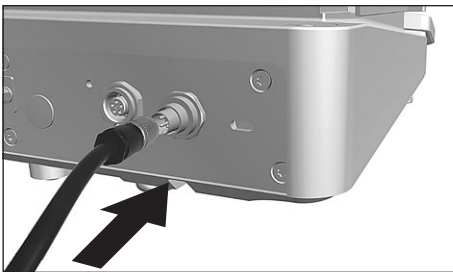

6.3 Connecting the Power Supply

Procedure

- ▶ **⚠ WARNING** Severe injuries caused by using a defective power supply cable! Check the power supply cable for damage, e.g., cracks in the insulation.
 - ▶ If required: Contact Sartorius Service.
- ▶ Check whether the country-specific power plug matches the power connections at the installation site.
 - ▶ If required: Contact Sartorius Service.
- ▶ **NOTICE** Damage to the device due to excessive input voltage! Check whether the voltage specifications on the AC adapter match those of the power supply at the installation site.
 - ▶ If the input voltage is too high: Do **not** connect the device to the power supply.
 - ▶ Contact Sartorius Service.
- ▶ Connect the mains plug of the power supply cable to the wall outlet at the installation site.
- ▷ The [BOOTING] display appears in the operating display.
- ▷ The device performs a self-test.
- ▷ The device performs an initial tare function.

7 System Settings

7.1 Performing System Settings

Default settings can be adjusted for the device and the applications in order to align with the ambient conditions and individual operating requirements.

The following settings are necessary to operate the device together with connected components:

- Set up the communication of the connected devices
- Set up additional components

The following settings are recommended to set up the device:

- Set the menu language
- Set the behavior of the isoCAL function
- Set the behavior of the motorized draft shield (only for devices with a motorized draft shield)

Procedure

- ▶ Press the [Menu] button.
- ▶ Open the desired settings menu.
- ▶ To adjust settings: Open the desired main menu and submenu.
- ▶ Select and confirm the desired configuration value (configuration values, see Chapter "7.3 Parameter List", page 37).
- ▶ Exit the menu.
- ▷ If settings have been adjusted in the "SETUP", "DEVICE", "DATA.OUTPUT" or "APPLIC." menu: The [BOOTING] display appears in the operating display and the device restarts.

7.2 Switching Off the isoCAL Function

M

If the isoCAL function is switched off for a conformity-assessed device, the device can only be used for legal-for-trade applications in restricted temperature ranges (see Chapter "15.6.2 Ambient Temperature for the isoCAL Function", page 70). The isoCAL function cannot be switched off for all model versions.

Procedure

- ▶ In the "SETUP"/"BALANCE" menu, for the "ISOCAL" parameter, select the "OFF" configuration value.

7.3 Parameter List

7.3.1 Parameters in the "Setup" Main Menu

Parameters in the "Balance" Submenu

| Parameters | Setting values | Explanation |
|------------|----------------|--|
| AMBIENT | V.STABLE | Sets the ambient conditions to "very stable": Activates a fast change in the weight values in the event of a load change with a high output rate. Recommended for the following work environment: <ul style="list-style-type: none"> – Very stable table near the wall – Closed and calm room |
| | STABLE* | Sets the ambient conditions to "stable". Recommended for the following work environment: <ul style="list-style-type: none"> – Stable table – Slight movement in the room – Slight draft |
| | UNSTABL. | Sets the ambient conditions to "unstable": Activates the delayed change in weight values with a reduced output rate. Recommended for the following work environment: <ul style="list-style-type: none"> – Simple office desk – Room with moving machinery or personnel – Slight air movement |
| | V.UNSTBL. | Sets the ambient conditions to "very unstable": Activates a significantly delayed change in the weight values and long wait for stability with a further reduction in the output rate. Recommended for the following work environment: <ul style="list-style-type: none"> – Noticeable and slow floor vibrations – Noticeable building vibrations – Weighed goods moved – Very strong air movements |
| APP FILT. | FINAL.RD.* | Activates a filter that enables a fast change in the display for very fast load changes. Display changes with minimal load changes (in the digit range) occur more slowly. |
| | FILLING | Activates a filter that enables a very fast change in the display with minimal load changes (e.g. when filling containers). |
| | REDUC. | Activates a weak but fast filter that always behaves in the same way for load changes (e.g. when filling automated systems). |
| | OFF | Deactivates the active application filter. |
| STABIL. | MAX ACC. | Sets the stability to "maximum accuracy". |
| | V. ACC. | Sets the stability to "very accurate". |
| | ACC.* | Sets the stability to "accurate". |
| | FAST | Sets the stability to "fast". |
| | V. FAST | Sets the stability to "very fast". |
| | MAX.SPEED | Sets the stability to "maximum speed". |

* Factory setting

| Parameters | Setting values | Explanation |
|------------|---|--|
| ST.DEL. | NONE | Sets the stability delay to "none": The stability symbol is displayed after the stability criterion is reached. |
| | SHORT* | Sets the stability delay to "short": The stability symbol only appears after a short delay in order to provide a reliable result despite fluctuations. |
| | MEDIUM | Sets the stability delay to "medium": The stability symbol only appears after a longer delay in order to provide a reliable result in case of higher fluctuations. |
| | LONG | Sets the stability delay to "long": The stability symbol only appears after a long delay in order to balance out major instability. |
| ZERO/TAR. | W/O STB. | Without stability: The function of the [Zero] or [Tare] key is executed immediately once the key is pressed. |
| | W/ STAB.* | With stability: The function of the [Zero] or [Tare] key is only executed after stability is achieved. |
| | AT STAB. | At stability: The function of the [Zero] or [Tare] key is executed if stability exists when the key is pressed. |
| AUTOZER. | ON* | Activates automatic zeroing. The display is automatically set to zero in case of a deviation of 0 less than (X). |
| | OFF | Deactivates automatic zeroing. Zeroing must be triggered with the [Zero] key. |
| UNIT | | The availability of units may depend on national legislation and is therefore country-specific. |
| | GRAMS* | The device displays the weight in grams. |
| | KILOGR. | The device displays the weight in kilograms (not for semi-microbalances). |
| | CARATS | The device displays the weight in carats. |
| | POUNDS | The device displays the weight in pounds (not for semi-microbalances). |
| | OUNCES | The device displays the weight in ounces. |
| | TROY OZ. | The device displays the weight in troy ounces. |
| | HKTAEL | The device displays the weight in taels (Hong Kong). |
| | SNGTAE | The device displays the weight in taels (Singapore). |
| | TWNTAE | The device displays the weight in taels (Taiwan). |
| | GRAINS | The device displays the weight in grains. |
| | PENYWT. | The device displays the weight in pennyweights. |
| | MILLIGR. | The device displays the weight in milligrams. |
| | CHINATAEL | The device displays the weight in taels (China). |
| | MOMMES | The device displays the weight in mommes. |
| | TOLA | The device displays the weight in tolas. |
| | BAHT | The device displays the weight in baht. |
| MESGHAL | The device displays the weight in mesghals. | |
| NEWTON | The device displays the weight in newtons. | |
| DISP.DIG. | ALL* | "Show all decimal places": All decimal places are shown in the display. Not available on conformity-assessed devices. |
| | LP.ON/OFF | "Reduced by 1 decimal place for load change": The last decimal place on the display is switched off until stability is achieved. |
| | DIVIS. 1 | "Last decimal place of the 1st division": The last decimal place always shows the 1st division. |
| | MINUS 1 | "Last decimal place off": The last decimal place is switched off. |

* Factory setting

| Parameters | Setting values | Explanation |
|------------|--|--|
| CAL./ADJ. | EXT.CAL. | The [Adjust] button starts an external calibration with the preset calibration weight. |
| | E.CAL.USR. | The [Adjust] button starts an external calibration with the user-defined calibration weight value. |
| | INT.CAL.* | The [Adjust] button starts an internal calibration. |
| | INT.LIN. | The [Adjust] button linearizes the balance with the integrated weight (not for precision balance) |
| CAL.SEQ. | ADJUST* | Calibration and adjustment is one routine. |
| | CAL.-ADJ. | Adjustment must be started or exited manually after calibration with the [Adjust] button. |
| ON Z/T | ON* | Activates the initial taring/zeroing. The device is tared or zeroed after it is switched on. |
| | OFF | Deactivates the initial taring/zeroing: After it is switched on, the device shows the value before it was last switched off. |
| ISOCAL | OFF | Switches the isoCAL function off. |
| | NOTE TO | The [isoCAL] button flashes if the balance needs to be adjusted. The isoCAL function must be manually triggered with the [Adjust] button. |
| | ON* | Activates the isoCAL function. The device is automatically adjusted as soon as a trigger starts the isoCAL function. |
| | ON W/LIN. (only for semi-microbalances and analytical balances) | Activates the isoCAL and linearization function. The device is automatically adjusted and then linearized as soon as a trigger starts the isoCAL function. |
| CAL.UNIT | GRAMS* | Changes the calibration weight unit to grams. |
| | KILOGR. | Changes the calibration weight unit to kilograms. |

* Factory setting

Parameters in the "General Services" Submenu

| Parameters | Setting values | Explanation |
|------------|----------------|---|
| MEN.RESET | YES | Resets the system settings to the factory default settings. |
| | NO* | Deactivates the option of resetting the device menu. |

* Factory setting

7.3.2 Parameters in the "Device" Main Menu

Parameters in the "Extras" Submenu

| Parameters | Setting values | Explanation |
|------------|----------------|--|
| MENU | EDITABLE* | Activates write access: The menu parameters can be changed. |
| | RD.ONLY | Activates read access: The menu parameters cannot be changed. |
| SIGNAL | OFF | Switches the acoustic signal off. |
| | QUIET | Sets the volume of the acoustic signal to "quiet". |
| | MEDIUM* | Sets the volume of the acoustic signal to "medium". |
| | LOUD | Sets the volume of the acoustic signal to "loud". |
| KEYS | UNLOCKED* | Deactivates the key lock. |
| | LOCKED | Activates the key lock. |

* Factory setting

| Parameters | Setting values | Explanation |
|------------|----------------|--|
| ON MODE | ON/STDBY* | The [On/Off] key switches between on/standby. |
| | ON/OFF | The [On/Off] key switches between on/off. |
| | AUTO ON | Changes the function of the [On/Off] key: The device no longer switches off or to standby mode, instead it starts a boot process. |
| LIGHTING | OFF | Deactivates the lighting on the operating display. |
| | ON* | Activates the lighting on the operating display. |

* Factory setting

Parameters in the "Draft Shield" Submenu (Only for Devices with a Motorized Draft Shield)

| Parameters | Setting values | Explanation |
|------------|----------------|--|
| CONTROL | OFF | Deactivates the motorized draft shield. |
| | ON* | Activates the motorized draft shield. |
| IONIZER | OFF* | Deactivates the ionizer. |
| | ON | Closing the draft shield activates the ionizer. |
| INT.ADJ. | NONE | The draft shield does not perform an action if an internal calibration/adjustment starts. |
| | CLOSE* | Draft shield closes if an internal calibration/adjustment starts. |

* Factory setting

Parameters in the "Ionizer" Submenu (Only for Devices with an Ionizer)

| Parameters | Setting values | Explanation |
|------------|----------------|---|
| POWER | OFF | Deactivates the ionizer. |
| | SOFT | Sets the intensity of the ionization process to soft. |
| | MEDIUM* | Sets the intensity of the ionization process to medium. |
| | STRONG | Sets the intensity of the ionization process to strong. |
| DURATION | 3..15 SEC | Sets the duration of the ionization process (factory setting: 8 seconds). |

* Factory setting

Parameters in the "Leveling" Submenu

| Parameters | Setting values | Explanation |
|------------|----------------|---|
| LEVEL | OFF | The device does not display messages on the status of the level. |
| | NOTE* | The [LEVELING] display flashes if the device needs to be leveled. |
| | ERR.MSG. | The [LEVEL.ERR.] message appears in the operating display if the device has not been leveled. |
| START | KEY | Sets the trigger for leveling to "key": Leveling must be started manually by pressing the [Leveling] button. |
| | AUTO* | Sets the trigger for leveling to "automatic": The device automatically performs a leveling function using the integrated sensor before every internal calibration/adjustment. |

* Factory setting

Parameters in the "Motion Sensor" Submenu

| Parameters | Setting values | Explanation |
|------------|----------------|--|
| CONTROL | OFF | Deactivates the motion sensor: No gestures are recognized. |
| | ON* | Activates the motion sensor. |
| NUM.GEST. | 2 GESTUR.* | Activates the control of functions with 2 gestures. Gestures: Left, right |
| | 4 GESTUR. | Activates the control of functions with 4 gestures. Gestures: Left, right, top, bottom |
| LEFT CMD. | PRINT* | Left command of the gesture control corresponds to the [Print] key. |
| | ZERO | Left command of the gesture control corresponds to the [Zero] key. |
| | TARE | Left command of the gesture control corresponds to the [Tare] key. |
| | IONIZER | Left command of the gesture control corresponds to the [Ionizer] key. |
| | D.SHIELD | Left command of the gesture control corresponds to the [Change] key. |
| | OPEN LFT. | Left command of the gesture control opens the left draft shield panel. |
| | OPEN RT. | Left command of the gesture control opens the right draft shield panel. |
| | OPEN TOP | Left command of the gesture control opens the upper draft shield panel. |
| | CLOSE DS. | Left command of the gesture control closes the entire draft shield. |
| | NONE | No function is assigned to the left command of the gesture control. |
| | RIGHT.CMD. | PRINT* |
| ZERO | | Right command of the gesture control corresponds to the [Zero] key. |
| TARE | | Right command of the gesture control corresponds to the [Tare] key. |
| IONIZER | | Right command of the gesture control corresponds to the [Ionizer] key. |
| D.SHIELD | | Right command of the gesture control corresponds to the [Change] key. |
| OPEN LFT. | | Right command of the gesture control opens the left draft shield panel. |
| OPEN RT. | | Right command of the gesture control opens the right draft shield panel. |
| OPEN TOP | | Right command of the gesture control opens the upper draft shield panel. |
| CLOSE DS. | | Right command of the gesture control closes the entire draft shield. |
| NONE | | No function is assigned to the right command of the gesture control. |
| UP.CMD. | | PRINT* |
| | ZERO | Upper command of the gesture control corresponds to the [Zero] key. |
| | TARE | Upper command of the gesture control corresponds to the [Tare] key. |
| | IONIZER | Upper command of the gesture control corresponds to the [Ionizer] key. |
| | D.SHIELD | Upper command of the gesture control corresponds to the [Change] key. |
| | OPEN LFT. | Upper command of the gesture control opens the left draft shield panel. |
| | OPEN RT. | Upper command of the gesture control opens the right draft shield panel. |
| | OPEN TOP | Upper command of the gesture control opens the upper draft shield panel. |
| | CLOSE DS. | Upper command of the gesture control closes the entire draft shield. |
| | NONE | No function is assigned to the upper command of the gesture control. |
| | DOWN.CMD. | PRINT* |
| ZERO | | Lower command of the gesture control corresponds to the [Zero] key. |
| TARE | | Lower command of the gesture control corresponds to the [Tare] key. |
| IONIZER | | Lower command of the gesture control corresponds to the [Ionizer] key. |
| D.SHIELD | | Lower command of the gesture control corresponds to the [Change] key. |
| OPEN LFT. | | Lower command of the gesture control opens the left draft shield panel. |
| OPEN RT. | | Lower command of the gesture control opens the right draft shield panel. |
| OPEN TOP | | Lower command of the gesture control opens the upper draft shield panel. |
| CLOSE DS. | | Lower command of the gesture control closes the entire draft shield. |
| NONE | | No function is assigned to the lower command of the gesture control. |

* Factory setting

Parameters in the "COM-RS232" Submenu

| Parameters | Setting values | Explanations |
|------------|----------------|--|
| DAT.REC. | SBI.WEIGH. | Enables a faster SBI communication, only for software commands to the weighing module. |
| | XBPI | Extended range of commands to control numerous balance functions with binary protocol for direct communication with the weighing module. |
| | SBI* | Enables SBI communication. The data is output to a PC or control unit. Enables the use of ESC commands from a PC to control the basic balance functions with ASCII protocol. |
| | OFF | Deactivates the automatic data output. |
| BAUD | 600 | Sets the baud rate to 600 baud. |
| | 1200 | Sets the baud rate to 1200 baud. |
| | 2400 | Sets the baud rate to 2400 baud. |
| | 4800 | Sets the baud rate to 4800 baud. |
| | 9600* | Sets the baud rate to 9600 baud. |
| | 19200 | Sets the baud rate to 19200 baud. |
| | 38400 | Sets the baud rate to 38400 baud. |
| | 57600 | Sets the baud rate to 57600 baud. |
| | 115200 | Sets the baud rate to 115200 baud. |
| PARITY | ODD* | Applies an odd parity. |
| | EVEN | Applies an even parity. |
| | NONE | Does not apply a parity. |
| STOPBIT | 1 BIT* | Sets the number of stop bits to 1. |
| | 2 BITS | Sets the number of stop bits to 2. |
| HANDSHK. | SOFTWARE | Sets the handshake protocol to software handshake. |
| | HARDWARE* | Sets the handshake protocol to hardware handshake. |
| | NONE | Does not set a handshake protocol. |
| DATABIT | 7 BITS | Sets the number of data bits to 7. |
| | 8 BITS* | Sets the number of data bits to 8. |

* Factory setting

Parameters in the "PC-USB" Submenu

| Parameters | Setting values | Explanations |
|------------|----------------|--|
| DAT.REC. | SBI.WEIGH. | Enables a faster SBI communication, only for software commands to the weighing module. |
| | XBPI | Extended range of commands to control numerous balance functions with binary protocol for direct communication with the weighing module. |
| | SBI* | Enables SBI communication. The data is output to a PC or control unit. Enables the use of ESC commands from a PC to control the basic balance functions with ASCII protocol. |
| | PC.SPREAD. | Enables data output to a spreadsheet program via a direct PC connection. |
| | PC.TEXT | Enables a direct PC connection to be established to a text processing program. |
| | OFF | Deactivates the data output. |
| | BAUD | 600 |
| 1200 | | Sets the baud rate to 1200 baud. |
| 2400 | | Sets the baud rate to 2400 baud. |
| 4800 | | Sets the baud rate to 4800 baud. |
| 9600* | | Sets the baud rate to 9600 baud. |
| 19200 | | Sets the baud rate to 19200 baud. |
| 38400 | | Sets the baud rate to 38400 baud. |
| 57600 | | Sets the baud rate to 57600 baud. |
| 115200 | | Sets the baud rate to 115200 baud. |
| PARITY | ODD* | Applies an odd parity. |
| | EVEN | Applies an even parity. |
| | NONE | Does not apply a parity. |
| STOPBIT | 1 BIT* | Sets the number of stop bits to 1. |
| | 2 BITS | Sets the number of stop bits to 2. |
| HANDSHK. | SOFTWARE | Sets the handshake protocol to software handshake. |
| | HARDWARE | Sets the handshake protocol to hardware handshake. |
| | NONE* | Does not set a handshake protocol. |
| DATABIT | 7 BITS | Sets the number of data bits to 7. |
| | 8 BITS* | Sets the number of data bits to 8. |

* Factory setting

Parameters in the "USB" Submenu

| Parameters | Setting values | Explanation |
|------------|----------------------|---|
| DEV.USED | NONE* | Indicates that no device connection is detected at the USB port. |
| | [Device Designation] | Displays the designation of the devices connected to the USB port. |

* Factory setting

7.3.3 Parameters in the "Data Output" Main Menu

Parameters in the "SBI Communication" Submenu

| Parameters | Setting values | Explanations |
|------------|----------------|---|
| COM. OUTP. | IND.NO* | Starts the data output after pressing the key or software command as an individual value without stability. |
| | IND.AFTER | Starts the data output after pressing the key or software command as an individual value after stability. |
| | IND.AT | Starts the data output after pressing the key or software command as an individual value at stability. |
| | AUTO W/O | Activates the automatic data output without stability. |
| | AUTO W/ | Activates the automatic data output after stability. |
| STOP.AUTO | OFF* | Deactivates the option to abort the automatic data output. |
| | ON | The automatic data output is aborted by pressing the [PRINT] key or a software command. |
| AUTO.CYCL. | EACH VAL* | Starts the automatic data output with a cycle after each value. |
| | 2. VALUE | Starts the automatic data output with a cycle after every 2nd value. |
| FORMAT | 22 CHARS | Data output provides 22 characters per line (16 characters for the measured values and 6 characters for identifiers). |
| | EXTR.LINE | Data output provides an additional line with the date, time, and weight value. |
| AUTO.TARE | OFF* | Deactivates automatic taring after data output. |
| | ON | The device automatically tares after data output. |

* Factory setting

Parameters in the "Settings for Printouts" Submenu

| Parameters | Setting values | Explanation |
|------------|----------------|--|
| ACTIVATE | MAN. NO | Manual without stability: Print process can be started manually at any time. |
| | MAN.AFTER* | Manual after stability: After pressing the [Print] key, the print command is only executed once stability is achieved. |
| | MAN.AT | Manual at stability: Print process can be started manually when stability is achieved. |
| | AUTO.LC | Automatically at load change: Print process starts after every load change. |
| FORMAT | 16 CHARS | Printer output prints 16 characters per line. |
| | 22 CHARS* | Printer output prints 22 characters per line (16 characters for the measured values and 6 characters for identifiers) |
| | EXTR.LINE | Printer output prints an additional line with the date, time, and weight value. |
| PRINT.INIT | OFF | Deactivates the output of the application parameters. |
| | ALL* | Print command prints all parameters. |
| | MAIN PAR. | Print command only prints the main parameters. |
| GLP | OFF* | Deactivates the GLP printout. |
| | CAL.-ADJ. | Activates the GLP printout for all calibration and adjustment processes. |
| | ALWAYS | The GLP printout is always switched on. All printouts contain a GLP header and a GLP footer. |
| TAR./PRT. | OFF* | Deactivates automatic taring after printer output. |
| | ON | Automatically tares the device after every printout. |
| TIME | 24H | Sets the time to 24-hour mode. |
| | 12H | Sets the time to 12-hour mode (AM/PM). |

* Factory setting

| Parameters | Setting values | Explanation |
|------------|----------------|---|
| DATE | DD.MMM.YY* | Sets the date display format to DD.MMM.YY |
| | MMM.DD.YY | Sets the date display format to MMM.DD.YY |

* Factory setting

Parameters in the "PC Direct Transfer" Submenu

| Parameters | Setting values | Explanations |
|------------|----------------|--------------------------------------|
| DEC.SEPAR. | DEC.POINT* | Sets a point as a decimal separator. |
| | DEC.COMMA | Sets a comma as a decimal separator. |
| OUTP.FORM. | TEXT+NUM.* | Exports text and numbers. |
| | ONLY NUM. | Only exports numbers. |

* Factory setting

7.3.4 Parameters in the "Applications" Main Menu

Parameters in the "Weighing" Submenu

| Parameters | Setting values | Explanation |
|------------|----------------|---|
| UNIT | OFF | Deactivates the "Toggle between weight units" function. |
| | ON* | Activates the "Toggle between weight units" function. |

* Factory setting

Parameters in the "Counting" Submenu

| Parameters | Setting values | Explanation |
|------------|----------------|--|
| RESOLUT. | DISP.ACC.* | Sets the resolution to "display resolution". The "Counting" application is started with the displayed value. |
| | 10-FOLD | Sets the resolution to 10-times more accurate than "display resolution". |
| | 100-FOLD | Sets the resolution to 100-times more accurate than "display resolution". |
| REF.UPDT. | OFF* | Deactivates automatic reference sample updating. |
| | AUTO | Activates the automatic reference sample updating. |

* Factory setting

Parameters in the "Weighing in Percent" Submenu

| Parameters | Setting values | Explanation |
|------------|----------------|--|
| DEC.PLCS | NONE | The result of the "Weighing in Percent" application is displayed without decimal places. |
| | 1 DEC.PL.* | The result of the "Weighing in Percent" application is displayed to 1 decimal place. |
| | 2 DEC.PL. | The result of the "Weighing in Percent" application is displayed to 2 decimal places. |
| | 3 DEC.PL. | The result of the "Weighing in Percent" application is displayed to 3 decimal places. |

* Factory setting

Parameters in the "Net-Total" Submenu

| Parameters | Setting values | Explanation |
|------------|----------------|-------------------------------------|
| COMP.PRT. | OFF | Deactivates the component printout. |
| | ON* | Activates the component printout. |

* Factory setting

Parameters in the "Totalizing" Submenu

| Parameters | Setting values | Explanation |
|------------|----------------|-------------------------------------|
| COMP.PRT. | OFF | Deactivates the component printout. |
| | ON* | Activates the component printout. |

* Factory setting

Parameters in the "Animal Weighing" Submenu

| Parameters | Setting values | Explanation |
|------------|----------------|--|
| ACTIVITY | CALM | Sets the intensity of the "Animal activity" to "calm". Recommended for minor movements of the sample, e.g. caused by placement on the weighing pan. |
| | MEDIUM* | Sets the intensity of the "Animal activity" to "medium". Recommended for medium movements of the sample, e.g. caused by placement on the weighing pan. |
| | V.ACTIVE | Sets the intensity of the "Animal activity" to "very active". Recommended for very active movements of the sample, e.g. caused by placement on the weighing pan. |
| START | MANUAL | The "Animal weighing" application must be manually selected in the start screen. |
| | AUTO* | Sets the trigger to start the "Animal weighing" application to "automatic". |

* Factory setting

Parameters in the "Calculation" Submenu

| Parameters | Setting values | Explanation |
|------------|----------------|--|
| METHOD | MUL.* | Specifies multiplication as the method of calculation for the "Calculation" application. |
| | DIV. | Specifies division as the method of calculation for the "Calculation" application. |
| DEC.PLCS | NONE | The result of the "Calculation" application is displayed without decimal places. |
| | 1 DEC.PL.* | The result of the "Calculation" application is displayed to 1 decimal place. |
| | 2 DEC.PL. | The result of the "Calculation" application is displayed to 2 decimal places. |
| | 3 DEC.PL. | The result of the "Calculation" application is displayed to 3 decimal places. |

* Factory setting

Parameters in the "Density Determination" Submenu

| Parameters | Setting values | Explanation |
|------------|----------------|--|
| DEC.PLCS | NONE | The result of the "Density determination" application is displayed without decimal places. |
| | 1 DEC.PL.* | The result of the "Density determination" application is displayed to 1 decimal place. |
| | 2 DEC.PL. | The result of the "Density determination" application is displayed to 2 decimal places. |
| | 3 DEC.PL. | The result of the "Density determination" application is displayed to 3 decimal places. |

* Factory setting

Parameters in the "Statistics" Submenu

| Parameters | Setting values | Explanation |
|------------|----------------|--|
| COMP.PRT. | OFF | Deactivates the component printout. |
| | ON* | Activates the component printout. |
| TAR./STAT. | OFF* | Deactivates automatic taring after the components are saved. |
| | ON | Activates automatic taring after the components are saved. |

* Factory setting

7.3.5 Parameters in the "Input" Main Menu

| Parameters | Setting values | Explanation |
|------------|---|--|
| ID NO. | Maximum of 8 characters 09-0, A-Z, - , space | Saves the entered ID number for the device. |
| LOT ID | OFF* | Deactivates the output of a line for the lot ID number for the GLP printout. |
| | ON | Activates the output of a line for the lot ID number for the GLP printout. |
| DATE | | Saves the entered date. |
| TIME | | Saves the entered time. |
| USER.PASS. | Maximum of 8 characters 09-0, A-Z, - , space | Saves the entered user password. |
| DEL.PASS. | YES | Deletes the entered user password. |
| | NO* | Does not delete the entered user password. |
| SERV.PASS. | Maximum of 8 characters 09-0, A-Z, - , space | Activates service mode. |
| CAL.WT. | | Changes the calibration weight for the adjustment or calibration process with the user-defined weight value. |

* Factory setting

7.3.6 Parameters in the "Language" Main Menu

| Parameters | Setting values | Explanation |
|------------|----------------|-------------|
| Language | ENGLISH* | English |
| | DEUTSCH | German |
| | FRANCAIS | French |
| | ITALIANO | Italian |
| | ESPANOL | Spanish |
| | PORTUG. | Portuguese |
| | PYCKИИ | Russian |
| | POLSKI | Polish |

* Factory setting

7.3.7 Parameters in the "Unit 1", "Unit 2", "Unit 3", and "Unit 4" Application Menus

| Parameters | Setting values | Explanation |
|----------------|----------------|---|
| NONE* | | The availability of units may depend on national legislation and is therefore country-specific. |
| | | Switches the toggle between weight units off for this position. |
| GRAMS – NEWTON | NONE* | The configuration values for the [DISP.DIG.] parameter in the [BALANCE] menu are saved for the scale interval ([DISP.DIG.] parameter see Chapter 7.3.1, page 37). |
| | ALL | "Show all decimal places": All decimal places are shown in the display. |
| | LP.ON/OFF | "Reduced by 1 decimal place for load change": The last decimal place on the display is switched off until stability is achieved. |
| | DIVIS. 1 | "Last decimal place of the 1st division": The last decimal place always shows the 1st division. |
| | MINUS 1 | "Last decimal place off": The last decimal place is switched off and the measured value is rounded up or down by one decimal place. |

* Factory setting

8 Operation

8.1 Switching the Device On and Off

The device only delivers accurate values if it has reached the necessary operating temperature. The warm-up time after switching the device on must therefore be complied with.

Procedure

- ▶ Connect the device to the power supply.
 - ▶ If the device does not switch on automatically after it is connected to the power supply: Press the on key on the weighing module.
 - ▶ To allow the device to reach the necessary operating temperature to accurately determine the weight: Comply with the warm-up time of 2 hours after switching the device on.
- M
- ▷ If this relates to a conformity-assessed device: The weight value is marked as invalid during the warm-up period.
 - ▶ Level and adjust the device.
 - ▷ The device is ready for use.
 - ▶ **NOTICE** Pointed or sharp-edged objects may damage the operating display! Touching the operating display with objects, such as pens, may damage the touchscreen surface of the operating display. Only touch the operating display with your fingertips.
 - ▶ To switch the device off: Press and hold the [On / Off] key.

8.2 Leveling the Device

The inclination sensor detects inclines in the alignment of the device. If leveling is necessary: The [Leveling] display flashes.

Procedure

- ▶ Press the [Leveling] button.
- ▷ The [Leveling] display flashes
- ▷ The device levels itself automatically using the motorized leveling feet.

8.3 Opening and Closing the Motorized Draft Shield (Only for Devices with a Motorized Draft Shield)

Pressing the [Change] key enables the motorized side and upper draft shield panels to be opened and closed. The [Change] key can be used to control up to three doors simultaneously.

Procedure

- ▶ Switch on the device.
- ▶ Close all draft shield doors.
- ▶ To determine how far a door is opened by pressing the [Change] key: Manually push the door open to the desired position.
- ▶ If several doors are to be controlled by the [Change] key simultaneously: Manually push the desired doors open to the desired position.
- ▶ Press the [Change] key.
- ▷ The opened door is closed.
- ▷ If several doors are open: All open doors are closed.
- ▷ When the [Change] key is next pressed, the door is opened or closed.

8.4 Preparing Weighings

The device must be prepared before every weighing.

Requirements

The device is ready for use

NOTICE

Chemicals may damage the device or accessories!

Chemicals can attack the device or the connected accessories internally and externally. This may damage the device and accessories.

- ▶ Use appropriate containers when weighing chemicals.
-

Procedure

- ▶ Level the device.
- ▶ Zero the device for calibration. To do so, press the [Zero] key.
- ▶ If the device **cannot** be zeroed: Remove the sample to be weighed and re-zero the device.
- ▶ Calibrate the device.

8.5 Weighing

Procedure

- ▶ Zero the device.
- ▶ If necessary, place a container for the sample on the device.
- ▶ To compensate the weight of the container: Tare the device. To do so, press the [Tare] key.
- ▶ If a container is used for the sample: Place the sample in the container.
- ▶ If **no** container is used for the sample: Place the sample on the weighing pan.
- ▶ Once the weight value no longer changes and the weighing unit is displayed: Read off the measured value.

8.6 Overview of Calibration, Adjustment, and Linearization

During calibration, a calibration weight is used to determine how much the displayed value deviates from the actual value. This deviation is compared against a preset target value. The subsequent adjustment eliminates this deviation. During linearization, the deviation of the values from the ideal characteristic curve is corrected.

Calibration and adjustment must be performed regularly:

- Daily, every time the device is switched on
- After every leveling
- After changing the ambient conditions (temperature, humidity, or air pressure)
- After setting the device up at a new installation site

Calibration and adjustment may be performed in different ways:

- Adjusting with the isoCAL function
- Internal or external calibration or adjustment
- For semi-microbalances and analytical balances: Internal linearization



Only internal calibration/adjustment is possible for all conformity-assessed devices in legal metrology.

8.7 Adjusting with the isoCAL Function

The device can be automatically internally calibrated and adjusted using the isoCAL function.

Requirements

- The device is **not** located in the menu.
- Alphanumeric inputs are **not** active.
- The load on the weighing pan remains unchanged for 2 minutes.
- The load on the weighing pan amounts to no more than 2% of the maximum load.
- The device does **not** register an input for 2 minutes.

If all requirements for starting the isoCAL function are met and one of the following conditions occurs: The isoCAL function is automatically triggered.

Possible conditions are:

- The ambient temperature has changed since the last adjustment/calibration.
- The interval time was exceeded (interval time, see Chapter "15.8 Recommended Calibration Weight", page 76).
- The device has been leveled.
- The device has been disconnected from the power supply since the last adjustment/calibration (only for conformity-assessed models).

Procedure

- ▶ If the isoCAL auto-start function is set (configuration values for the "ISOCAL" parameter, see Chapter "7.3.1 Parameters in the "Setup" Main Menu", page 37):
 - ▷ If the isoCAL function is triggered according to the aforementioned conditions: The [isoCAL] button flashes in the operating display.
 - ▷ In the operating display, a time display counts down from 15 seconds to 0.
 - ▷ If **no** load change or **no** operation takes place on the device before the expiration of the time display: The isoCAL function starts.
- ▶ If the isoCAL manual start function is set (configuration values for the "ISOCAL" parameter, see Chapter "7.3.1 Parameters in the "Setup" Main Menu", page 37):
 - ▷ If the isoCAL function is triggered: The [isoCAL] button flashes in the operating display.
 - ▶ Press the [isoCAL] button.
 - ▷ The isoCAL function starts.

8.8 Internally Calibrating and Adjusting the Device

Calibration and Subsequent Adjustment

Requirements

- The weighing pan is unloaded.
- The operating display shows a stable weight value.

Procedure

- ▶ To set the internal adjustment in the menu: In the "SETUP"/"BALANCE" menu, for the "CAL./ADJ." parameter, select the "INT.CAL." configuration value.
- ▶ To set the sequence of the adjustment function to calibration and subsequent automatic adjustment: In the "SETUP"/"BALANCE" menu, for the "CAL.SEQ." parameter, select the "ADJUST" configuration value.
- ▶ Exit the menu.
- ▶ Press the [Zero] key.
- ▶ To start the internal calibration/adjustment: Press the [Adjust] button.

- ▶ If automatic leveling is set for a model with motorized adjusting feet: The device levels itself automatically.
- ▷ The internal calibration weight is loaded.
- ▷ The [CAL.RUN.] display appears in the operating display during calibration.
- ▷ The device is automatically calibrated and the internal calibration weight is removed.
- ▷ The [CAL.END] display indicates the end of calibration.

Manually Starting Adjustment after Calibration

Requirements

- The weighing pan is unloaded.
- The operating display shows a stable weight value.

Procedure

- ▶ To set the internal adjustment in the menu: In the "SETUP"/"BALANCE" menu, for the "CAL./ADJ." parameter, select the "INT.CAL." configuration value.
- ▶ To set the sequence of the adjustment function to calibration without subsequent automatic adjustment: In the "SETUP"/"BALANCE" menu, for the "CAL.SEQ." parameter, select the "CAL/ADJUST" configuration value.
- ▶ Exit the menu.
- ▶ Press the [Zero] key.
- ▶ To start the internal calibration: Press the [Adjust] button.
- ▶ If automatic leveling is set for a model with motorized adjusting feet: The device levels itself automatically.
- ▷ The internal calibration weight is loaded.
- ▷ The [CAL.RUN.] display appears in the operating display during calibration.
- ▷ The calibration weight value is shown.
- ▶ To start adjustment: Press the [Confirm] button on the keypad.
- ▷ The device is calibrated and the internal calibration weight is removed.
- ▷ The [CAL.END] display indicates the end of calibration.

8.9 Externally Calibrating and Adjusting the Device (Not for Conformity-assessed Models)

External Calibration with Factory Set Weight Value

Procedure

- ▶ In the "SETUP"/"BALANCE" menu, for the "CAL./ADJ." parameter, select the "EXT.CAL." configuration value.

Set the User-defined Weight Value

A weight value can be set for the calibration weight. This user-defined weight value is used for the external calibration.

If no user-defined weight value is set: The preset weight value is used.

Procedure

- ▶ In the "INPUT" menu, select the "CAL.WT." configuration value.
- ▶ Enter and confirm the desired weight value.
- ▶ To use the user-defined weight value for the next calibration: In the "Balance" menu, for the "CAL./ADJ." parameter, select the "E.CAL.USR." configuration value.

Calibration and Subsequent Adjustment

Requirements

- The weighing pan is unloaded.
- The operating display shows a stable weight value.
- The device is not locked against external calibration.
- Keep calibration weight ready for use.

Procedure

- ▶ To set the external calibration in the menu: In the "SETUP"/"BALANCE" menu, for the "CAL./ADJ." parameter, select external calibration with preset calibration weight or external calibration with user-defined calibration weight as described above.
- ▶ To set the sequence of the adjustment function to calibration and subsequent automatic adjustment: In the "SETUP"/"BALANCE" menu, for the "CAL.SEQ." parameter, select the "ADJUST" configuration value.
- ▶ Exit the menu.
- ▶ Press the [Zero] key.
- ▶ Press the [Adjust] button.
- ▶ If automatic leveling is set for a model with motorized adjusting feet: The device levels itself automatically.
- ▶ Place the indicated calibration weight on the balance. The device is automatically adjusted after calibration, if the calibration weight placed on the device is within the specified limits.
 - ▷ The [+] sign is shown if the applied weight is too high.
 - ▷ The [-] sign is shown if the applied weight is too low.
- ▷ The [CALEND] message indicates the end of calibration.
- ▶ Remove the calibration weight after calibration is complete.

Manually Starting Adjustment after Calibration

Requirements

- The weighing pan is unloaded.
- The operating display shows a stable weight value.
- The device is not locked against external calibration.

Procedure

- ▶ To set the external calibration in the menu: In the "SETUP"/"BALANCE" menu, for the "CAL./ADJ." parameter, select external calibration with preset calibration weight or external calibration with user-defined calibration weight as described above.
- ▶ To set the sequence of the adjustment function to calibration without subsequent automatic adjustment: In the "SETUP"/"BALANCE" menu, for the "CAL.SEQ." parameter, select the "CAL/ADJUST" configuration value.
- ▶ Exit the menu.
- ▶ Press the [Zero] key.
- ▶ Press the [Adjust] button.
- ▶ If automatic leveling is set for a model with motorized adjusting feet: The device levels itself automatically.
- ▶ Place the indicated calibration weight on the balance. The calibration can only be started, if the calibration weight used is within the defined limits.
 - ▷ The [+] sign is shown if the applied weight is too high.
 - ▷ The [-] sign is shown if the applied weight is too low.
- ▶ Press the [Confirm] button on the keypad. This starts the calibration.
- ▷ The [CALEND] display indicates the end of calibration.
- ▶ Remove the calibration weight after calibration is complete.

8.10 Printing Results

The results of the calibration can be printed in a GLP printout.

Procedure

- ▶ Set the GLP printout in the menu (setting parameters, see Chapter "Parameters in the "Settings for Printouts" Submenu", page 44):
- ▶ Calibrate the device.
- ▷ Once the calibration is complete:
 - ▷ The printing process starts.
 - ▷ The GLP footer is printed.

8.11 Weighing and Printing with ID Marking

The device and every lot can be assigned an ID number. The ID numbers are provided in the GLP header during GLP-compliant printing.

Requirements

- The ID marking is entered in the menu, e.g. "BATCH1" (see Chapter "7.3.5 Parameters in the "Input" Main Menu", page 47).
- The printing of the lot ID line in the GLP printout is activated in the menu (see Chapter "7.3.5 Parameters in the "Input" Main Menu", page 47).
- The GLP-compliant printout is activated (see Chapter "7.3.5 Parameters in the "Input" Main Menu", page 47).
- The format for the printout is set to 22 characters per line (configuration parameters, see Chapter "7.3.3 Parameters in the "Data Output" Main Menu", page 44).

Procedure

- ▶ Start the printout. To do so, press the [Print] key.
- ▶ The GLP header is printed with the ID marking set in the menu and the current weight value.
- ▶ The [GLP] button appears in the operating display.
- ▶ To exit the GLP printout: Press the [GLP] button.
- ▷ The GLP footer is printed.

```

-----
23-Apr-2018    13:06
      Sartorius
Mod.          MCE5202S
Ser. no.      12345678
Ver.   09-05-00.09.01
ID            CHARGE01
-----
L  I D
G          +   50.12 g
-----
23-Apr-2018    13:07
  
```

8.12 Turning the Ionizer On/Off (Optional)

Procedure

- ▶ To activate the ionizer in the menu and to determine the intensity at which the ionizer is to operate: In the "DEVICE"/"IONIZER" menu, for the "POWER" parameter, select the "SOFT", "MEDIUM" or "STRONG" configuration value.
- ▶ To specify the duration of the ionization process in the menu: In the "DEVICE"/"IONIZER" menu, for the "DURATION" parameter, select a value of "3 SEC" to "15 SEC".
- ▶ Exit the settings menu.
- ▷ The [Ionizer] button appears in the operating display.
- ▶ To start the ionization process: Press the [Ionizer] button.
- ▶ To switch off the ionizer in the menu: In the "DEVICE"/"IONIZER" menu, for the "POWER" parameter, select the "OFF" configuration value.

8.13 Running Applications (Examples)

8.13.1 Executing the "Toggle Between Weight Units" Function

The "Toggle between weight units" function enables a switch between the basic unit display and up to 4 other units. The units can be set during the weighing process and the decimal places can be adjusted.

The basic unit is displayed every time the device is started.

Procedure

- ▶ To activate the "Toggle between weight units" function in the menu: In the "BALANCE" menu, for the "UNIT" parameter, select the "ON" configuration value.
- ▶ Exit the settings menu.
- ▷ The device boots up.
- ▶ To select the convertible units:
 - ▶ If this relates to a device with a motorized draft shield: Press and hold down the [Toggle between weight units] button.
 - ▶ If this relates to a device without a motorized draft shield: Press and hold down the [Toggle between weight units] button of the [Change] key.
- ▶ The "Toggle between weight units" function menu opens.
- ▶ Select a submenu from "Unit 1" – "Unit 4".
- ▶ Select the desired unit and confirm the display (available units, see Chapter "7.3.7 Parameters in the "Unit 1", "Unit 2", "Unit 3", and "Unit 4" Application Menus", page 48).
- ▶ To set the number of display digits for the selected unit: Press the "Confirm" button (configuration parameters, see Chapter "7.3.7 Parameters in the "Unit 1", "Unit 2", "Unit 3", and "Unit 4" Application Menus", page 48).
- ▶ Select the desired number of display digits and confirm the selection.
- ▶ Exit the "Toggle between weight units" function menu.
- ▶ To switch the displayed mass unit during weighing or before starting an application:
 - ▶ If this relates to a device with a motorized draft shield: Press the [Toggle between weight units] button multiple times if necessary, until the desired unit is displayed.
 - ▶ If this relates to a device without a motorized draft shield: Press the [Toggle between weight units] button or the [Change] key multiple times if necessary, until the desired unit is displayed.
- ▷ The current weight value is displayed in the selected unit.

8.13.2 Running the "Statistics" Application

The "Statistics" application saves up to 99 weight values and evaluates these statistically.

The following values are saved and exported by the statistics application:

- Number of components
- Mean value
- Standard deviation
- Variation coefficient
- Sum of all values
- Lowest value (minimum)
- Highest value (maximum)
- Spread: Difference between maximum and minimum

The "Statistics" application can be combined with the following functions:

- Toggle between weight units only available before starting the application
- ID marking
- Automatic taring

Procedure

- ▶ Select the Statistics application in the "APPLIC." menu.
- ▶ Exit the settings menu.
- ▶ Place a sample on the weighing pan.
- ▶ Change the displayed weight unit if necessary.
- ▶ To start the recording of the statistics: Press the [Confirm] button on the keypad.
- ▷ The current weight value is saved.
- ▶ To save the next value:
 - ▶ Remove the sample on the weighing pan.
 - ▶ Place a new sample on the weighing pan and press the [Confirm] button.
- ▶ To switch between the display of the current weight value, the number of saved components, and the calculated mean in the results display: Press the [Up] or [Down] button.
- ▶ To print and exit the current statistics, and to delete the saved values: Press the [Back] or [GLP] button.

```

-----
Comp01+    100.22 g
  
```

```

-----
Comp02+    100.21 g
  
```

```

-----
n           6
x   +     100.258 g
s   +       0.037 g
sRel +       0.04 %
Sum  +     601.55 g
Min  +     100.21 g
Max  +     100.31 g
Diff +       0.10 g
-----
  
```

9 Cleaning and Maintenance

9.1 Preparing a Device with an Analytical Draft Shield or Flat Glass Draft Shield

Procedure

- ▶ Turn the device off.
- ▶ Disconnect the device from the power supply. To do so, disconnect the power supply cable from the wall outlet.
- ▶ Fully open the draft shield side panels and upper panel.

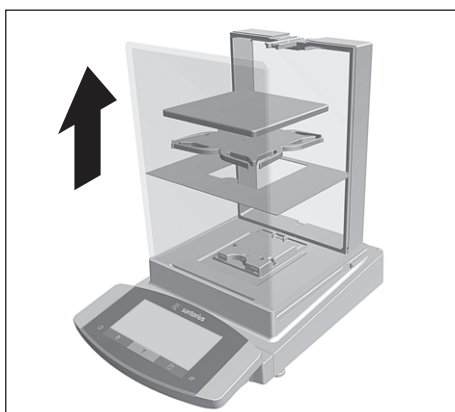
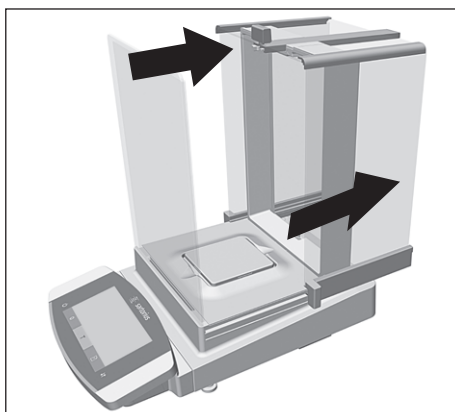

- ▶ Remove the weighing pan and all associated components from the weighing compartment, e.g. shield plate, pan support.

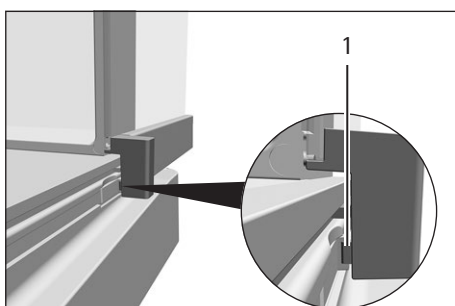

- ▶ To remove the side panels:
 - ▶ If this relates to a device with an analytical draft shield: Press and hold the locking button (1) on the door handle and pull the side panels completely out of the guide rails.

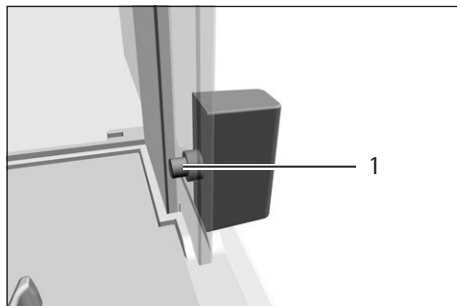

- ▶ If this relates to a device with a flat glass draft shield: Press and hold the locking button (1) on the door handle and pull the side panels completely out of the guide rails.

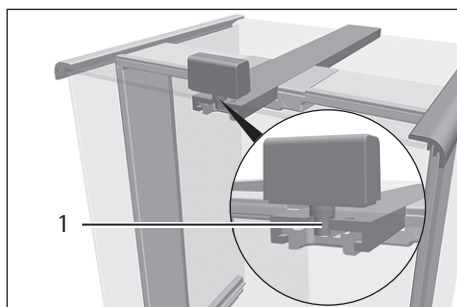

- ▶ To remove the upper panel: Press and hold the locking button (1) on the door handle and pull the upper panel completely out of the guide rails.

9.2 Preparing a Device with a Frame Draft Shield

Procedure

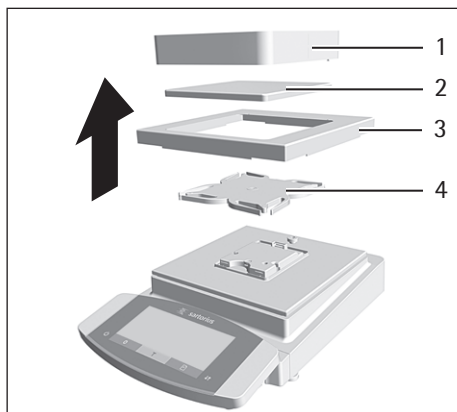

- ▶ Turn the device off.
- ▶ Disconnect the device from the power supply. To do so, disconnect the power supply cable from the wall outlet.
- ▶ Remove the frame draft shield (1) and clean it with a brush or a damp cleaning cloth.
- ▶ Remove the weighing pan (2).
- ▶ Remove the shield plate (3) and pan support (4)

9.3 Cleaning the Device

NOTICE

Corrosion or damage to the device due to unsuitable cleaning agents!

- ▶ Do **not** use corrosive, chloride-containing, or aggressive cleaning agents.
- ▶ Do **not** use cleaning agents that contain abrasive ingredients, e.g. scouring agents, steel wool.
- ▶ Do **not** use solvent-based cleaning agents.
- ▶ Check whether the cleaning agents used are compliant materials (see Chapter "15.3 Materials", page 69).
- ▶ Make sure that cleaning materials, such as cloths, are only slightly damp.

Procedure

- ▶ **NOTICE** Malfunction or damage to the device due to the ingress of moisture or dust!
 - ▶ Remove dust and powdery sample residue with a brush or hand-held vacuum cleaner.

- ▶ **NOTICE** Corrosion or damage to the weighing pan due to unsuitable cleaning agents!
 - ▶ Wipe down the balance base, the shield plate, and the weighing pan with a cleaning agent and a cloth. The cleaning agent must be suitable for stainless steel and titanium.
 - ▶ Wipe the associated components of the weighing pan with a brush or a damp cleaning cloth, e.g. shield plate, support pan.
 - ▶ Wipe the device housing with a damp cloth. For more severe contamination, use a mild soap solution.
 - ▶ If this relates to a device with an analytical draft shield or flat glass draft shield: Wipe the weighing chamber with a damp cloth. For more severe contamination, use a mild soap solution.

Tip

We recommend cleaning the weighing pan on a regular basis, e.g. weekly. Do not allow deposits to form on the weighing pan.

Protective oil may be applied to the weighing pan for additional protection. The protective oil must be suitable for stainless steel and titanium.

9.4 Assembling and Connecting the Device

Procedure

- ▶ Re-insert all components into the device (for insertion, see Chapter "5.6 Installing a Device with an Analytical Draft Shield or Flat Glass Draft Shield", page 29, Chapter "5.7 Installing a Device with a Frame Draft Shield", page 32).
- ▶ Re-connect the device to the power supply (see Chapter "6.3 Connecting the Power Supply", page 35).

9.5 Maintenance Schedule

| Interval | Component | Action | Chapter, page |
|---|---------------|---------------------------|---------------|
| Monthly to every 2 years, depending on the operating conditions | Entire system | Contact Sartorius Service | 17, 81 |

9.6 Performing a Software Update

A software update can be installed from a USB mass storage device using the device's USB-A connection.

Requirements

- The device is switched on.
- The software update is saved on a USB mass storage device.

Procedure

- ▶ Download the software update from the Sartorius website onto the USB mass storage device.
- ▶ If this relates to a zip file: Unzip the software update on the stick.
- ▶ Insert the USB mass storage device with the software update into the device's USB-A connection.
- ▶ Access the configuration menu and select the "UPDATE" main menu.
- ▶ In the "UPDATE" main menu, select the "EXECUTE?" parameter.
- ▷ The [COPYING] display appears in the operating display.
- ▷ The [REBOOT] display appears in the operating display and the device restarts.
- ▷ The [UNPACK] display appears in the operating display.
- ▷ The [RESTART] display appears in the operating display and the device restarts.
- ▷ During the restart, the [CHECK.APC] display appears first. The [PROG APC] display then appears in the operating display for about 2 minutes.
 - ▶ Do **not** switch off the device!
- ▷ The device confirms successful installation with the [PROG OK] display.
- ▷ All identified components are updated with the new firmware.
- ▷ The device confirms the end of the installation process with the [FINISH] display.
- ▷ The device restarts.
- ▷ The device is ready for use.

10 Malfunctions

10.1 Status Messages

| Status Message | Fault | Cause | Remedy | Chapter, page |
|----------------|--|--|--|---------------|
| OLDER? | If a USB mass storage device with a software update is connected: The device detects an obsolete update version. | The software update version is older than the software version on the device. | To perform the update anyway: Confirm the display. | |
| LOCKED | A software update is to be installed on a conformity-assessed device. | Software updates are not permitted for conformity-assessed devices. | If the software update has received corresponding approval: The software update can be uploaded into the device by Sartorius Service. Re-verification may then be necessary. | |
| INVALID. | If a USB mass storage device with a software update is connected: The device cannot find a valid update. | No valid manufacturer software updates exist on the connected USB mass storage device. | Check whether files exist on the USB mass storage device. Procure the software update files from Sartorius Service. | |

10.2 Warning Messages

| Warning Message | Fault | Cause | Remedy | Chapter, page |
|-----------------|---|---|---|---------------|
| APP.ERR. | The device has measured an invalid weight value. | The applied weight is too low. | Increase the applied weight to more than the minimum load. | |
| | | The weight value is negative. | | |
| | | No sample has been placed on the balance. | Place the sample on the balance. | |
| DIS.ERR. | The value to be output cannot be shown in the operating display. | The data to be displayed is not compatible with the set display format. | Adjust the display settings in the menu, e.g. resolution, unit, decimal places. | |
| HIGH | The device is overloaded. | The device's maximum weighing capacity has been exceeded | Reduce the applied weight to below the device's maximum weighing capacity. | |
| LEVEL.ERR. | The device is not measuring a weight value. | The device is not leveled. | Level the device. | 8.2, 49 |
| LOW | The modulation of the weighing converter inside the weighing module is too low. | No weighing pan has been placed on the balance. A previously forgotten weight was removed after starting the device. | Insert the weighing pan into the device and switch the device off and on again. | |
| ERR 54 | | An error exists in the weighing system or in the device electronics. | Contact Sartorius Service. | |

| Warning Message | Fault | Cause | Remedy | Chapter, page |
|--------------------|---|---|--|---------------|
| CHK.ERR. | The internal storage medium is faulty. | A memory error exists in the firmware. | Perform a software update. If the problem occurs again: Contact Sartorius Service. | 9.6, 60 |
| COMM.ERR. | The device is not receiving any weight values. | No communication exists between the control unit and the weighing module. | Wait until the control unit restores the communication with the weighing module. If the problem occurs again: Contact Sartorius Service. | |
| ELISE.ERR. | No communication with the inclination sensor. | A memory error exists in the firmware. | Switch the device off and on again. If the problem occurs again: Contact Sartorius Service. | |
| MOTOR.ERR. | The device cannot be leveled. | The device's incline is too great or a motorized foot is defective. | Change the installation site. If the problem occurs again: Contact Sartorius Service. | |
| PRT.ERR. | The [Print] key is locked. | The data interface for print output is set to xBPI mode. | Reset the menu to the factory settings. If the problem occurs again: Contact Sartorius Service. | |
| SYS.ERR. | The system data is faulty. | A memory error exists in the control unit. | Switch the device off and on again. If the problem occurs again: Contact Sartorius Service. | |
| ERR 02 | The device cannot be calibrated when starting the calibration function due to a zero point error. | The device was not tared or zeroed before calibration. The device is loaded. | Tare or zero the device. Check the preload and set if necessary. Remove the sample from the weighing pan. | |
| ERR 10 | Taring is not possible. | The device cannot be manually tared because an application program has the tare memory reserved. | To release the tare memory: Exit the application program with the [Back] button. | |
| ERR 11 | The weight value cannot be saved in the tare memory. | The weight value is negative or "zero". | Check the sample being weighed. Zero the device before placing the sample on the balance if necessary. | |
| ERR 520 to ERR 527 | The component replacement is faulty. The software update could not be completed. | The firmware versions of the available components do not match. | Check the device's firmware. Perform a software update. If the problem occurs again: Contact Sartorius Service. | 9.6, 60 |

10.3 Troubleshooting

| Fault | Cause | Remedy | Chapter, page |
|---|---|---|---------------|
| The operating display is blank. | The device is disconnected. | Check the connection to the power supply. | 6.3, 35 |
| | The AC adapter is not connected. | Connect the power supply cable to the power supply. | 6.3, 35 |
| The displayed weight value changes constantly. | The installation site is unstable. | Adjust the parameter for the ambient conditions. | |
| | A foreign object is positioned between the weighing pan and the housing. | Remove the foreign object. | 5.2, 26 |
| The weight readout displayed by the device is obviously wrong. | The device was not calibrated. | Calibrate the device. | |
| | The device was not tared before weighing. | Tare the device. | |
| The [Leveling] display flashes. | The device must be leveled. | Level the device. | 8.2, 49 |
| For a conformity-assessed device: The [Invalid weight value] display appears. | The cause of this fault is displayed after pressing the [Change] key. At the same time, the "Toggle between weight units" function is locked. | | |
| | – LEVEL.ERR.: The device must be leveled. | Level the device. | 8.2, 49 |
| | – ISOCAL.ERR.: The device must be calibrated. | Calibrate the device. | |
| | – WARMUP.xx.: The device is in the warm-up phase and has not yet reached its operating temperature. xx = remaining time in minutes | Comply with the warm-up time after switching the device on. | 8.1, 49 |
| | – VALUE.ERR.: The displayed value is invalid. | Set the device to zero. | |

11 Decommissioning

11.1 Decommissioning the Device

Procedure

- ▶ Turn the device off.
- ▶ Disconnect the device from the power supply.
- ▶ Disconnect the device from all connected devices and all accessories, e.g. printer or electronics module.
- ▶ Device with an analytical draft shield or flat glass draft shield: Remove the draft shield side panels and upper panel (see Chapter "9.2 Preparing a Device with a Frame Draft Shield", page 58).
- ▶ Clean the device (see Chapter "9.3 Cleaning the Device", page 58).
- ▶ Re-insert all components into the device (see Chapter "5.6 Installing a Device with an Analytical Draft Shield or Flat Glass Draft Shield", page 29, Chapter "5.7 Installing a Device with a Frame Draft Shield", page 32).
- ▶ If below-balance weighing has been set up:
 - ▶ Turn the device on its side and place it on a soft support base.
 - ▶ Remove the hook for below-balance weighing from the thread.
 - ▶ Insert the hook for below-balance weighing (2) into its retainer on the underside of the weighing module.
 - ▶ Re-insert the cover of the below-balance weighing equipment (1).
 - ▶ Place the device on the device base on a level surface.

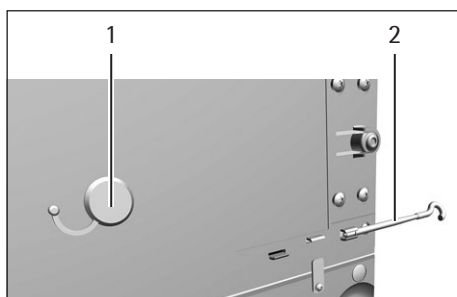

12 Transport

12.1 Transporting the Device

Procedure

- ▶ **⚠ CAUTION** Risk of injury from breaking glass! Glass components can break if they fall or are handled incorrectly. Glass fragments can cause cuts.
 - ▶ Only lift the device by its base, **not** by the draft shield.



- ▶ When lifting and transporting, ensure that **no** personnel or objects are in the way.
- ▶ Get help from additional persons when lifting and transporting the device.
- ▶ Use suitable conveyance devices, e.g., trolleys, for long transport routes.

13 Storage and Shipping

13.1 Storage

Procedure

- ▶ Turn the device off.
- ▶ Disconnect the device from the power supply.
- ▶ Disconnect the device from all connected devices and all accessories, e.g. printer.
- ▶ Clean the device (see Chapter "9.3 Cleaning the Device", page 58).
- ▶ Store the device according to the ambient conditions (see Chapter 15.6, page 69).

13.2 Returning Device and Parts

Defective devices or device components can be returned to Sartorius. Returned devices must be clean, decontaminated, and properly packed, e.g. in the original packaging.

Transport damage as well as measures for subsequent cleaning and disinfection of the device or device components by Sartorius shall be charged to the sender.

WARNING

Risk of injury due to contaminated devices!

Devices contaminated with hazardous materials (nuclear, biological, or chemical – NBC) will **not** be accepted for repair or disposal.

- ▶ Observe the information on decontamination (see Chapter 14.1, page 66).
-

Procedure

- ▶ Disconnect the device from the power supply.
- ▶ Disconnect the device from all connected devices and all accessories, e.g. printer.
- ▶ Clean the device.
- ▶ Contact Sartorius Service for instructions on how to return devices or device components (please refer to www.sartorius.com for return instructions).
- ▶ Pack the device and the device components properly for return, e.g. in the original packaging.

14 Disposal

14.1 Information on Decontamination

The device does **not** contain any hazardous materials that would necessitate special disposal actions.

Contaminated samples used during the process are potentially hazardous materials that could cause biological or chemical hazards.

If the device has come into contact with hazardous substances: Steps must be taken to ensure proper decontamination and declaration. The operator is responsible for adhering to local government regulations on the proper declaration of transport and disposal and the proper disposal of the device.

WARNING

Risk of injury due to contaminated devices!

Devices contaminated with hazardous materials (NBC contamination) will **not** be accepted by Sartorius for repair or disposal.

14.2 Dispose of Device and Parts

14.2.1 Information on Disposal

The device and the device accessories must be disposed of properly by disposal facilities.

A lithium cell battery, type CR2032, is installed inside the device. Batteries must be disposed of properly by disposal facilities.

The packaging is made of environmentally friendly materials that can be used as secondary raw materials.

14.2.2 Disposal

Requirements

The device has been decontaminated.

Procedure

- ▶ Dispose of the device. Follow the disposal instructions on our website (www.sartorius.com).
- ▶ Inform the disposal facility that there is a lithium cell battery, type CR2032, installed inside the device.
- ▶ Dispose of the packaging in accordance with local government regulations.

15 Technical Data

15.1 Dimensions and Weight

15.1.1 Semi-microbalance

| | | With manual draft shield | With motorized draft shield |
|--------------------------------|------|--------------------------|-----------------------------|
| | Unit | Value | Value |
| Dimensions | | | |
| Weighing module (L x W x H) | mm | 404 x 240 x 373 | 404 x 240 x 373 |
| Electronics module (L x W x H) | mm | 211 x 240 x 56 | 211 x 240 x 56 |
| Weighing pan size | mm | 85 x 85 | 85 x 85 |
| Weight, approx. | kg | 10.15 | 11.65 |

15.1.2 Analytical Balance

| | | With manual draft shield | With motorized draft shield |
|------------------------|------|--------------------------|-----------------------------|
| | Unit | Value | Value |
| Dimensions (L x W x H) | mm | 425 x 240 x 373 | 425 x 240 x 373 |
| Weighing pan size | mm | 85 x 85 | 85 x 85 |
| Weight, approx. | kg | 8.2 | 10.0 |

15.1.3 Precision Balance

| | | With frame draft shield | With flat glass draft shield | With manual analytical draft shield | With motorized analytical draft shield |
|------------------------|------|-------------------------|------------------------------|-------------------------------------|--|
| | Unit | Value | Value | Value | Value |
| Dimensions (L x W x H) | mm | 425 x 240 x 122 | 425 x 240 x 284 | 425 x 240 x 373 | 425 x 240 x 373 |
| Weighing pan size | mm | 140 x 140 | 140 x 140 | 140 x 140 | 140 x 140 |
| Weight, approx. | kg | 5.9 | 7.5 | 9.4 | 10.2 |

15.2 Power Supply

15.2.1 Device

Only by Sartorius AC adapter YEPS03-15V0

15.2.2 Power Supply Unit

| | Unit | Value |
|---|------|------------------|
| Item No. | | YEPS03-15V0 |
| Primary | | |
| AC voltage | V | 100 – 240 (±10%) |
| Frequency | Hz | 50 – 60 (±5%) |
| Current consumption, maximum | A | 1.0 |
| Secondary | | |
| DC voltage at 2 A output current | V | 14.25 – 15.75 |
| Power, maximum | W | 30 |
| Short circuit protection: Electronic | | |
| Protection class according to IEC 62368-1 | | I |
| Pollution level according to IEC 61010-1 | | 2 |
| Overvoltage category according to IEC 606641-1 | | II |
| Installation site according to IEC 62368-1, maximum altitude above sea level | m | 5000 |
| Temperature | | |
| In operation | °C | 0 – +40 |
| During storage and transport | °C | -20 – +80 |
| Connector for mains connection according to IEC 60320-1 / C14: 3-pin | | |
| Power supply cable | | |
| Power supply cable according to IEC 60320-1 / C14: Country-specific, 3-pin, two-sided plug | | |
| Other data: See label on AC adapter | | |

15.2.3 Safety of Electrical Equipment

According to EN 61010-1/IEC 61010-1 Safety requirements for electrical equipment for measurement, control, and laboratory use – Part 1: General Requirements

15.2.4 Electromagnetic Compatibility

Interference resistance

Suitable for use in industrial areas

Transient emissions

Class B

Suitable for use in residential areas and areas that are connected to a low voltage network that also supplies residential buildings.

15.3 Materials

Housing: Die-cast aluminum, plastic PBT, Optiwhite float and stainless steel 1.4401 | 1.4404, PA handles, aluminum trim

Control unit: Plastic PBT, float glass and stainless steel 1.4301

15.4 Integrated Clock

| | Unit | Value |
|-----------------------------------|------|-------|
| Maximum deviation per month (RTC) | s | 30 |

15.5 Backup Battery

| | Unit | Value |
|---|-------|-------|
| Lithium battery, type CR2032 | | |
| Service life at room temperature, minimum | Years | 10 |

15.6 Ambient Conditions

15.6.1 Installation Site

| | Unit | Value |
|---|------|-----------|
| Installation site | | |
| Standard laboratory rooms | | |
| Installation site according to IEC 60259-1, maximum altitude above sea level | m | 3000 |
| For indoor use only | | |
| Temperature | | |
| In operation | °C | +5 – +40 |
| In operation for conformity-assessed devices: See information on the device's ID plate | | |
| During storage and transport | °C | -20 – +60 |
| Relative humidity | | |
| At temperatures of up to 31 °C | % | 80 |
| Then linear decrease from 80 % at 31 °C to 50 % at 40 °C | | |
| No heat from heating systems or direct sunlight | | |
| No drafts from open windows, AC systems, or doors | | |
| No vibrations | | |
| No "heavy traffic" areas (personnel) | | |
| No electromagnetic fields | | |
| No dry air | | |

15.6.2 Ambient Temperature for the isoCAL Function

| | | MCE225S | MCE225P | MCE125S | MCE125P |
|--|------|-----------|-----------|-----------|-----------|
| | Unit | Value | Value | Value | Value |
| Scope of application as per Directive 2014/31/EU | | | | | |
| With isoCAL function | °C | +10 – +30 | +10 – +30 | +10 – +30 | +10 – +30 |
| Without isoCAL function | °C | +17 – +27 | +17 – +27 | +17 – +27 | +17 – +27 |

| | | MCE524S | MCE524P | MCE324S | MCE324P |
|--|------|-----------|-----------|-----------|-----------|
| | Unit | Value | Value | Value | Value |
| Scope of application as per Directive 2014/31/EU | | | | | |
| With isoCAL function | °C | +10 – +30 | +10 – +30 | +10 – +30 | +10 – +30 |
| Without isoCAL function | °C | - | - | +17 – +27 | +17 – +27 |

| | | MCE224S | MCE124S | MCE5203S | MCE5203P |
|--|------|-----------|-----------|-----------|-----------|
| | Unit | Value | Value | Value | Value |
| Scope of application as per Directive 2014/31/EU | | | | | |
| With isoCAL function | °C | +10 – +30 | +10 – +30 | +10 – +30 | +10 – +30 |
| Without isoCAL function | °C | +17 – +27 | +17 – +27 | - | - |

| | | MCE3203S | MCE2203S | MCE2203P | MCE1203S |
|--|------|-----------|-----------|-----------|-----------|
| | Unit | Value | Value | Value | Value |
| Scope of application as per Directive 2014/31/EU | | | | | |
| With isoCAL function | °C | +10 – +30 | +10 – +30 | +10 – +30 | +10 – +30 |
| Without isoCAL function | °C | +17 – +27 | +17 – +27 | +17 – +27 | +17 – +27 |

| | | MCE623S | MCE623P | MCE323S | MCE5202S |
|--|------|-----------|-----------|-----------|-----------|
| | Unit | Value | Value | Value | Value |
| Scope of application as per Directive 2014/31/EU | | | | | |
| With isoCAL function | °C | +10 – +30 | +10 – +30 | +10 – +30 | +10 – +30 |
| Without isoCAL function | °C | +10 – +30 | +10 – +30 | +10 – +30 | +17 – +27 |

15.6.3 Protection Class

IP Protection: Protected against dust and water

15.7 Metrological Data

15.7.1 Models MCE225S | MCE225P | MCE125S | MCE125P

| | | MCE225S | MCE225P | MCE125S | MCE125P |
|--|-------|---------|--------------------|---------|------------|
| | Unit | Value | Value | Value | Value |
| Scale interval (d) | mg | 0.01 | 0.01 0.02 0.05 | 0.01 | 0.01 0.1 |
| Maximum capacity (Max) | g | 220 | 60 120 220 | 120 | 60 120 |
| Repeatability at 5 % load | | | | | |
| Standard deviation of the load values, tolerance | mg | 0.015 | 0.015 | 0.015 | 0.015 |
| Standard deviation of the load values, typical value | mg | 0.01 | 0.01 | 0.01 | 0.01 |
| Repeatability at approx. maximum capacity | | | | | |
| Standard deviation of the load values, tolerance | mg | 0.025 | 0.04 | 0.025 | 0.06 |
| Standard deviation of the load values, typical value | mg | 0.02 | 0.02 | 0.02 | 0.02 |
| Linearity deviation | | | | | |
| Tolerance | mg | 0.1 | 0.15 | 0.1 | 0.15 |
| Typical value | mg | 0.065 | 0.1 | 0.065 | 0.1 |
| Deviation when load is off-center, positions according to OIML R76 | | | | | |
| Test weight | g | 100 | 100 | 50 | 50 |
| Tolerance | mg | 0.15 | 0.2 | 0.15 | 0.2 |
| Typical value | mg | 0.1 | 0.1 | 0.1 | 0.1 |
| Sensitivity drift between +10 °C and +30 °C | ppm/K | 1 | 1 | 1 | 1 |
| Tare-maximum capacity: Less than 100 % of maximum capacity | | | | | |
| Accuracy class according to Directive 2014/31/EU | | I | I | I | I |
| Verification scale interval (e) according to Directive 2014/31/EU | mg | 1 | 1 | 1 | 1 |
| Minimum load (Min) according to Directive 2014/31/EU | mg | 1 | 1 | 1 | 1 |
| Minimum initial weighing according to USP (United States Pharmacopeia), Chap. 41 | | | | | |
| Optimum minimum initial weighing | mg | 8.2 | 8.2 | 8.2 | 8.2 |
| Typical minimum initial weighing | mg | 20 | 20 | 20 | 20 |
| Typical stabilization time | s | 2 | 2 | 2 | 2 |
| Typical measurement time | s | 6 | 6 | 6 | 6 |

15.7.2 Models MCE524S | MCE524P | MCE324S | MCE324P

| | | MCE524S | MCE524P | MCE324S | MCE324P |
|--|-------|---------|-----------------|---------|-----------------|
| | Unit | Value | Value | Value | Value |
| Scale interval (d) | mg | 0.1 | 0.1 0.2 0.5 | 0.1 | 0.1 0.2 0.5 |
| Maximum capacity (Max) | g | 520 | 120 240 520 | 320 | 80 160 320 |
| Repeatability at 5 % load | | | | | |
| Standard deviation of the load values, tolerance | mg | 0.08 | 0.08 | 0.08 | 0.08 |
| Standard deviation of the load values, typical value | mg | 0.04 | 0.04 | 0.04 | 0.04 |
| Repeatability at approx. maximum capacity | | | | | |
| Standard deviation of the load values, tolerance | mg | 0.1 | 0.15 | 0.1 | 0.1 |
| Standard deviation of the load values, typical value | mg | 0.05 | 0.05 | 0.05 | 0.05 |
| Linearity deviation | | | | | |
| Tolerance | mg | 0.4 | 0.5 | 0.3 | 0.5 |
| Typical value | mg | 0.2 | 0.2 | 0.2 | 0.2 |
| Deviation when load is off-center, positions according to OIML R76 | | | | | |
| Test weight | g | 200 | 200 | 200 | 200 |
| Tolerance | mg | 0.3 | 0.4 | 0.3 | 0.4 |
| Typical value | mg | 0.2 | 0.2 | 0.2 | 0.2 |
| Sensitivity drift between +10 °C and +30 °C | ppm/K | 1 | 1 | 1 | 1 |
| Tare-maximum capacity: Less than 100 % of maximum capacity | | | | | |
| Accuracy class according to Directive 2014/31/EU | | I | I | I | I |
| Verification scale interval (e) according to Directive 2014/31/EU | mg | 1 | 1 | 1 | 1 |
| Minimum load (Min) according to Directive 2014/31/EU | mg | 10 | 10 | 10 | 10 |
| Minimum initial weighing according to USP (United States Pharmacopeia), Chap. 41 | | | | | |
| Optimum minimum initial weighing | mg | 82 | 82 | 82 | 82 |
| Typical minimum initial weighing | mg | 82 | 82 | 82 | 82 |
| Typical stabilization time | s | 1 | 1 | 1 | 1 |
| Typical measurement time | s | 3 | 3 | 3 | 3 |

15.7.3 Models MCE224S | MCE124S | MCE5203S | MCE5203P

| | | MCE224S | MCE124S | MCE5203S | MCE5203P |
|--|-------|---------|---------|----------|--------------------|
| | Unit | Value | Value | Value | Value |
| Scale interval (d) | mg | 0.1 | 0.1 | 1 | 1 2 5 |
| Maximum capacity (Max) | g | 220 | 120 | 5200 | 1200 2400 5200 |
| Repeatability at 5 % load | | | | | |
| Standard deviation of the load values, tolerance | mg | 0.07 | 0.1 | 1 | 1 |
| Standard deviation of the load values, typical value | mg | 0.05 | 0.05 | 0.6 | 0.6 |
| Repeatability at approx. maximum capacity | | | | | |
| Standard deviation of the load values, tolerance | mg | 0.07 | 0.1 | 1 | 1 |
| Standard deviation of the load values, typical value | mg | 0.05 | 0.05 | 0.6 | 0.6 |
| Linearity deviation | | | | | |
| Tolerance | mg | 0.2 | 0.2 | 5 | 5 |
| Typical value | mg | 0.13 | 0.13 | 2 | 3 |
| Deviation when load is off-center, positions according to OIML R76 | | | | | |
| Test weight | g | 100 | 50 | 2000 | 2000 |
| Tolerance | mg | 0.2 | 0.2 | 2 | 2 |
| Typical value | mg | 0.12 | 0.12 | 1 | 1 |
| Sensitivity drift between +10 °C and +30 °C | ppm/K | 1 | 1 | 1 | 1 |
| Tare-maximum capacity: Less than 100 % of maximum capacity | | | | | |
| Accuracy class according to Directive 2014/31/EU | | I | I | I | I |
| Verification scale interval (e) according to Directive 2014/31/EU | mg | 1 | 1 | 10 | 10 |
| Minimum load (Min) according to Directive 2014/31/EU | mg | 10 | 10 | 100 | 100 |
| Minimum initial weighing according to USP (United States Pharmacopeia), Chap. 41 | | | | | |
| Optimum minimum initial weighing | mg | 82 | 82 | 820 | 820 |
| Typical minimum initial weighing | mg | 100 | 100 | 1200 | 1200 |
| Typical stabilization time | s | 1 | 1 | 1 | 1 |
| Typical measurement time | s | 3 | 3 | 2 | 2 |

15.7.4 Models MCE3203S | MCE2203S | MCE2203P | MCE1203S

| | | MCE3203S | MCE2203S | MCE2203P | MCE1203S |
|--|-------|----------|----------|-------------|----------|
| | Unit | Value | Value | Value | Value |
| Scale interval (d) | mg | 1 | 1 | 1 10 | 1 |
| Maximum capacity (Max) | g | 3200 | 2200 | 1010 2200 | 1200 |
| Repeatability at 5 % load | | | | | |
| Standard deviation of the load values, tolerance | mg | 1 | 0.7 | 0.7 | 0.7 |
| Standard deviation of the load values, typical value | mg | 0.6 | 0.5 | 0.5 | 0.5 |
| Repeatability at approx. maximum capacity | | | | | |
| Standard deviation of the load values, tolerance | mg | 1 | 1 | 1 | 0.7 |
| Standard deviation of the load values, typical value | mg | 0.6 | 0.6 | 0.6 | 0.6 |
| Linearity deviation | | | | | |
| Tolerance | mg | 5 | 3 | 5 | 2 |
| Typical value | mg | 2 | 2 | 3 | 1 |
| Deviation when load is off-center, positions according to OIML R76 | | | | | |
| Test weight | g | 1000 | 1000 | 1000 | 500 |
| Tolerance | mg | 2 | 2 | 3 | 2 |
| Typical value | mg | 1 | 1 | 2 | 1 |
| Sensitivity drift between +10 °C and +30 °C | ppm/K | 1 | 1 | 1 | 1.5 |
| Tare-maximum capacity: Less than 100 % of maximum capacity | | | | | |
| Accuracy class according to Directive 2014/31/EU | | I | I | I | I |
| Verification scale interval (e) according to Directive 2014/31/EU | mg | 10 | 10 | 10 | 10 |
| Minimum load (Min) according to Directive 2014/31/EU | mg | 100 | 100 | 100 | 100 |
| Minimum initial weighing according to USP (United States Pharmacopeia), Chap. 41 | | | | | |
| Optimum minimum initial weighing | mg | 820 | 820 | 820 | 820 |
| Typical minimum initial weighing | mg | 1200 | 1000 | 1000 | 1000 |
| Typical stabilization time | s | 1 | 1 | 1 | 1 |
| Typical measurement time | s | 2 | 1.5 | 1.5 | 1.5 |

15.7.5 Models MCE623S | MCE623P | MCE323S | MCE5202S

| | | MCE623S | MCE623P | MCE323S | MCE5202S |
|--|-------|---------|-------------|---------|----------|
| | Unit | Value | Value | Value | Value |
| Scale interval (d) | mg | 1 | 1/2/5 | 1 | 10 |
| Maximum capacity (Max) | g | 620 | 150/300/620 | 320 | 5200 |
| Repeatability at 5 % load | | | | | |
| Standard deviation of the load values, tolerance | mg | 0.7 | 1 | 0.7 | 6 |
| Standard deviation of the load values, typical value | mg | 0.4 | 0.4 | 0.4 | 2 |
| Repeatability at approx. maximum capacity | | | | | |
| Standard deviation of the load values, tolerance | mg | 0.7 | 1 | 0.7 | 6 |
| Standard deviation of the load values, typical value | mg | 0.5 | 0.5 | 0.5 | 2 |
| Linearity deviation | | | | | |
| Tolerance | mg | 2 | 5 | 2 | 10 |
| Typical value | mg | 0.6 | 1.5 | 0.6 | 5 |
| Deviation when load is off-center, positions according to OIML R76 | | | | | |
| Test weight | g | 200 | 200 | 200 | 2000 |
| Tolerance | mg | 2 | 4 | 2 | 10 |
| Typical value | mg | 1 | 3 | 1 | 5 |
| Sensitivity drift between +10 °C and +30 °C | ppm/K | 2 | 2 | 2 | 2 |
| Tare-maximum capacity: Less than 100 % of maximum capacity | | | | | |
| Accuracy class according to Directive 2014/31/EU | | II | II | II | I |
| Verification scale interval (e) according to Directive 2014/31/EU | mg | 10 | 10 | 10 | 100 |
| Minimum load (Min) according to Directive 2014/31/EU | mg | 20 | 20 | 20 | 1000 |
| Minimum initial weighing according to USP (United States Pharmacopeia), Chap. 41 | | | | | |
| Optimum minimum initial weighing | mg | 820 | 820 | 820 | 8200 |
| Typical minimum initial weighing | mg | 820 | 820 | 820 | 8200 |
| Typical stabilization time | s | 0.8 | 0.8 | 0.8 | 0.8 |
| Typical measurement time | s | 1 | 1 | 1 | 1 |

15.8 Recommended Calibration Weight

| | | MCE225S | MCE225P | MCE125S | MCE125P |
|----------------------------|------|---------|---------|---------|---------|
| | Unit | Value | Value | Value | Value |
| External test weight | g | 200 | 200 | 100 | 100 |
| Recommended accuracy class | | E2 | E2 | E2 | E2 |

| | | MCE524S | MCE524P | MCE324S | MCE324P |
|----------------------------|------|---------|---------|---------|---------|
| | Unit | Value | Value | Value | Value |
| External test weight | g | 500 | 500 | 300 | 300 |
| Recommended accuracy class | | E2 | E2 | E2 | E2 |

| | | MCE224S | MCE124S | MCE5203S | MCE5203P |
|----------------------------|------|---------|---------|----------|----------|
| | Unit | Value | Value | Value | Value |
| External test weight | g | 200 | 100 | 5000 | 5000 |
| Recommended accuracy class | | E2 | E2 | E2 | E2 |

| | | MCE3203S | MCE2203S | MCE2203P | MCE1203S |
|----------------------------|------|----------|----------|----------|----------|
| | Unit | Value | Value | Value | Value |
| External test weight | g | 3000 | 2000 | 1000 | 1000 |
| Recommended accuracy class | | E2 | E2 | E2 | E2 |

| | | MCE623S | MCE623P | MCE323S | MCE5202S |
|----------------------------|------|---------|---------|---------|----------|
| | Unit | Value | Value | Value | Value |
| External test weight | g | 500 | 500 | 200 | 5000 |
| Recommended accuracy class | | E2 | E2 | E2 | E2 |

15.9 isoCAL Function

15.9.1 Models MCE225S | MCE225P | MCE125S | MCE125P | MCE524S | MCE524P | MCE324S | MCE324P | MCE224S | MCE124S | MCE5203S | MCE5203P | MCE3203S | MCE2203S | MCE2203P | MCE1203S

| | Unit | Value |
|--|------|-------|
| isoCAL is triggered by the following criteria: | | |
| In the event of a temperature change | K | 1.5 |
| After a time interval | h | 12 |
| After successful leveling | | |

15.9.2 Models MCE5202S | MCE623S | MCE623P | MCE323S

| | Unit | Value |
|--|------|-------|
| isoCAL is triggered by the following criteria: | | |
| In the event of a temperature change | K | 2 |
| After a time interval | h | 12 |
| After successful leveling | | |

15.10 Interfaces

15.10.1 Specifications for the COM-RS232 Interface

| |
|-------------------------------------|
| Type of interface: Serial interface |
| Interface operation: Full duplex |
| Level: RS232 |
| Connection: D-sub connector, 9-pin |
| Maximum cable length: 10 m |

Pin assignment

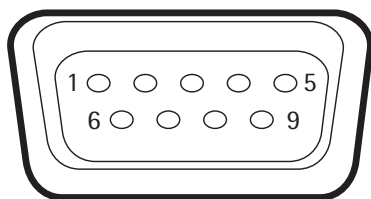

- Pin 1: **Not** assigned
- Pin 2: Data output (TxD)
- Pin 3: Data input (RxD)
- Pin 4: **Not** assigned
- Pin 5: Internal ground
- Pin 6: **Not** assigned
- Pin 7: Clear to Send (CTS)
- Pin 8: Request to Send (RTS)
- Pin 9: **Not** assigned

15.10.2 Specifications for the USB-A Interface

| |
|--|
| Communication: USB host (master) |
| Connectable devices: Sartorius printers, USB sticks with software update |

15.10.3 Specifications for the USB-B Interface

| |
|---|
| Communication: USB device (slave) |
| Type of interface: Virtual serial interface (virtual COM-port, VCP) and "PC direct" communication |

16 Accessories

16.1 Accessories

This table contains an excerpt of the accessories that can be ordered. For information on other products, contact Sartorius.

16.1.1 Printers and Communication

| Item | Quantity | Order number |
|--|----------|--------------|
| Thermal transfer thermal printer for GLP/GMP printouts on continuous paper and labels | 1 | YDP30 |
| Standard paper and ink ribbon, set, 90 m, for YDP30 | 1 | 69Y03285 |
| Self-adhesive paper and ink ribbon, 90 m, for YDP30 | 1 | 69Y03286 |
| Standard thermal paper, 24 m roll, for YDP30 YDP40 | 5 | 69Y03287 |
| Self-adhesive thermal paper, 13 m roll, for YDP30 | 5 | 69Y03288 |
| Self-adhesive labels for YDP30 | | |
| 58 mm x 100 mm | 350 | 69Y03094 |
| 58 mm x 76 mm | 500 | 69Y03093 |
| 58 mm x 30 mm | 1000 | 69Y03092 |
| Display cable, 3 m, for separate installation of display and weighing units, installation by Sartorius Service or at the factory (order code VF4016) | 1 | On request |
| Installation of display cable, 3 m, for separate installation of display and weighing units | 1 | VF4016 |
| Cable, 3 m, between the weighing module and electronics module for semi-microbalance | 1 | YCC01-MSM3 |
| RS232C connection cable, 9-pin, 3 m, for connection to a PC with 9-pin COM port | 1 | On request |
| Sartorius Wedge, software for data communication between the PC and balance | 1 | YSW02 |

16.1.2 Displays and Input/Output Elements

| Item | Quantity | Order number |
|---|----------|--------------|
| Display and control unit with color TFT graphic display and touch screen | 1 | YAC01MCA |
| Motion sensor for triggering a maximum of 4 functions via gesture control, selection via menu | 1 | YHS02MS |

16.1.3 Hardware for Pipette Calibration

| Item | Quantity | Order number |
|--|----------|--------------|
| Pipette calibration kit for semi-microbalance and analytical balance; consists of a moisture trap and all necessary adapters | 1 | YCP04MS |

16.1.4 Filter Balance and Antistatic Accessories

| Item | Quantity | Order number |
|--|----------|--------------|
| Antistatic weighing pan, 130 mm diameter, for weighing module for semi-microbalance and analytical balance | 1 | YWP04MS |
| Ionization blower for electrostatically charged samples | 1 | YIB01-ODR |
| Stat-Pen ionization pen for discharging electrostatically charged samples | 1 | YSTP01 |
| Ionizer | | |
| with u-shaped electrode for 230 V | 1 | YIB02-230V |
| with u-shaped electrode for 115 V | 1 | YIB02-115V |

16.1.5 Special Applications

| Item | Quantity | Order number |
|--|----------|--------------|
| Density determination set for solids and liquids | | |
| for semi-microbalance and analytical balance | 1 | YDK03MS |
| for precision balance | 1 | YDK04MS |

16.1.6 Weighing Tables

| Item | Quantity | Order number |
|---|----------|--------------|
| Weighing table | | |
| made from synthetic stone, with vibration dampening | 1 | YWT03 |
| made from wood with synthetic stone | 1 | YWT09 |
| Wall console | 1 | YWT04 |









16.1.7 Weighing Accessories

| Item | Quantity | Order number |
|--|----------|--------------|
| Weighing scoop made from chrome-nickel steel, L 90 mm x W 32 mm x H 8 mm | 1 | 641214 |

| Item | Quantity | Order number |
|--|----------|--------------|
| Stand | | |
| For weighing modules with scale intervals of 10 mg 100 mg for raising the operating unit | 1 | YDH03MS |

16.1.8 Sample Holder

| Item | Quantity | Order number |
|--|----------|--------------|
| Flexible sample holder for weighing vessels and filters with diameters of up to 120 mm, replaces the original weighing pan, for semi-microbalance and analytical balance | 1 | YFH01MS |

| Item | Image | Quantity | Order number |
|---|---|----------|--------------|
| Holder for analytical and semi-microbalance | | | |
| for reaction vessels, 1.5 ml – 2 ml |  | 1 | YSH15 |
| for reaction vessels, 5 ml |  | 1 | YSH19 |
| for laboratory vessels |  | 1 | YSH23 |
| for weighing scoops |  | 1 | YSH26 |
| for filters, 150 mm diameter |  | 1 | YSH30 |
| for titration vessel |  | 1 | YSH37 |
| for syringes, horizontal |  | 1 | YSH42 |
| for syringes, vertical |  | 1 | YSH46 |

17 Sartorius Service

Sartorius Service is available for queries regarding the device. For information about the service addresses, services provided, or to contact a local representative, please visit the Sartorius website (www.sartorius.com).

When contacting Sartorius Service with questions about the system or in the event of malfunctions, be sure to have the device information, e.g., serial number, hardware, firmware, configuration, close at hand. Consult the information on the manufacturer's ID label and in the "Device Information" menu (see Chapter "4.5.1 Overview of the Device Settings Menu", page 20).

18 Conformity & Certificates

18.1 EU Declaration of Conformity

The attached Declaration of Conformity hereby confirms compliance of the device with the directives cited.

M The declaration of conformity supplied here is for conformity-assessed (verified) balances for use in the EEA. Please keep it in a safe place.



Original

EG-/EU-Konformitätserklärung EC / EU Declaration of Conformity

Hersteller
Manufacturer Sartorius Lab Instruments GmbH & Co. KG
37070 Goettingen, Germany

erklärt in alleiniger Verantwortung, dass das Betriebsmittel
declares under sole responsibility that the equipment

Geräteart
Device type Elektronische Präzisions-, Milligramm-, Analysen-, Semimikro-, Mikro-Klein- und Hochlastwaage
Electronical Precision, Milligram, Analytical, Semi micro, Micro-Small, and High-Capacity Balance

Baureihe
Type series MCAvw-2x-y, MCEvw-2x-y,
v = 2.7, 3.6, 6.6, 10.6, 124, 125, 224, 225, 323, 324, 524, 623, 1202, 1203, 2202, 2203, 3203, 4202,
5201, 5202, 5203, 6202, 8201, 8202, 10202, 11201, 12201, 14202, 20201, 32202, 36200, 36201,
50201, 70200, 70201;
w = S, P; x = S00, S01, CEU, CFR, CCN, OBR, OIN, ORU, OJP; y = A, E, F, I, M, O, R, U

in der von uns in Verkehr gebrachten Ausführung allen einschlägigen Bestimmungen der folgenden Europäischen Richtlinien – einschließlich deren zum Zeitpunkt der Erklärung geltenden Änderungen – entspricht und die anwendbaren Anforderungen folgender harmonisierter Europäischer Normen erfüllt:
in the form as delivered fulfils all the relevant provisions of the following European Directives – including any amendments valid at the time this declaration was signed – and meets the applicable requirements of the harmonized European Standards listed below:

2014/30/EU Elektromagnetische Verträglichkeit
Electromagnetic compatibility
EN 61326-1:2013

2006/42/EG
2006/42/EC Maschinen
Machines
EN ISO 12100:2010, EN 61010-1:2010

2011/65/EU Beschränkung der Verwendung bestimmter gefährlicher Stoffe in Elektro- und Elektronikgeräten (RoHS)
Restriction of the use of certain hazardous substances in electrical and electronic equipment (RoHS)
EN 50581:2012

Die Person, die bevollmächtigt ist, die technischen Unterlagen zusammenzustellen:
The person authorised to compile the technical file: Sartorius Lab Instruments GmbH & Co. KG
International Certification Management
37070 Goettingen, Germany

Jahreszahl der CE-Kennzeichenvergabe | *Year of the CE mark assignment:* 18

Sartorius Lab Instruments GmbH & Co. KG
Goettingen, 2018-06-20

Dr. Reinhard Baumfalk
Vice President R&D

Dr. Dieter Klausgrete
Head of International Certification Management

Diese Erklärung bescheinigt die Übereinstimmung mit den genannten EG- und EU-Richtlinien, ist jedoch keine Zusicherung von Eigenschaften. Bei einer mit uns nicht abgestimmten Änderung des Produktes verliert diese Erklärung ihre Gültigkeit. Die Sicherheitshinweise der zugehörigen Produktdokumentation sind zu beachten.

This declaration certifies conformity with the above mentioned EC and EU Directives, but does not guarantee product attributes. Unauthorised product modifications make this declaration invalid. The safety information in the associated product documentation must be observed.



Certificate: 70185847

Master Contract: 167555

Project: 70185847

Date Issued: 2018-09-24

APPLICABLE REQUIREMENTS

CSA Standards:

CAN/CSA-C22.2 No. 61010-1-12 - Safety Requirements for Electrical Equipment for Measurement, Control, and Laboratory Use, Part 1: General Requirements

UL Standards:

UL Std. No. 61010-1 (3rd Edition) - Safety Requirements for Electrical Equipment for Measurement, Control, and Laboratory Use - Part 1: General Requirements

CONDITIONS OF ACCEPTABILITY

- (1) Equipment is intended to be used with power supply FSP Group Inc, Model FSP030-DGAN3 or Sinpro Electronics Co Ltd, Model SPU31-106 or PSFD rated output 15Vdc, 2A. The equipment can also be used with any other power supply approved for Canada and USA under the 60950-1 or 61010-1 or equivalent standards and which provides Reinforced insulation between mains and secondary circuits. It must be rated for 3000m and up to 40°C and must provide an output of 15Vdc LPS with a minimum of 1A
- (2) Detachable cord set, to be delivered with the product, consisting of minimum NEMA 5-15 Plug, 3 x 18AWG cable and C13 Appliance coupler. For countries outside Canada and the USA the cable must be equivalent and must fulfill the national requirements for detachable cord sets.

18.3 FCC Supplier's Declaration of Conformity

FCC Supplier's Declaration of Conformity



Device type Electronical Precision, Milligram, Analytical, Semi Micro, Micro-Small and High-Capacity Balance

Type series **MCAvw-2x-y, MCEvw-2x-y**

v = 2.7, 3.6, 6.6, 10.6, 124, 125, 224, 225, 323, 324, 524, 623, 1202, 1203, 2202, 2203, 3203, 4202, 5201, 5202, 5203, 6202, 8201, 8202, 10202, 11201, 12201, 14202, 20201, 32202, 36200, 36201, 50201, 70200, 70201

w = S, P

x = S00, S01, CEU, CFR, CCN, OBR, OIN, ORU, OJP

y = A, E, F, I, M, O, R, U

Party issuing Supplier's Declaration of Conformity / Responsible Party – U.S. Contact Information

Sartorius Corporation
5 Orville Dr Suite 200
11716 Bohemia, NY
USA
Telephone: +1.631.254.4249

FCC Compliance Statement

This device complies with Part 15 of the FCC Rules. Operation is subject to the following two conditions: (1) This device may not cause harmful interference, and (2) this device must accept any interference received, including interference that may cause undesired operation.

Information to the user

This equipment has been tested and found to comply with the limits for a **class B** digital device, pursuant to part 15 of the FCC Rules. These limits are designed to provide reasonable protection against harmful interference in a residential installation. This equipment generates, uses and can radiate radio frequency energy and if not installed and used in accordance with the instructions, may cause harmful interference to radio communications. However, there is no guarantee that interference will not occur in a particular installation. If this equipment does cause harmful interference to radio or television reception, which can be determined by turning the equipment off and on, the user is encouraged to try to correct the interference by one or more of the following measures:

- Reorient or relocate the receiving antenna.
- Increase the separation between the equipment and receiver.
- Connect the equipment into an outlet on a circuit different from that to which the receiver is connected.
- Consult the dealer or an experienced radio/TV technician for help.

Connections between the device and peripherals must be made using shielded cables in order to maintain compliance with FCC radio frequency emission limits.

Any modifications made to this device that are not approved by Sartorius may void the authority granted to the user by the FCC to operate this equipment.

Doc: 2384181-00 SLI18FCC001-00.en 1 / 1 PMF: 2369813 OP-113_fo1_2015.10.12

Sartorius Lab Instruments GmbH & Co. KG
Otto-Brenner-Strasse 20
37079 Goettingen, Germany

Phone: +49.551.308.0
www.sartorius.com

The information and figures contained in these instructions correspond to the version date specified below.

Sartorius reserves the right to make changes to the technology, features, specifications and design of the equipment without notice.

Masculine or feminine forms are used to facilitate legibility in these instructions and always simultaneously denote the other gender as well.

Copyright notice:

This instruction manual, including all of its components, is protected by copyright.

Any use beyond the limits of the copyright law is not permitted without our approval.

This applies in particular to reprinting, translation and editing irrespective of the type of media used.

© Sartorius Germany

Last updated:

11 | 2018