



Please read user's manual before
operating equipment

Original Instructions

LABCONCO CORPORATION

8811 Prospect Avenue
Kansas City, MO 64132
(800) 821-5525 | +1 (816) 333-8811
labconco.com

User's Manual

Axiom[®] Type C1 Biosafety Cabinets



Register this product

Axiom[®] Type C1 Biosafety Cabinets

2021—Present

30441xxx1

30448xxx1

30461xxx1

30468xxx1

Copyright © 2021 Labconco Corporation. The information contained in this manual and the accompanying products are copyrighted and all rights reserved by Labconco Corporation. Labconco Corporation reserves the right to make periodic design changes without obligation to notify any person or entity of such change.

Warranty

Labconco Corporation provides a warranty to the original buyer for the repair or replacement of parts and reasonable labor as a result of normal and proper use of the equipment with compatible chemicals. Broken glassware and maintenance items, such as filters, gaskets, light bulbs, finishes and lubrication are not warranted. Excluded from warranty are products with improper installation, erratic electrical or utility supply, unauthorized repair, use with incompatible chemicals, or non-factory modifications to the original product.

Purifier® Axiom® Biological Safety Cabinets carry a five-year warranty from date of installation or six years from date of shipment from Labconco, whichever is sooner. Warranty is non-transferable and only applies to the owner (organization) of record.

Buyer is exclusively responsible for the set-up, installation, verification, decontamination or calibration of equipment. This limited warranty covers parts and labor, but not transportation and insurance charges. If the failure is determined to be covered under this warranty, the dealer or Labconco Corporation will authorize repair or replacement of all defective parts to restore the unit to operation. Repairs may be completed by 3rd party service agents approved by Labconco Corporation. Labconco Corporation reserves the rights to limit this warranty based on a service agent's travel, working hours, the site's entry restrictions and unobstructed access to serviceable components of the product.

Under no circumstances shall Labconco Corporation be liable for indirect, consequential, or special damages of any kind. This warranty is exclusive and in lieu of all other warranties whether oral, or implied.

Returned or Damaged Goods

Do not return goods without the prior authorization from Labconco. Unauthorized returns will not be accepted. If your shipment was damaged in transit, you must file a claim directly with the freight carrier. Labconco Corporation and its dealers are not responsible for shipping damages.

The United States Interstate Commerce Commission rules require that claims be filed with the delivery carrier within **fifteen (15) days** of delivery.

Limitation of Liability

The disposal and/or emission of substances used in connection with this equipment may be governed by various federal, state, or local regulations. All users of this equipment are required to become familiar with any regulations that apply in the user's area concerning the dumping of waste materials in or upon water, land, or air and to comply with such regulations. Labconco Corporation is held harmless with respect to user's compliance with such regulations.

For additional questions or support:

Labconco Customer Care +1 (816) 333-8811

Labconco Technical Support (800) 821-5525

Hours 7:30 a.m.-5:30 p.m. CST

**Part #3848340 Rev. -
ECO M149**

Table of Contents

1: INTRODUCTION	9
About This Manual	9
Contents Included	9
2: BEFORE YOU INSTALL	10
Location Requirements	10
Clearance Requirements	11
Electrical Requirements	11
Service Line Requirements	11
Exhaust Requirements	12
Air-Tight Damper	14
3: SAFETY PRECAUTIONS	15
Typographical Conventions	15
General Safety Precautions	17
Safety Precautions for this Product	19
4: INSTALLATION	21
Unpacking	21
Electrical Connection	26
Service Line Connection	27
Exhaust Connection	28
Drain Valve Installation (Optional)	29
Certification	31

5: PERFORMANCE FEATURES 32

Laminar Airflow	32
Directional Airflow	33
Cabinet Air Intake (Front Grille)	33
Chem-Zone™ Directly Exhausted Work Zone	34
HEPA Filters	34
ULPA Filters	35
Motor/Blower	36
UV Lamp (optional)	37

6: MYLOGIC™ OPERATING SYSTEM 38

Home Screen	38
Display Sleep Mode	39
Keypad	39
Main Menu	40
Configuration Submenu	41
	41
Audible Tones	41
Selecting a Language	41
Setting the Clock	42
Setting Automatic Operation Options (Nightsmart™ / SmartStart™)	43
Navigating the Settings Submenu	44
Selecting the Units of Measure	44
Activating the Security Lock	44
Setting the USB Output Rate	44
UV Parameters	45
The Tools Submenu	45
Timer Operation	46
Interval Timer Operation	46
Stopwatch Timer Operation	46
Airflow Alert	47
Resetting the Airflow Alert System	47

Alarms	48
Power Loss Alarm	48
Sash Height Alarm	48
Blower Failure Alarm	48
Exhaust Airflow Check	49
Starting Exhaust Alarm	49
Running Exhaust Alarm – Active Protection	49
Overdriven Exhaust Alarm	50

7: USING YOUR AXIOM TYPE C1 **51**

Feature Overview	51
System Reset Switch	52
Keypad	53
Sash Operation	54
Blower Operation	54
Light Operation	54
Outlet Operation	54
Vacu-Pass™ Cord & Cable Pass Thru (optional)	55
Working in the Cabinet	56
Planning	56
Cabinet Start-up	56
Wipe Down	56
Loading Materials and Equipment	57
Work Techniques	57
Final Purging	57
Unloading Materials and Equipment	57
Wipe Down	57
Shutdown	58

8: MAINTAINING YOUR AXIOM TYPE C1 **59**

Maintenance Safety Precautions	59
Recommended Maintenance Schedule	60
Service Operations	61
Resetting a Circuit Breaker	61
Center Work Surface Removal	62
Wing Work Surface Removal	63
Center Drip Tray Removal	64

Front Grille Removal	64
Front Panel Removal	65
Changing the LED Lamps	66
Changing the Optional UV Lamp	68
Storage	69

9: ACCESSORIES 70

Telescoping Base Stands	70
Manual or Electric Hydraulic Lift Base Stands	70
SoLo™ Electric Hydraulic Lift Base Stands	71
IV Bar	71
Flat Work Surface	71
Airflow Sensor	72
Bag In Bag Out Exhaust HEPA Filter	72
Sash Prop	73

10: TROUBLESHOOTING 74

Blower and Lights not working	74
Blower only will not start	75
Lights only will not illuminate	76
UV Light will not illuminate	77
Airflow Alert activating	78
Filter Life Gauge not at 100% when new	79
Contamination in the work area	80

APPENDIX A: PARTS LIST 81

APPENDIX B: DIMENSIONS 83

APPENDIX C: SPECIFICATIONS 84

Power Data	84
Motor Specifications	84
Environmental Conditions	85
APPENDIX D: QUICK CHART REFERENCE	86

1: Introduction

Congratulations on the purchase of an Axiom® Type C1 biosafety cabinet. The biosafety cabinet is designed to protect you, the product and the laboratory environment from biohazardous aerosols. It is the result of years of experience in manufacturing laboratory equipment, and users like you suggested many of its features to us.

This biosafety cabinet offers many unique features. To take full advantage of them, please acquaint yourself with this manual and keep it handy for future reference.

About This Manual

This manual is written for the installer and user of this product. For detailed service, certification, or technical information, please utilize the Technical Manual located on the website labconco.com.



This manual contains important operation and safety information. When you see a symbol, such as the INFO symbol to the left, pay close attention to the information provided. Before installing or operating this product, you must read [Section 3: Safety Precautions](#).

Contents Included

The following items are packaged with the product.

- User's manual thumb drive
- Drain valve assembly and fasteners
- Power cord
- Vacu-Pass™ accessory plug (if option package ordered)

The location of these items and additional details are found in [Section 4: Installation](#).

2: Before You Install

Before you install the product, the site should be prepared for installation. Examine the location where you intend to install it. You must be certain that the area is level and of solid construction. In addition, a dedicated source of electrical power must be located within 10 feet (3 m) of the installation site.

Location Requirements

A biosafety cabinet should be located away from areas of high foot traffic, doors, fans, ventilation registers or vents, chemical fume hoods or other air-handling devices. Any of these may interfere with the airflow patterns in and around the product, and subsequently diminish product and/or personnel protection. All windows in the room should remain closed. Figure 2-1 shows the preferred and alternate locations for this product.

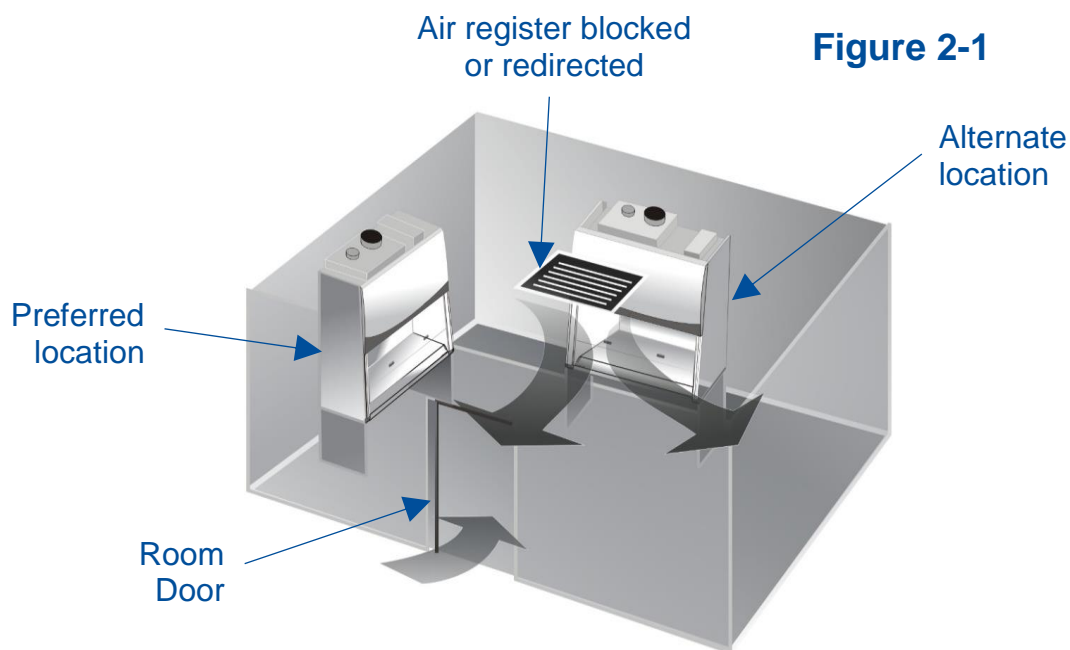

Clearance Requirements

A minimum clearance of at least 6 inches (150 mm) is suggested on the top and both sides of the product for service.

See [Appendix B: Dimensions](#) for overall product dimensions.

Electrical Requirements

The product models have the following electrical requirements.

Catalog Number	Typical Operating Current (Amps)	Electrical Circuit Requirements ¹	
3044xxx01	4 A	115 V, 60 Hz, 16 A	1 Phase
3044xxx21	4 A	100 V, 50/60 Hz, 16 A	1 Phase
3044xxx-11, 31, 41, 51, 61, 71	2 A	230 V, 50/60 Hz, 8 A	1 Phase
3046xxx01	5 A	115 V, 60 Hz, 16 A	1 Phase
3046xxx21	5 A	100 V, 50/60 Hz, 16 A	1 Phase
3046xxx-11, 31, 41, 51, 61, 71	2.5 A	230 V, 50/60 Hz, 8 A	1 Phase

¹ Electrical Requirements, 'V' = VAC (Voltage with alternating current), 'A' = Amperes



A dedicated outlet with an appropriate circuit breaker should be located as close as possible to the product, but no greater than 10 feet (3 m). Consult your local electrical codes for properly rated circuit breakers. For safe operation the dedicated outlet must provide a protective earthing ground connection to the product.



On 100V and 115V models, both internal electrical outlets are protected by a ground fault interrupter circuit (GFI). Labconco does NOT recommend connecting the product's power cord into a GFI outlet. GFI outlets can nuisance trip, resulting in complete removal of power to the product. Such a scenario would result in complete loss of product and/or personnel protection.

Service Line Requirements

All utility service lines should be ¼ inch O.D., brass, copper, or stainless steel, and equipped with an easily accessible shut-off valve. The service valves are rated for operation at 40 PSI (275 kPa). If the service line pressure exceeds this, it must be equipped with a pressure regulator to reduce the line pressure.



Note: The use of flammable gases or solvents should be avoided in the biosafety cabinet. Open flame in the cabinet will disrupt the laminar airflow in the cabinet and may damage the HEPA filters. Flammable gases or solvents may reach explosive concentrations in the cabinet or ductwork. If you feel that the procedure requires the use of an open flame or flammable materials, contact your institution's safety office.



Note: The use of air or gases under high pressure should be avoided as they may seriously disrupt the airflow patterns in the cabinet.

Exhaust Requirements

This product may be connected to a remote (building) exhaust system, when operated as a Type C1 biosafety cabinet in B mode.



Note: Only connect the biosafety cabinet to a suitable exhaust system that is dedicated to the biosafety cabinet, or dedicated to exhausting laboratory ventilation equipment. Do NOT connect the biosafety cabinet to the building's general HVAC system for room exhaust.

Examine the location to ensure that it accommodates the cabinet's exhaust duct. The area directly above the cabinet's exhaust port should be clear of structural elements, water and utility lines, or other fixed obstructions. There should be enough clearance to accommodate a 10-inch diameter duct. See Figure 2-2.

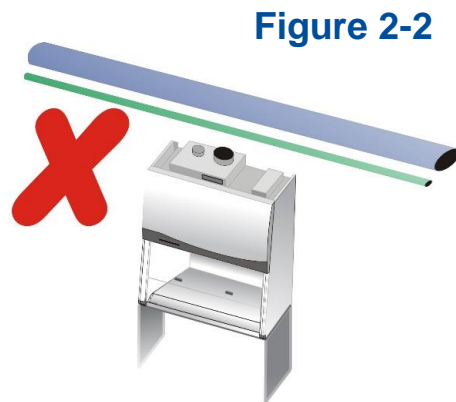

Figure 2-2

Avoid cabinet locations that require an elbow directly above the cabinet's exhaust connection or an excessive number of elbows in the exhaust system. There should be a straight length 10 duct diameters long between the cabinet connection and any elbow, and between subsequent elbows. See Figure 2-3.

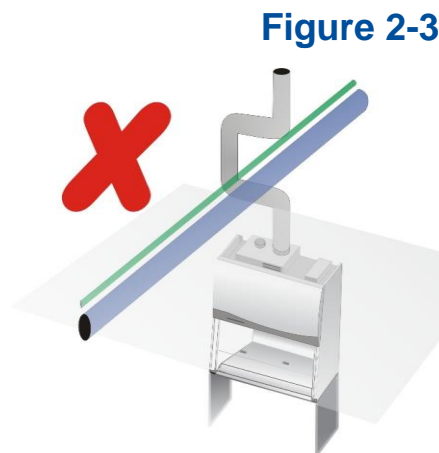

Figure 2-3

The Inlet Relief Valve located on the top of the cabinet is designed to draw a maximum of 100 CFM (170 m³/hr).

Attempting to draw additional room air through the valve (room air exhaust), can result in unstable cabinet operation. See Figure 2-4.



If additional room exhaust needs to be drawn through the exhaust system, install an additional duct and balancing damper downstream of the cabinet's damper. This will allow for proper balancing of the system. See Figure 2-5.

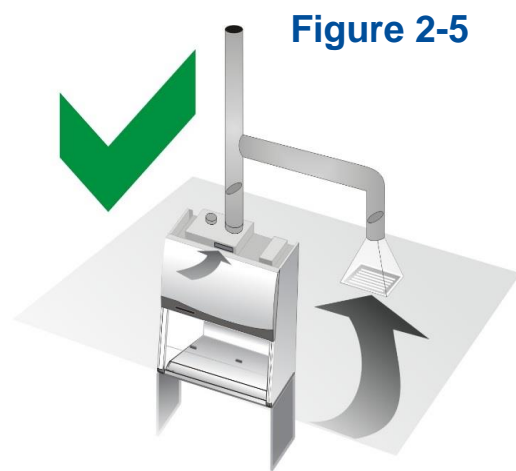

Labconco highly recommends installing an air-tight damper above each biosafety cabinet when connected to a building exhaust system. See *Air-Tight Damper* information on the following page. The air-tight damper allows for fine adjustment of the exhaust air volume provided, in order to correctly set the necessary exhaust airflow for each biosafety cabinet. It also the biosafety cabinet to be sealed off from the building exhaust system, should it become necessary to do so.

The exhaust system must be capable of moving the following volumes of exhaust air at the negative pressures listed. The **Airflow Volumes** are the values recorded via direct measurement using a flow hood at the front opening of the cabinet. The **Concurrent Balance Values** are measured in the exhaust duct via traverse methodology, and will always be higher due to differences in volume measurement methodologies.

Table 2-1

Axiom Type C1 Model	Airflow Volume		Concurrent Balance Value		Recommended Duct Vacuum ¹	
	ft ³ /min	m ³ /hr	ft ³ /min	m ³ /hr	WC ²	Pa
4-foot, 8" Sash	323	549	387	658	0.30	75
4-foot, 10" Sash	400	680	480	816	0.30	75
6-foot, 8" Sash	463	787	556	945	0.30	75
6-foot, 10" Sash	570	968	684	1162	0.30	75

Values are Nominal Inflow (105 fpm) + 50 cfm through Canopy Inlet Relief Valve. CBV = ~ 20% higher

1: Unlike Type B biosafety cabinets, the recommended vacuum will remain constant throughout the life of the exhaust HEPA filter. Duct vacuums below 0.2 inches H₂O (50 Pa) or above 0.5 inches H₂O (125 Pa) may result in erratic operation and throw an alarm condition from the product.

2: WC = Inches of Water Column, typically expressed in units of *inches H₂O*.

Air-Tight Damper

Figure 2-6

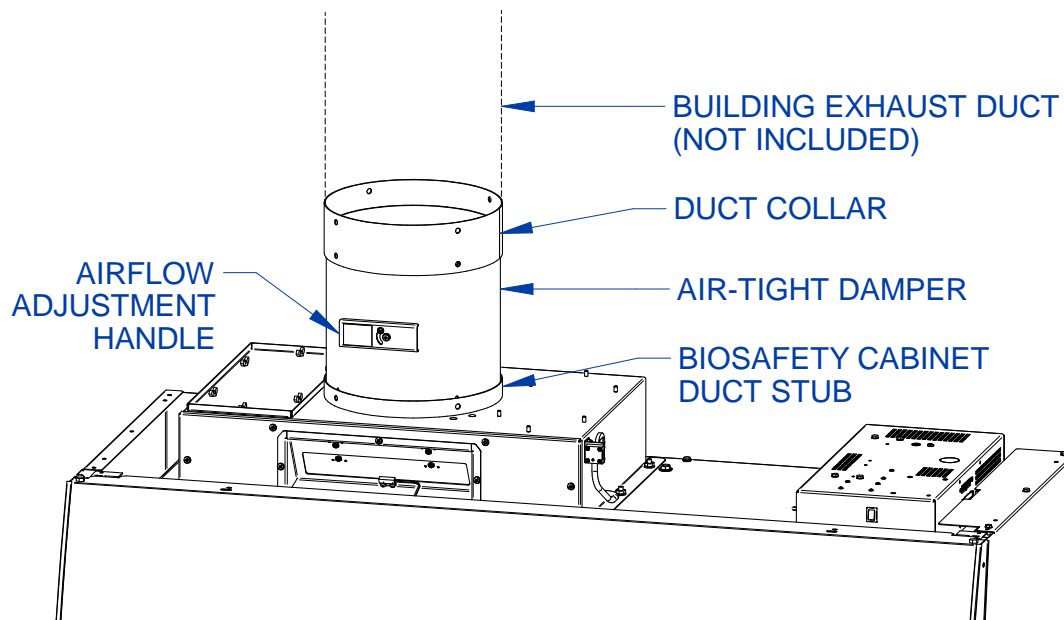

Visual appearance of biosafety cabinet and exhaust connection may vary by model.

3: Safety Precautions

Before unpacking, installing, operating, maintaining, or servicing this equipment, read the following safety warnings and precautions.

Avant le déballage, l'installation, le fonctionnement, l'entretien ou la maintenance de cet équipement, lire les avertissements de sécurité et les précautions d'emploi.



CAUTION – See Manual. When this symbol is on the equipment, it indicates a caution that is detailed in this manual.

MISE EN GARDE – Voir le manuel. Lorsque ce symbole est apposé sur l'équipement, il renvoie à une mise en garde détaillée dans ce manuel.

Typographical Conventions



DANGER – An imminently hazardous situation which, if not avoided, will result in death or serious injury.

DANGER – Situation dangereuse imminente qui, si elle n'est pas évitée, peut entraîner la mort ou des blessures graves.



CAUTION – Indicates a potentially hazardous situation which, if not avoided, may result in minor or moderate injury or damage to property.

MISE EN GARDE – Signale une situation potentiellement dangereuse qui, si elle n'est pas évitée, peut provoquer des blessures mineures à modérées ou des dommages matériels.



NOTE – Advice or suggestions to help the process.

REMARQUE – Conseils ou suggestions pour le déroulement du processus.



BURN RISK (HIGH TEMPERATURE) – Air or components that will be very hot. Take care not to touch these defined areas. Failure to avoid these areas may result in moderate to severe injury.

RISQUE DE BRÛLURE (TEMPÉRATURE ÉLEVÉE) – Air ambiant ou composant devenant très chaud. Veiller à ne pas toucher ces zones délimitées. L'absence de précaution pour éviter ces zones peut entraîner des blessures modérées, voire graves.



EXTREME COLD (LOW TEMPERATURE) – Air or components that will be very COLD. Take care not to touch these defined areas. Failure to avoid these areas may result in moderate to severe injury.

FROID INTENSE (TEMPÉRATURE BASSE) – Air ambiant ou composant devenant très froid. Veiller à ne pas toucher ces zones délimitées. L'absence de précaution pour éviter ces zones peut entraîner des blessures modérées voire graves.



PINCH POINT – Areas or components that can pinch or cut. Take care not to touch these defined areas.

POINT DE PINCEMENT – Zones ou composants présentant un risque de pincement ou de coupure. Veiller à ne pas toucher ces zones délimitées.



MOVING PARTS – Areas or components that contain moving parts. Take care not to touch these defined areas.

PIÈCES MOBILES – Zones ou composants contenant des pièces mobiles. Veiller à ne pas toucher ces zones délimitées.



RISK OF ELECTRICAL SHOCK – The specified procedure or area poses a risk of electrical shock. ALWAYS disconnect main power cord or electrical supply before proceeding.

RISQUE DE CHOC ÉLECTRIQUE – La procédure ou la zone spécifiée présente un risque de choc électrique. TOUJOURS débrancher le cordon d'alimentation secteur ou l'alimentation électrique avant toute intervention.



FLAMMABLE / NO SOLVENTS – Do not place flammable liquids or solvents in this product.

INFLAMMABLE / PAS DE SOLVANTS – Ne placez aucun liquid inflammable dans cette produit.



LIFTING HAZARD – Do not lift or move this equipment without assistance.
DANGER DE LEVAGE – Ne pas soulever ou déplacer cet équipement sans assistance.



MAGNETIC FIELD IN USE – Magnets or magnetic field present.
CHAMP MAGNETIQUE UTILISE – Présence d'aimants ou de champ magnétique.



DO NOT TOUCH – Components or areas indicated are sensitive and will suffer damage if touched. Take care not to touch these defined components or areas. Failure to avoid these areas will result in damage to the product.
NE PAS TOUCHER – Les composants ou les zones indiquées sont sensibles et subiront des dégâts s'ils sont touchés. Veiller à ne pas toucher ces composants ou zones délimité(e)s. L'absence de précaution pour éviter ces zones endommagera le produit.



TOOL REQUIRED – Tool required to access specified area.
OUTIL NÉCESSAIRE – Outil nécessaire pour accéder à la zone spécifiée.

General Safety Precautions

Follow all the safety precautions described in this section.



Before removing any panels which require a tool for removal, **ALWAYS** disconnect the main power cord or electrical supply. Failure to remove all electrical power before proceeding will result in moderate to serious injury, death, or damage to property.

Avant le retrait d'un panneau nécessitant l'utilisation d'un outil, **TOUJOURS** débrancher le cordon d'alimentation secteur ou l'alimentation électrique. Le non-respect de la consigne consistant à couper complètement l'alimentation électrique avant toute intervention peut entraîner des blessures graves, la mort ou des dommages matériels.



Never contact moving parts with your person. Failure to avoid moving parts will result in moderate to serious injury, death, or damage to property.

Ne jamais toucher les parties mobiles. Le non-respect de la consigne consistant à éviter les pièces mobiles peut entraîner des blessures graves, la mort ou des dommages matériels.



Never misuse this product. Never disable, override, or otherwise bypass safety guards, panels, switches, sensors or alarms. Doing so will result in moderate to serious injury, death, or damage to this product or property.

Ne jamais utiliser ce produit à mauvais escient. Ne jamais désactiver, annuler ou contourner les capots, panneaux, interrupteurs, capteurs ou alarmes de sécurité. Ceci entraînerait des blessures graves, la mort ou des dommages matériels à ce produit ou à d'autres biens.



If the unit is not operated as specified in this manual it may impair the protection provided by the unit.

Si l'unité n'est pas utilisée comme spécifié dans ce manuel il peut diminuer la protection fournie par l'unité.



Do not position the unit so that it is difficult to operate the main disconnect device.

Ne placez pas l'appareil de sorte qu'il est difficile de faire fonctionner le dispositif principal de déconnexion.



Do not lift or move this equipment without assistance.

Ne pas soulever ou déplacer cet équipement sans assistance.

Safety Precautions for this Product



Electrical outlets in the cabinet are restricted to 5 amps (100-115v) or 3 amps (230v) maximum current.

Prises électriques dans l'armoire sont limitées à 5 (100-115v) o 3 (230v) courant maximum ampères.



Do not use any detachable power cord that is not adequately rated for the unit.

Ne pas utiliser un fil électrique amovible qui n'est pas du tension nominale de l'appareil.

The biosafety cabinet should be certified by a certification technician before its initial use. The cabinet should be recertified whenever it is relocated, serviced or at least annually thereafter. Filter integrity and airflow performance should be verified before using the cabinet.



Some internal components of the biosafety cabinet may become contaminated during operation of the unit. Only experienced personnel competent in decontamination procedures should decontaminate the cabinet before servicing these components. If you have any questions regarding certification agencies, or need assistance in locating one, contact Labconco's Product Service Department at 800-821-5525 or 816-333-8811.

DO NOT load more than 50 lbs. (23 Kg) in the work area. Exceeding this limit may damage the work surface and its supports. Excessive weight in the cabinet may increase the risk of it overturning, or failure of hydraulic lift stands, resulting in the cabinet and stand overturning. If your application requires loading more than 50 lbs., contact Labconco's Product Service Department at 800-821-5525 or 816-333-8811 for assistance.



Avoid the use of flammable gases or solvents in the biosafety cabinet. Care must be taken to ensure against the concentration of flammable or explosive gases or vapors. An open flame should NOT be used in the biosafety cabinet. Open flames will disrupt airflow patterns, burn the HEPA filter and/or damage the filter's adhesive. Gases under high pressure should not be used in the biosafety cabinet, as they may disrupt its airflow patterns.

HEPA filters only remove particulate matter. Operations generating volatile toxic chemicals or radionuclides must be evaluated carefully.



The media of HEPA filters is fragile and should not be touched. Avoid puncturing either HEPA filter during installation or normal operation. If you suspect that a HEPA filter has been damaged, DO NOT use the cabinet; contact a local certification agency or Labconco at 800-821-5525 or 816-333-8811 for re-certification information.

The HEPA filters in the biosafety cabinet will gradually accumulate airborne particulate matter from the room and from work performed in the cabinet. The rate of accumulation will depend upon the cleanliness of the room air, operating time and the nature of work being done in the cabinet. The Filter Gauge accurately displays the amount of filter life remaining.

Proper operation of the cabinet depends largely upon its location and the operator's work habits. Consult [Section 4: Installation](#) and [Section 7: Using Your Axiom Type C1](#) for further details.

Avoid direct exposure of plastic or coated materials to ultraviolet (UV) radiation. Never bypass the UV safety interlock that only allows the UV light to work when the sash is closed. When surface disinfecting the biosafety cabinet:

- Avoid splashing the disinfecting solution on skin or clothing.
- Ensure adequate ventilation.
- Carefully follow the disinfectant's safety instructions.
- Always dispose of disinfecting solutions in accordance with local and national laws.
- DO NOT allow disinfectants with high concentrations of free chlorine to contact the stainless steel components of the biosafety cabinet for a long period of time. Free chlorine will corrode stainless steel after extended contact.



Biosafety cabinets should be decontaminated for any of the following reasons:

- Before maintenance work requiring entry into contaminated areas.
- Before HEPA filter changes.
- Before performing certification tests requiring entry into contaminated areas.
- Before relocating the cabinet.
- Before changing research programs.
- After the gross spill of biohazardous material or toxic chemicals.

4: Installation

With the installation site properly prepared, you are ready to unpack and install the equipment. This section covers how to:

- Unpack and move the product
- Install the product
- Connect electrical service
- Connect service utilities
- Connect to an exhaust system (optional)
- Arrange certification for the product



A quick reference Installation Guide is located on the front sash glass (see Figure 4-2)

Unpacking



The following tools are required to unpack the equipment:

- Box knife
- #2 Phillips screwdriver
- Two ½” wrenches
- Pliers
- Carpenter’s level



The following safety precautions must be followed by all personnel unpacking the equipment.

- Wear safety glasses
- Wear gloves
- No loose fitting clothes
- Wear close-toed shoes
- Follow safe-lifting practices (do NOT attempt to lift this product without specialized lifting equipment certified to lift up to 1000 lbs.)

Step 1

Carefully remove the outer carton and inspect the product for damage that may have occurred in transit. If the product is damaged, take pictures of the product and the outer packaging, and notify the delivery carrier immediately. Retain the entire shipment, including outer packaging, intact for inspection by the carrier.



Note: United States Interstate Commerce Commission rules require that claims be filed with the delivery carrier within fifteen (15) days of delivery.

Do not return goods without the prior authorization of Labconco. Unauthorized returns will not be accepted.

If the product was damaged in transit, you must file a claim directly with the freight carrier. Labconco Corporation and its dealers are not responsible for shipping damages.

Do not discard the carton or packing material for the product until all of the components have been checked, installed and tested.

The product is secured to the pallet in two places on each side. To access the nuts and bolts holding the product to the pallet, remove the side panels by removing and keeping the two Phillips screws on both panels. Swing the front of each panel away from the cabinet, and lift it straight up to remove the panel from the cabinet. See Figure 4-1.

Figure 4-1

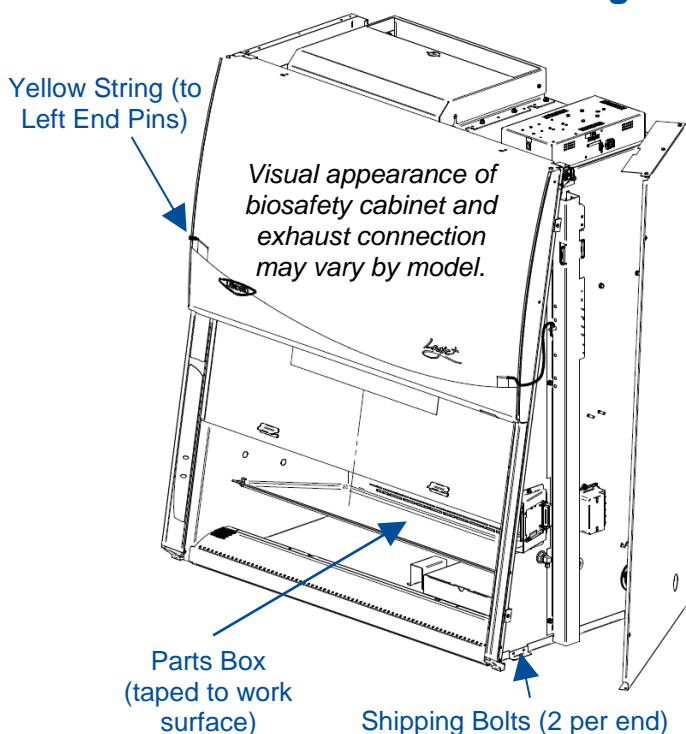

The side panels must be removed to access the fasteners that secure the biosafety cabinet to the pallet. **DO NOT attempt to lift the biosafety cabinet by the side panels; damage will occur.**

Step 2 – Installation on an Existing Work Surface

Move the cabinet, attached to its pallet, by using a floor jack, or a furniture dolly underneath the unit. **DO NOT** move the cabinet by tilting it onto a hand truck.



When lifting the cabinet **DO NOT** lift the cabinet in the middle front area of the hull. Lifting here may bend or distort the bottom of the cabinet, causing damage to the unit.



Note: The cabinet is very top heavy. Use caution when lifting or moving it.

When installing the cabinet onto an existing work surface or benchtop, ensure that the structure can safely support the combined weight of the cabinet and any related equipment. The work surface should be at least as wide as the cabinet and 31 inches (787 mm) deep to properly support the unit. A hole or notch may be cut in the supporting surface in the right front corner to accommodate the optional drain valve.

Step 2 – Installation on a Labconco Base Stand

Move the cabinet, attached to its pallet, by using a floor jack, or a furniture dolly underneath the unit. **DO NOT** move the cabinet by tilting it onto a hand truck.



When lifting the cabinet **DO NOT** lift the cabinet in the middle front area of the hull. Lifting here may bend or distort the bottom of the cabinet, causing damage to the unit.



Note: The cabinet is very top heavy. Use caution when lifting or moving it.

Labconco offers accessory base stands in a variety of configurations to suit your particular needs. If assembly of the base stand is required, the assembly instructions are packaged with the base stand.

Using a mechanical lift, raise the cabinet.

Before setting the cabinet onto the stand, using the four attachment bolts supplied with the stand, align the mounting tab holes on the cabinet with the four holes on the stand's top rail. Drop each bolt through the mounting tab hole and into each hole on the stand's top rail. Carefully lower the cabinet onto the stand. See Figure 4-2.

After the cabinet is in place, remove each attachment bolt, and flip it over to install it up through the stand's top rail, and add the associated washers and nut. Tighten each bolt.

Figure 4-2

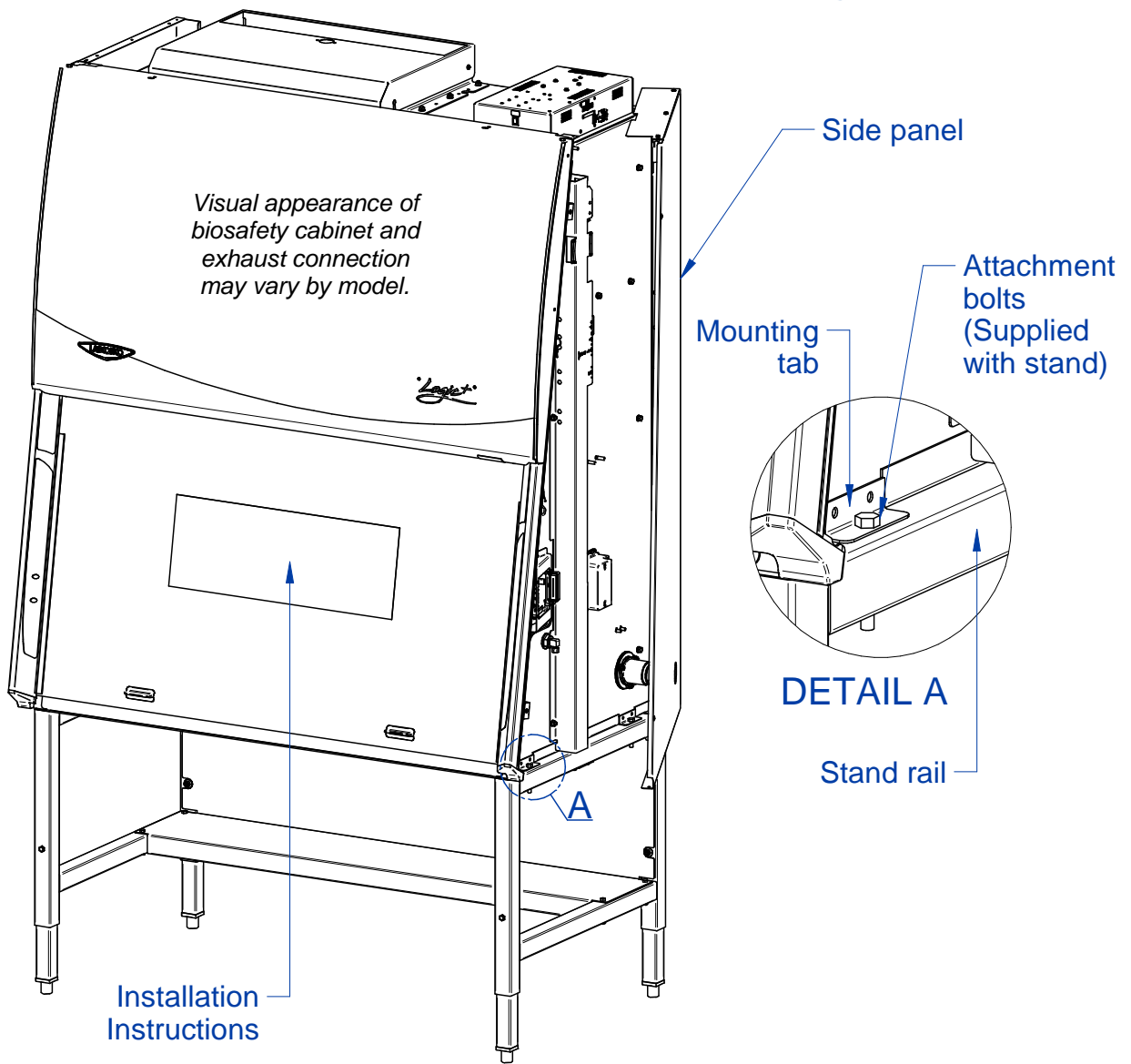

Step 3

The front sash will not slide open yet. The sash counterweights are pinned for shipment. The Side Panels must still be removed or hinged open for this step. Locate the Support Pin and Clevis Pin on each sash counterweight. See Figure 4-3. For convenience a yellow tag and string are provided. Locate each yellow tag on the front of the product, and follow the yellow string to each Clevis Pin. Remove the Clevis Pin (also referred to as a Cotter Pin), then pull the Support Pin toward the rear of the product until it is free. You will hear the counterweight drop a short distance when the Support Pin is removed. Discard the Tags, String, and Pins.

Figure 4-3

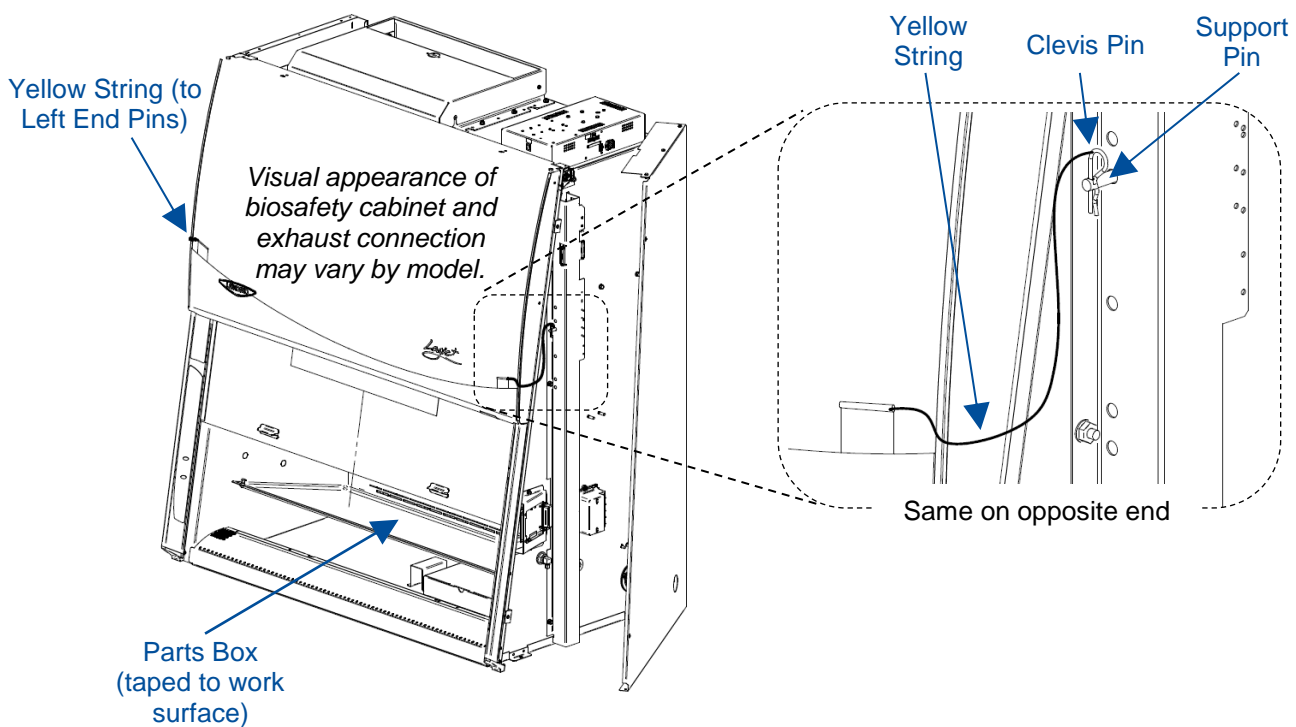

Replace or close each Side Panel and secure the panels with two screws per panel.

Raise the front sash. Locate and retrieve the Parts Box taped to the work surface. See Figure 4-3. The following items are located inside this box.

- User's manual thumb drive
- Drain valve assembly and fasteners
- Power cord
- Vacu-Pass™ accessory plug (if option package ordered)

Electrical Connection

The product's power cord is located in the Parts Box removed in the final step of Unpacking (previous section). Connect the IEC end of the power cord to the IEC connector located on the rear side of the top electrical box. See Figure 4-4. Connect the plug end of the power cord into an appropriately rated outlet (see Electrical Requirements in [Section 2: Before You Install](#)).

Figure 4-4

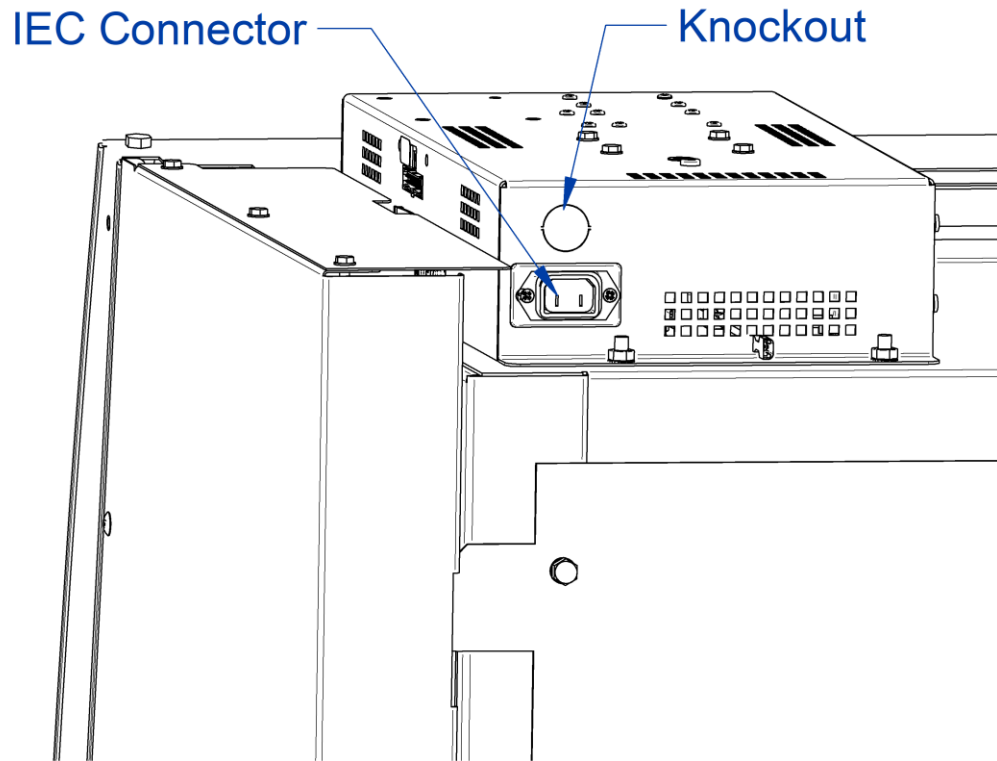

A knockout is also provided in the electrical box to allow for direct wiring of the product. Do NOT attempt to connect power via the knockout or otherwise directly wire the product without consulting your local codes and regulations, and it is highly recommended to utilize a licensed electrician to make this wiring connection. The wiring must meet the minimum gauge requirement for the current specified in [Section 2: Before You Install](#) listed under Electrical Requirements, and must be a dedicated wiring run to a circuit breaker appropriately rated for this product's electrical requirements.

Service Line Connection

Service fixtures are not pre-installed on all models. If your model does not include a service fixture, this step may be skipped. A service fixture can be field installed at any time, the service fixture kit will contain instructions for installing the fixture. Follow the instructions below to make the plumbing connection to the service fixture.



Note: Some models have a solenoid valve connected to the service valve on the right side, rear position. The solenoid prevents gas from flowing to the service valve when the cabinet's blower is off, or there is a loss of electrical power. It is the only service valve position that can be fitted with a solenoid valve. Connect the gas service to the solenoid valve.

The incoming service line(s) should be connected to the tube compression fitting(s) on the outside of the liner wall as shown in Figure 4-5. Open the side panel, then:

1. Ensure that the tubing is $\frac{1}{4}$ inch O.D., soft metal, and that the end has been completely deburred.
2. Route the tubing from the rear of the cabinet, ensuring that it will line up with the slot in the back of the side panel. The slot is located from $8\frac{3}{4}$ to $11\frac{1}{4}$ inches (222 to 288 mm) from the bottom of the cabinet.



Note: Make sure that the tube routing will not contact any electrical wires. DO NOT loop service line tubing within the side panels of the cabinet.

3. Make sure that the nut on the 90 degree tube fitting is loose, but do not remove it. Make sure the tube ferrule is in the fitting.
4. Push the tube into the fitting until it is properly seated. The tube will go approximately $\frac{3}{4}$ inch (19 mm) into the fitting.
5. Tighten the tube fitting nut hand tight and then, using a $\frac{7}{16}$ -inch wrench, tighten it at least $\frac{3}{4}$ turn more.
6. Close the service valve in the cabinet and then slowly open the shutoff valve on the service valve. Test all fittings for leakage. Tighten the tube nut slightly if needed.

Figure 4-5

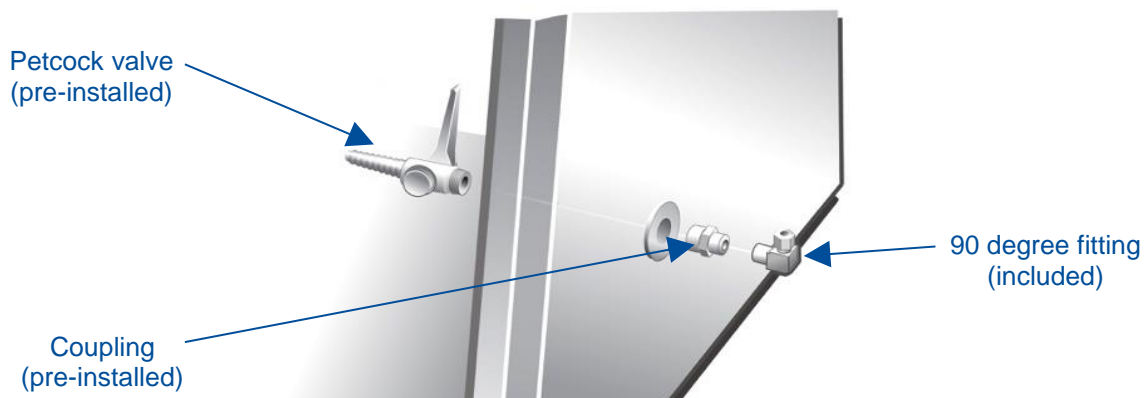

Exhaust Connection



The Axiom Type C1 biosafety cabinet can operate in one of two modes: A-mode or B-mode. When operating in A-mode, the HEPA-filtered exhaust air is recirculated back into the room environment, and therefore does not require an Exhaust Connection. If operating this product in A-mode, this section may be skipped.

The building exhaust system must be capable of exhausting a **constant** volume of air as specified in Table 2-1.



The product ships in the default A-mode. If B-mode operation is desired, once installation of the product is complete, a Certifier must reconfigure the product from A-mode to B-mode in the MyLogic™ Operating System before beginning certification of the product.

Step 1

Remove the exhaust cover panel(s) on the top side of the exhaust cover assembly, and install the panel(s) over the large, rectangular cutout(s) on the exhaust cover. A 4-ft model has one cover panel, a 6-ft model has two cover panels. See Figure 4-6 (4-ft model shown). Reuse the wing nuts and hand-tighten them to secure the cover panel(s).

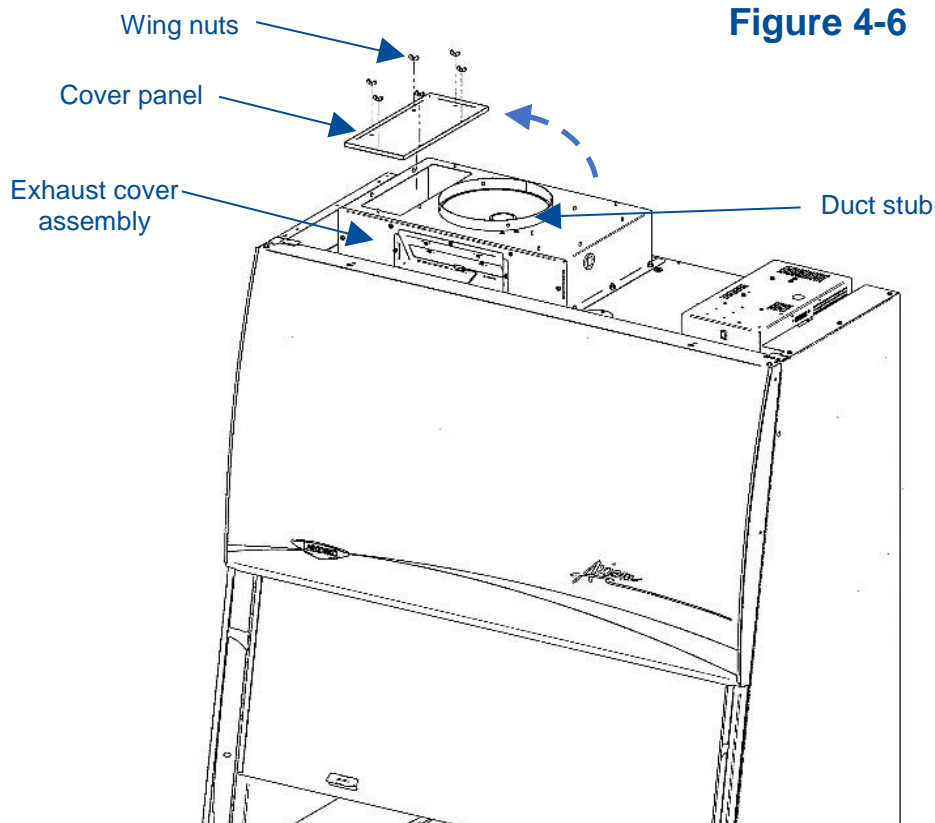

Figure 4-6

Step 2

Connect appropriately rated exhaust ducting to the duct collar provided on the exhaust cover assembly (see Figure 4-6).

The duct collar provided is sized for 10 inch nominal stainless steel duct. The exhaust ducting will rest **INSIDE** the duct collar.



Consult local codes and regulations, as well as the facility's SOP to ensure the exhaust ducting chosen meets all applicable requirements, and is installed to applicable specifications.

The duct collar provides four equally spaced holes through which the exhaust ducting can be mechanically secured. It is recommended to also seal the transition seam between the duct stub and the exhaust ducting with an appropriately rated sealant, such as silicone or polyurethane-based sealant.



An air-tight damper (catalog number 3776800) can be installed into the product's duct stub, and the exhaust ducting connected to the air-tight damper. The damper allows for finer regulation of the exhaust air to the product. It is recommended to install an air-tight damper onto the duct stub of the product.

Step 3

Configure the Axiom Type C1 biosafety cabinet to operate in B-mode. These instructions are found in the Axiom Type C1 Technical Manual.

Drain Valve Installation (Optional)

A drain valve assembly is provided in the Parts Box. The drain allows for removal of large amounts of liquid trapped in the area underneath the work surface. The installation of the drain valve is not required. If not installing the drain valve, this section may be skipped.



Note: The work surface is heavy. Use caution when handling it.

1. Lift the work surface by lifting on the knobs at the front of the work surface wings. Secure the work surface to the rear baffle using the work surface latch. Remove the right work surface wing and locate the cover sealed over the drain mounting holes.
2. Using a putty knife, remove and discard the stainless steel cover that is sealed over the drain mounting holes. Scrape out remaining sealant around the holes.

NOTE: The drain valve assembly attaches to the underside of the cabinet bottom.

3. Apply a light coating of silicone sealant (not provided) to the mounting surface of the drain flange. Attach the drain flange under the bottom of the cabinet as shown in Figure 4-7. Wipe off any excess sealant from the cabinet bottom. Ensure that the center drain hole is unobstructed.
4. Secure the drain assembly with the hardware provided. Tighten all hardware.
5. Make sure the drain valve is in the closed position.
6. Reinstall the work surface components.
7. Allow the silicone sealant to cure for at least eight hours before exposing it to liquid.

Figure 4-7

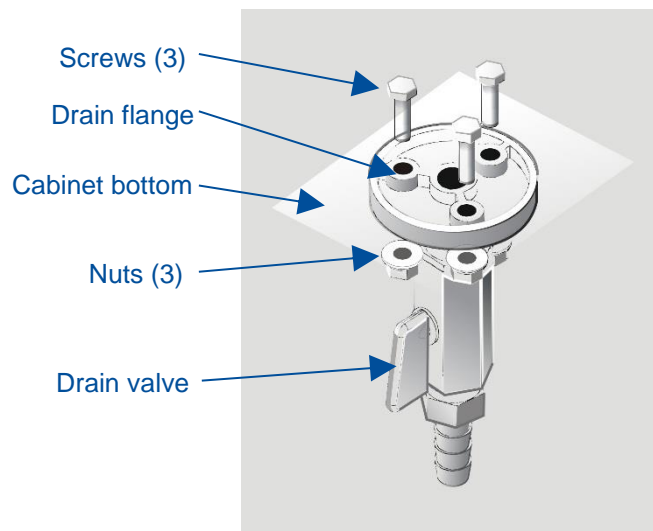

Certification

Prior to use, a qualified certifier should certify a biosafety cabinet. Under normal operating conditions, the cabinet should be recertified at least annually and when relocated or serviced. The certifier should perform the following tests, as recommended in NSF/ANSI Standard Number 49 in effect when the cabinet was manufactured:

- Downflow Velocity Profile Test
- Inflow Velocity Test
- Airflow Smoke Patterns
- HEPA Filter Leak Test
- Optional Canopy Alarm Test and Operation
- Vibration Test *
- Noise Level Test *
- Lighting Intensity Test *

*These tests are user comfort related tests and may be omitted at the user's or certifier's discretion.

If you have any questions regarding certification agencies or help locating one, contact Labconco's Product Service Department at (800) 821-5525 or +1 816-333-8811.

Detailed information for product certification is located in the Axiom Type C1 Technical Manual.

5: Performance Features

The Axiom Type C1 biosafety cabinet protects items placed on the work surface, the personnel working with material inside the cabinet, and the lab environment, when operated to manufacturer's specifications and proper aseptic techniques are employed.

This protection is provided through the use of laminar airflow, HEPA filtration, careful cabinet construction, and Constant Airflow Profile™ (CAP) ECM motors. Each of the key performance features are detailed in this section.

Laminar Airflow

Laminar airflow is defined as the movement of a body of air in a single direction, with a uniform velocity. In practice, the laminar downflow of air in the cabinet captures any aerosol generated in the work area of the cabinet, and directs it to the HEPA filters. In order to be true laminar downflow, a number of individual downflow velocity test points, commonly referred to as the Downflow Velocity Profile, must be +/- 16 feet per minute (0.08 m/s) of the average of all the test points.

Figure 5-1

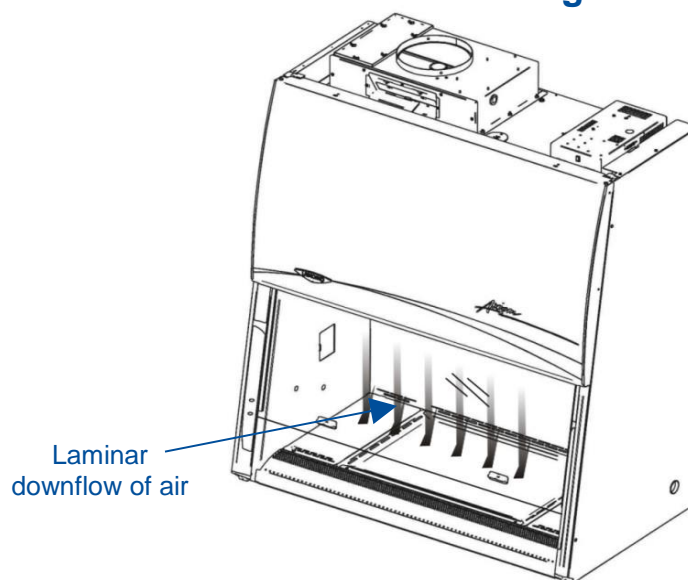

Directional Airflow

Directional airflow also plays a key role in cabinet performance. Air is drawn into the front of the cabinet at the front grille. This “curtain” of air makes it more difficult for aerosols to escape out of the work area of the cabinet and into the outside environment. This airflow is often calculated and referred to as the **Inflow Volume** or **Average Inflow Velocity**. This is illustrated in Figure 5-2.

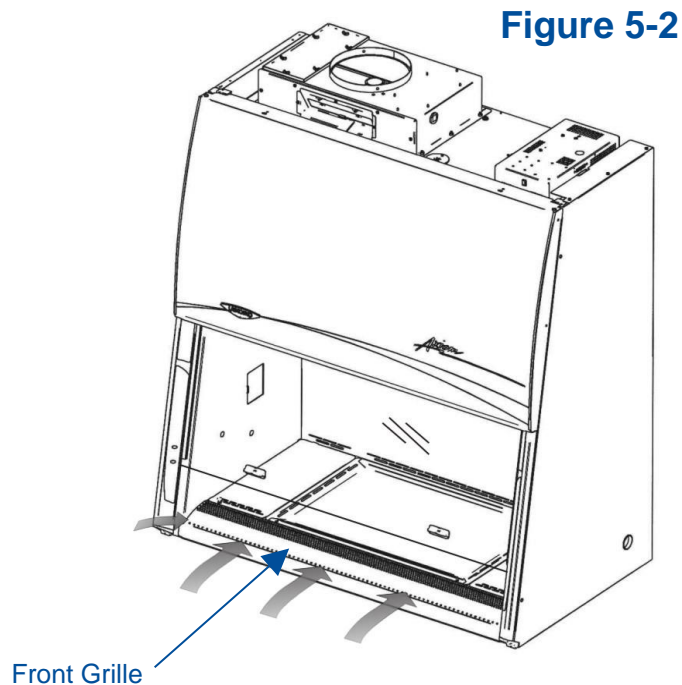

Cabinet Air Intake (Front Grille)

The location, size, and pattern of the grille openings in the work area affect cabinet containment and performance. The front grille’s airfoil profile, and air intake openings play an important role in establishing Directional Airflow, as described previously. See Figure 5-2.



Note: Do not block or obstruct the grille openings of the biosafety cabinet.

Chem-Zone™ Directly Exhausted Work Zone

Unique to the Axiom is the Chem-Zone, a directly exhausted work zone. The central portion of the work surface is surrounded by grilles on the sides, front and back. Air entering these grilles is drawn to the Exhaust HEPA filter, and when the cabinet is in B-mode and connected to an exhaust system, out of the laboratory. This feature prevents the recirculation of volatile chemicals as seen in Type A cabinets, while exhausting much less air than Type B2 models. This is illustrated in Figure 5-3.

Figure 5-3

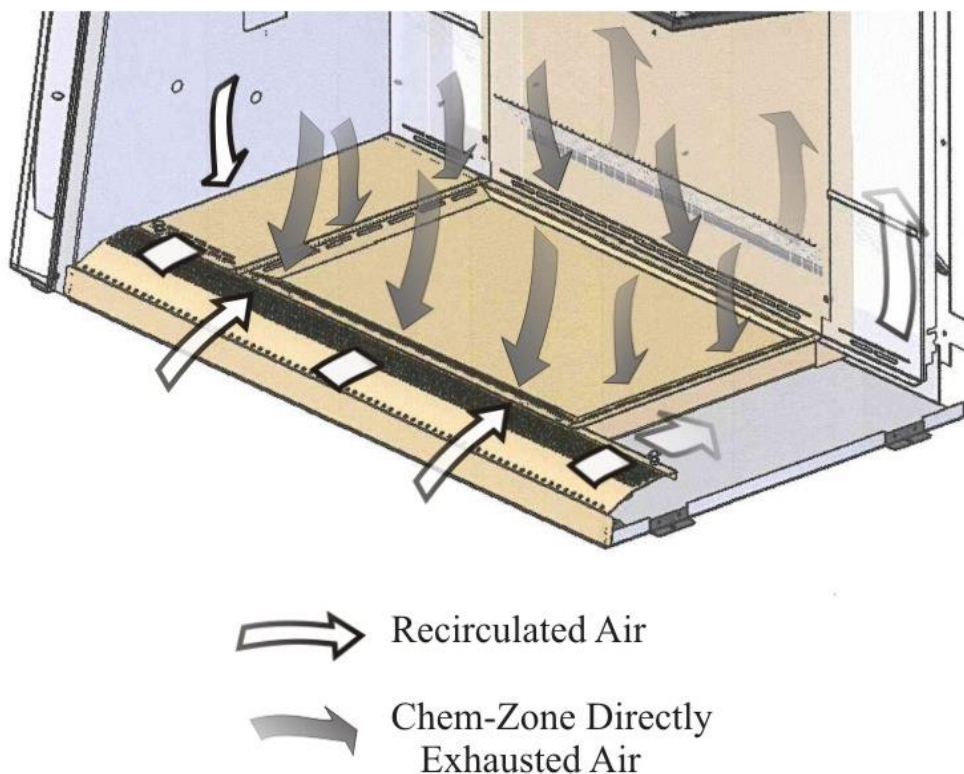

HEPA Filters

HEPA filters are disposable, dry-type particulate filters. The filter material or media is typically made of borosilicate microfibers formed into a thin sheet, in a process similar to the production of paper. This sheet is folded, or pleated to increase its surface area. The pleats are typically held in place by beads of glue that add rigidity to the media pack. The pack is then set into a frame, and sealed as shown in Figure 5-4.

The HEPA filter manufacturer establishes the efficiency of the filter by challenging it with an aerosol of known particle size. The number of particles that penetrate the filter are

quantified, and this establishes the efficiency of the filter. The HEPA filters used in the Axiom are at least 99.99% efficient in removing particles 0.3 micron.

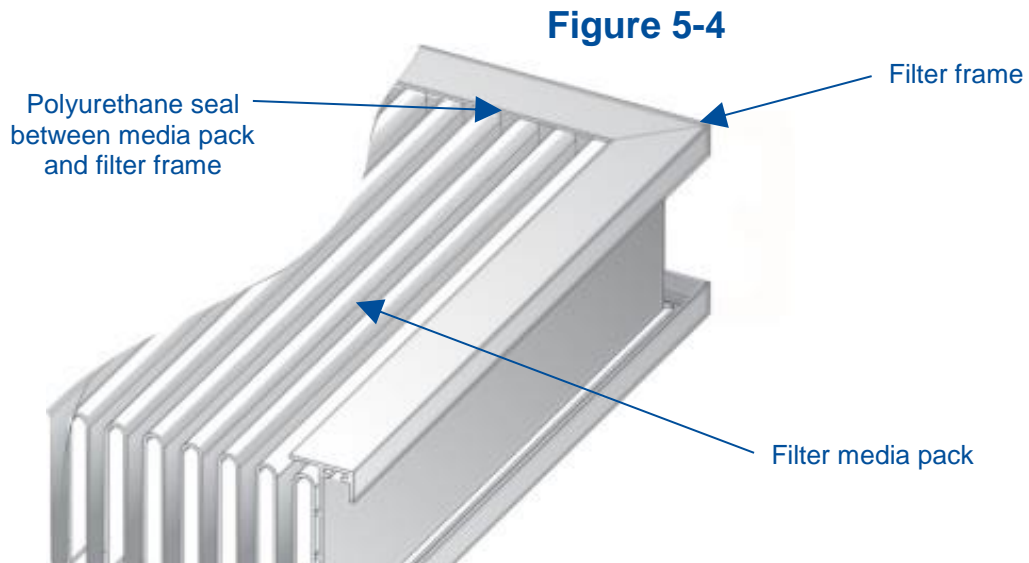

Note: The HEPA filter media is very fragile. DO NOT touch the media. If you think the media of a HEPA filter is damaged, DO NOT USE THE CABINET. Have the HEPA filter integrity tested by a certifier before using the cabinet.



Note: HEPA Filters are only effective against particulate material. Gases and vapors will pass through the filter.

ULPA Filters

Optional ULPA filters may be used to replace the standard HEPA filters in the Axiom. ULPA filters have the same properties as described above except they are rated at least 99.999% efficient in removing particles 0.1-0.2 or 0.2-0.3 micron in size.

Motor/Blower

Unlike some Biosafety Cabinets, the Axiom has two motor/blowers. The supply motor/blower is positioned above the Supply HEPA filter, and is responsible for the recirculation of air from the front grille and sides of the work area back down and over the work area. The exhaust motor/blower is located before the exhaust HEPA filter, and it draws the air in the center of the work area, and pushes it through the exhaust filter, discharging HEPA-filtered air either back into the laboratory, or into an exhaust system. See Figure 5-5. Both motors in the Axiom cabinet are electronically commutated motors (ECM). The ECM is a brushless DC motor that includes its own power supply to convert the incoming alternating current to direct current, as well as its own microprocessor to control and measure the motor's operation. The motors utilize Labconco's exclusive Constant Airflow Profile™ (CAP) programming to deliver a consistent volume of air, throughout the life of the HEPA filters.

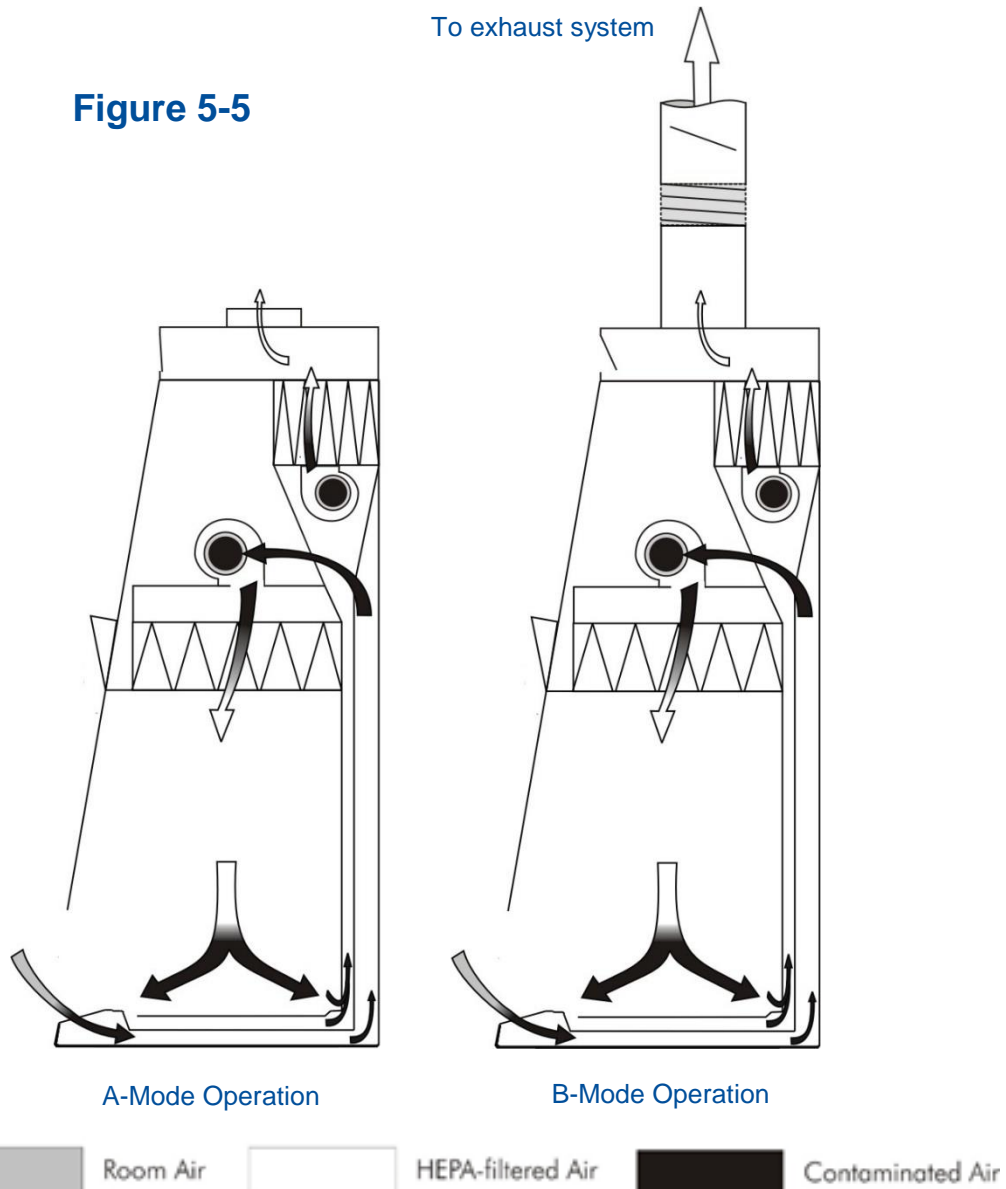

UV Lamp (optional)

The optional UV lamp generates a primary wavelength of light of 254nm. A secondary emission is in the visible (blue) wavelength, resulting in the characteristic blue color while operating. UV light at this wavelength is biocidal, primarily by creating thymine dimers in DNA. These dimers prevent the correct transcription of the DNA into RNA, resulting in cellular death or viral inactivation. In order to be effective, the UV light must directly strike the nucleic acid, and its effectiveness can be diminished or negated by dissolved proteins or metals, or by other UV-opaque substances protecting the target nucleic acid.

Because of its limitations, UV light should be used as an adjunct to good surface disinfection practices. In order to achieve optimum performance from the UV lamp, it should be replaced after 6,000 hours of operation or less, and the exterior surface of the lamp should be kept clean and free of dust.



Note: The Axiom records the number of hours of operation of the UV light. You can program in the number of hours (in 100-hour increments) it will operate before a replacement message is displayed.



Note: UV irradiation is absorbed by the tempered safety glass of the sash. Independent research has shown that the level of UV irradiation on the outside of the cabinet's sash is equal to background radiation levels.



Note: The UV sensitivity of a target organism varies, depending on the UV output of the lamp, the genus and species of the organism, the medium the agent is suspended in, etc. Contact the Health and Safety Officer at your facility for UV light use and recommendations.

6: MyLogic™ Operating System

The Axiom Type C1 biosafety cabinet features the MyLogic operating system, which provides clear status information on the LCD display and user control with the keypad (Figures 6-1 & 6-3). Read this section along with [Section 7: Using Your Axiom Type C1](#) to fully understand the features and controls of this product.

Home Screen

The Home Screen will display the following information (Figure 6-1).

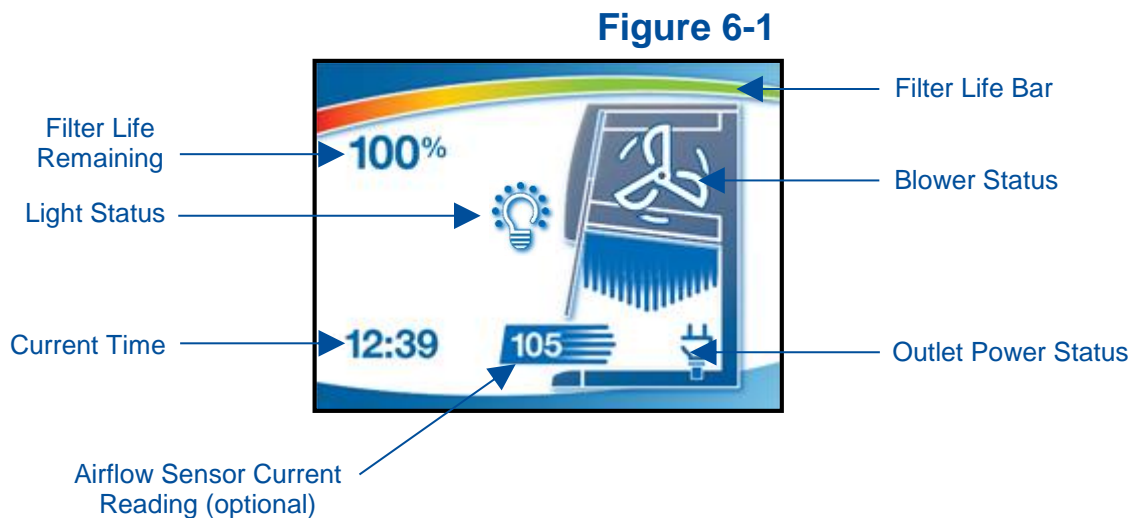

When the glass sash is closed, the blower and light icons may change as follows:



Blower Status = Reduced Speed
(NightSmart Enabled)



Light Status = UV Light ON

27

← UV Countdown Timer (minutes)

Display Sleep Mode

The LCD display will enter sleep mode when the blower is off (Figure 6-2). If the blower is not turned on, and no keys are pressed on the keypad, after 5 minutes the screen will automatically turn off to relax the LCD display, which extends its life. When the display transitions from sleep mode to off, the screen will appear black. Any key press will wake the screen and return to the Home Screen.

Figure 6-2



Keypad

The Keypad button functions are explained in detail in [Section 7: Using Your Axiom Type C1](#), under the subsection Keypad. A summary description is provided here with Figure 6-3.

Figure 6-3

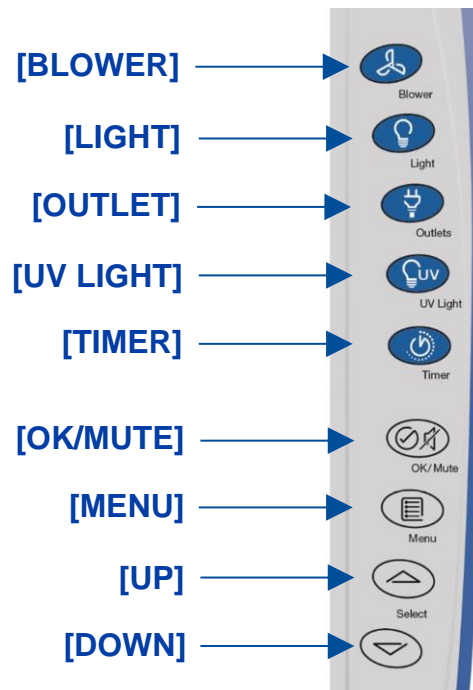

Main Menu



Keypad button presses are shown as **[BLUE WITH BRACKETS]**. Menu screen selections are shown as *green italics*.

To access the Main Menu from the Home Screen, press **[MENU]** on the keypad. See Figure 6-4. The display will change to the Main Menu. To return to the Home Screen, press **[MENU]**.

Figure 6-4

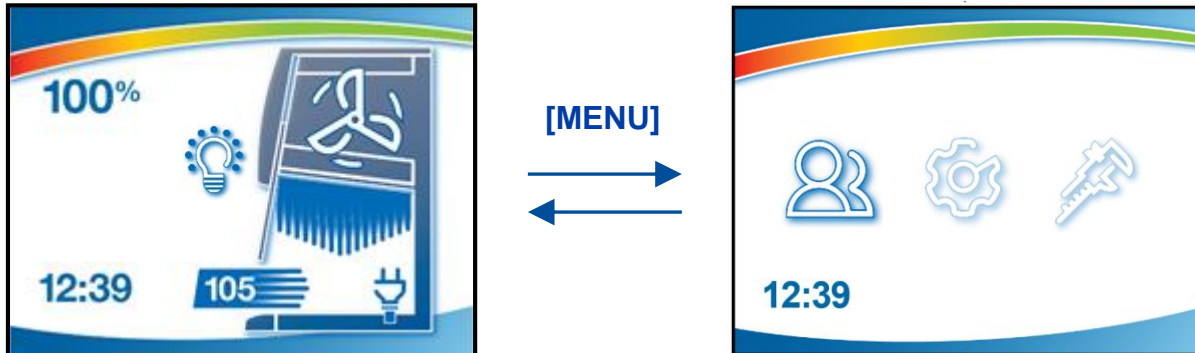

Note – Inflow displayed only when optional airflow sensor installed

The Main Menu displays three submenu options, as shown in Figure 6-5. To select from the various submenu options, press the **[UP]** or **[DOWN]** buttons until the selected option is highlighted. Press **[OK/MUTE]** to accept that option, or press **[MENU]** to return to the Home Screen.

Figure 6-5

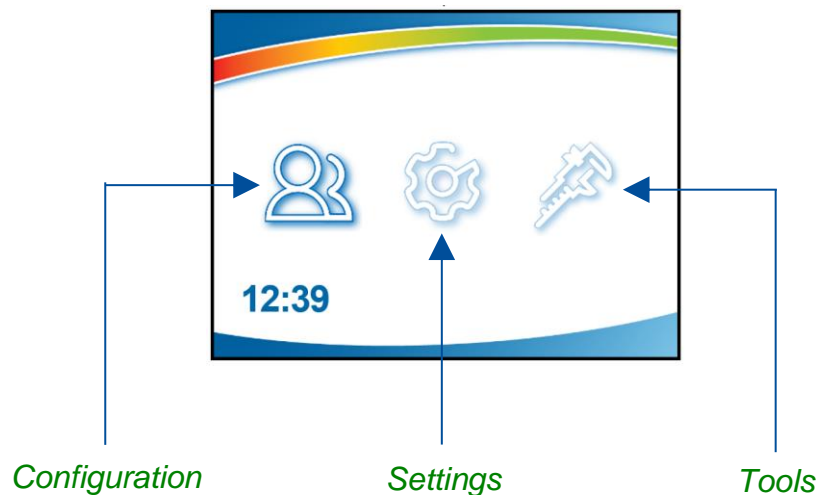

Configuration Submenu



Keypad button presses are shown as **[BLUE WITH BRACKETS]**. Menu screen selections are shown as *green italics*.

This submenu allows you to set preferences for audible tones, set the language, set the clock, and configure how the unit operates when the sash is opened or closed (SmartStart™ / NightSmart™).

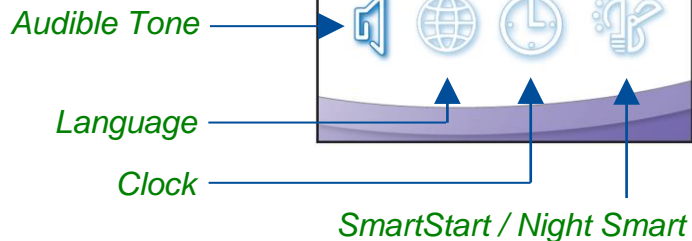

Figure 6-6

Audible Tones

When enabled, an audible tone will sound during cabinet power up. This also enables or disables audible tones from the keypad (any button press).



Audible tones associated with alarms cannot be muted.



Figure 6-7

Selecting a Language

[UP] and **[DOWN]** will move among the selectable language options. When the desired language is highlighted, press **[OK/MUTE]**. Language options:

<i>English</i>	<i>Spanish</i>
<i>French</i>	<i>Italian</i>
<i>German</i>	<i>Portuguese</i>
<i>Chinese</i>	<i>Japanese</i>



Figure 6-8

Setting the Clock

Select either *12 Hour* (AM/PM) format or *24 Hour* format.

Figure 6-9



[OK/MUTE]

Figure 6-10



The selected field (*Hours* or *Minutes*) flashes, set the current time using [UP] and [DOWN]. *Hours* will flash first, once correct, use [OK/MUTE] to switch to *Minutes*. Holding [UP] and [DOWN] in the *Minutes* field will fast scroll.

Note: AM or PM will not show if *24 Hour* format selected.

Setting Automatic Operation Options (Nightsmart™ / SmartStart™)

The cabinet allows configuration to activate functions automatically when the sash is opened or closed. The following screens will display sequentially with **[OK/Mute]**.

The first screen provides the option of activating the blower; if you want the cabinet blower to start every time you raise the sash, select *Blower On*, and then **[OK/Mute]**. If *Blower Off* is selected, the blower must be manually started from the keypad. When **[OK/Mute]** is pressed, the next configuration screen will appear.

Figure 6-11

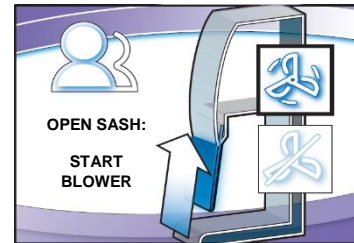

If you want the cabinet blower to run slowly, maintaining reduced airflows every time you close the sash, select *Reduced Speed* and then **[OK/Mute]**. If *Blower Off* is selected, the blower will stop when the sash is closed. When **[OK/Mute]** is pressed, the next configuration screen will appear.

Figure 6-12

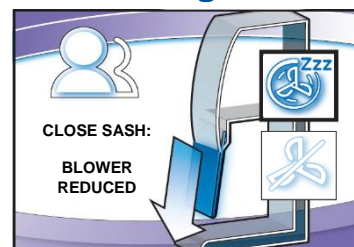

If you want the cabinet lights to turn on every time the sash is opened, select *Light On*, and then **[OK/Mute]**. If *Light Off* is selected, the lights must be manually illuminated from the keypad. When **[OK/Mute]** is pressed, the next configuration screen will appear if the cabinet is configured for a UV lamp.

Figure 6-13



If your Cabinet is configured for a UV light, you will see Fig. 6-14 and 6-15. If you want the UV lamp to turn on every time the sash is closed, select *UV Light On*, and press **[OK/Mute]**. If *UV Light Off* is selected, the UV light will not turn on when the sash is closed. When **[OK/Mute]** is pressed, the final configuration screen will appear.

Figure 6-14

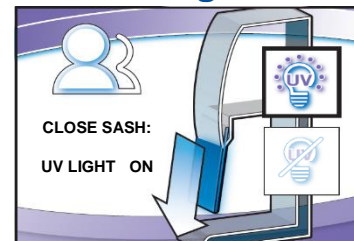

Whether the UV Light is initiated from the **[UV Light]** button on the keypad, or automatically initiated upon closing of the sash, this screen controls the time the UV lamp will remain on. Select the length of time desired, press **[OK/Mute]**.

Figure 6-15

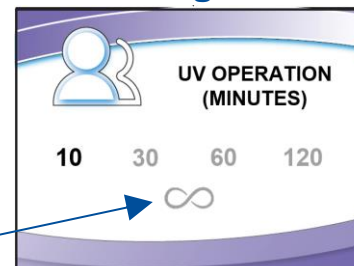

Continuous On

Navigating the Settings Submenu



Keypad button presses are shown as **[BLUE WITH BRACKETS]**. Menu screen selections are shown as *green italics*.

This submenu allows you to select: *Units of Measure*, *System Lock*, *Data Output*, or *UV Parameters*.

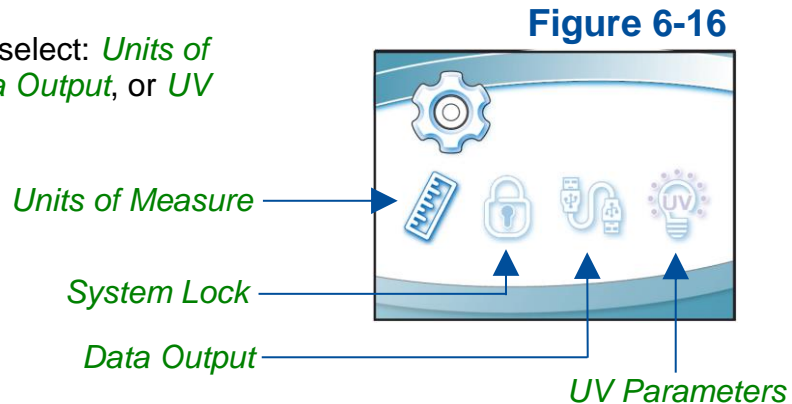

Selecting the Units of Measure

If your cabinet is equipped with an airflow sensor, the units of measure can be set for *FT/MIN* (feet per minute) or *M/S* (meters per second). Select the appropriate units of measure, then **[OK/Mute]**.

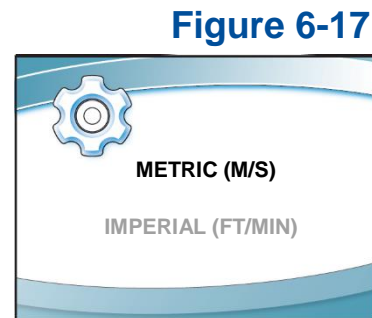

Activating the Security Lock

The Security Lock “locks” the keypad to prevent unauthorized use of the cabinet. To enable / disable select *Protected / Unprotected*, then **[OK/MUTE]**. When enabled, the keypad is locked immediately after the blower is turned off. The security lock is deactivated by holding **[DOWN]** for three seconds. If blower is not turned on within 5 minutes of unlocking, the keypad will relock. The feature remains enabled until it is disabled in this screen.

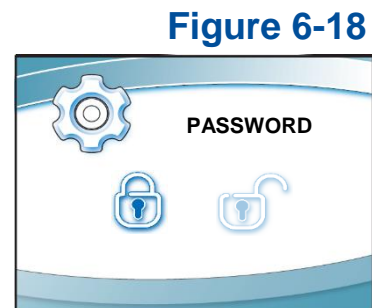

Setting the USB Output Rate

This menu option selects the rate that cabinet status data is exported out of the mini USB port on the side of the top electrical box. Data can output at a rate of *once per second*, *once per 10 seconds*, *once per 30 seconds*, or *once per 60 seconds*. Make the appropriate selection, then **[OK/MUTE]**.

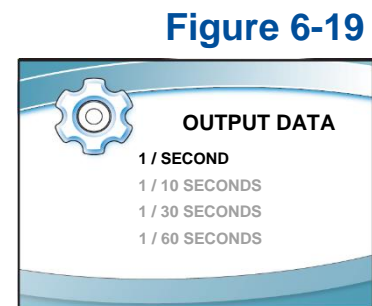

UV Parameters

For models equipped with the optional UV light, the cabinet has an integral UV light maintenance system. It allows you to monitor how many hours the lamp has been on, to reset the UV lamp hourmeter, and to define how many hours you want the UV lamp to operate before receiving a reminder to replace it.

This screen displays the hours of UV lamp operation (Runtime), and how many hours remain (Remaining) until you receive a warning to replace the lamp. To reset the Runtime hourmeter to zero (after replacing the UV lamp), select *Reset*, then **[OK/MUTE]**. The hour text will begin to flash, if you entered this condition by mistake, press **[MENU]**. If you want to reset the hourmeter, hold **[OK/MUTE]** for 3 seconds.

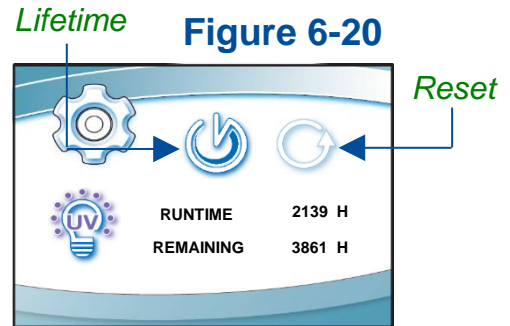

To change the desired UV lamp lifetime, select *Lifetime* as seen in Fig. 6-20, then **[OK/MUTE]**. The screen shown in Fig. 6-21 will display. To change the UV lamp lifetime (number of operating hours before receiving a warning), change the *Hour* field accordingly using **[UP]** or **[DOWN]**, then **[OK/MUTE]**.

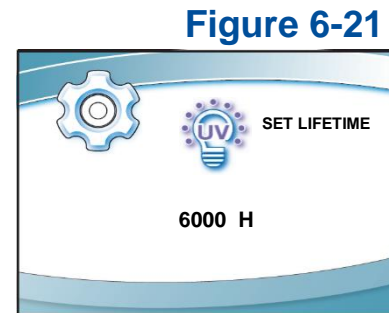

For most UV lamps, the output of UV light decreases at a constant rate. Typically, after 6,000 hours of operation the lamp's output intensity will reduce to 80% of when it was new. This option allows you to set operational life of the UV lamp, in 100 hour increments. 6,000 hours is the default.

The Tools Submenu

This submenu is reserved for use by certifiers, during certification or service procedures. **CAUTION!** - Entering this submenu will disable some alarms and functionality so that diagnostic and certification procedures can be performed.

Additional details on the Tools Submenu are found in the Axiom Type C1 Technical Manual.

Timer Operation

The timer allows activation of an interval (countdown) or elapsed (stopwatch) timer. The timers cannot be operated simultaneously.



Keypad button presses are shown as **[BLUE WITH BRACKETS]**. Menu screen selections are shown as *green italics*.

To access the Timer Menu, press **[Timer]** anytime during normal operation (from the Home Screen). The Timer Menu is displayed (Figure 6-22). Select *Interval* or *Stopwatch* Timer, then **[OK/MUTE]**.

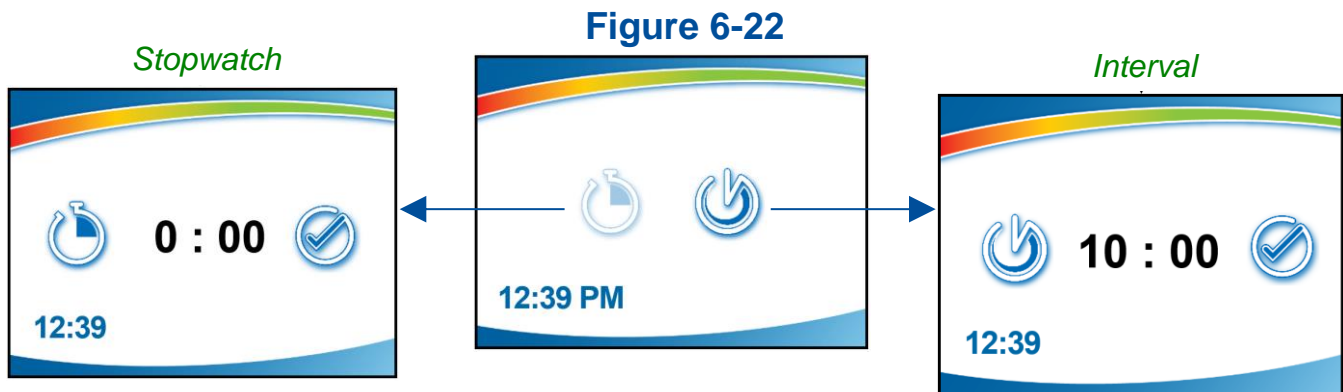

Interval Timer Operation

1. The interval timer defaults to 05:00 (minutes:seconds).
2. Press **[UP]** or **[DOWN]** to increase or decrease the timer interval.
3. When the proper interval is selected, press **[OK/Mute]** to start the timer.
4. When the timer reaches 00:00, an audible alarm will sound.
5. Press **[OK/Mute]** to pause the timer. Press **[OK/Mute]** while paused, and the timer will reset to the previously selected interval.
6. Press **[Menu]** to clear the interval timer and return to the main timer menu.

Stopwatch Timer Operation

1. The stopwatch timer defaults to 00:00.
2. Press **[OK/Mute]** to start the timer.
3. Press **[OK/Mute]** again to pause the timer. Press **[OK/Mute]** while paused, and the timer will reset to 00:00.
4. Press **[Menu]** to return to the main timer menu.

Airflow Alert

While the blower is on, any sudden disruption to the airflow within the cabinet will trigger an Airflow Alert. When an Airflow Alert activates, the display will automatically change (Figure 6-23), and the audible alert tone will sound.

The most common causes of an Airflow Alert are:

- Blockage of the inlet grilles or exhaust outlet
- Removal of the work surface or grille during operation

Look to identify the cause of the airflow disruption, and remove the blockage or return the work surface to its proper position.

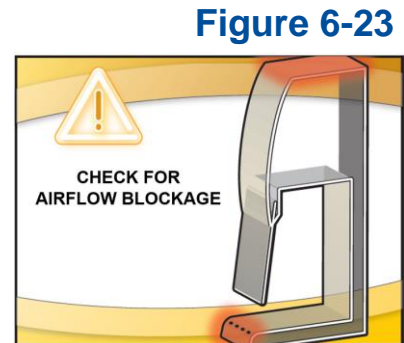

When a blockage of the airflow occurs, the cabinet's blower automatically increases its speed to maintain constant volume airflow. This is a protective feature; however, if the disruption is significant (for example blocking the entire front grille) it will not guarantee product or personnel protection remains during the significant blockage event.

Resetting the Airflow Alert System

The Airflow Alert automatically dismisses once the motor speed has stabilized.



Note: Once the blockage or disruption has been resolved, the Airflow Alert may reactivate while the blower returns to correct operating speed. It will dismiss automatically once the blower reaches correct operating speed.

Alarms

Any alarm that activates requires the user's immediate attention, and some form of actionable response to clear the alarm.

Power Loss Alarm

The cabinet has lost power. See Figure 6-24. Press **[OK]** on the keypad to acknowledge that a power loss occurred.



Note: This alarm will activate any time power is cycled, including turning the System Reset Switch (see Figure 7-2) off and back on.

Figure 6-24



Sash Height Alarm

The sash is not at the proper operating height. Return sash to proper working height.

Figure 6-25



Blower Failure Alarm

The blower motor has failed, or the motor and display circuit board are not communicating properly. Press **[BLOWER]** on the keypad to clear the alarm.

The Axiom Type C1 has two internal blowers. If the failed blower is the supply blower, **SUPPLY** will display. If the failed blower is the exhaust blower, **EXHAUST** will display.

EXHAUST

Figure 6-26

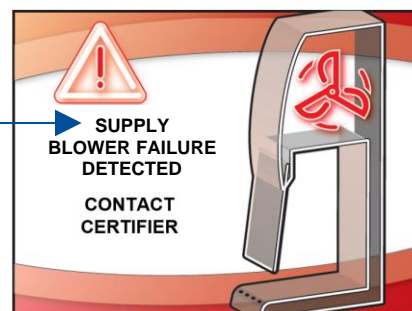

DO NOT USE THE CABINET UNTIL THE PROBLEM HAS BEEN CORRECTED.

The previous Alarms (Power Loss, Sash Height, and Blower Failure) can occur on any Axiom Type C1 cabinet whether it is operating in A-mode or B-mode.

The following Alarms will only occur on the Axiom Type C1 cabinet when operating in B-mode, as these alarms are only related to build exhaust problems.

Exhaust Airflow Check

This is not an Alarm. When operating in B-mode, and the blower is turned on, the cabinet will wait 1 minute until proper building exhaust airflow is established before turning on the cabinet's internal blowers. During this waiting period, the display will show Figure 6-27.

Figure 6-27

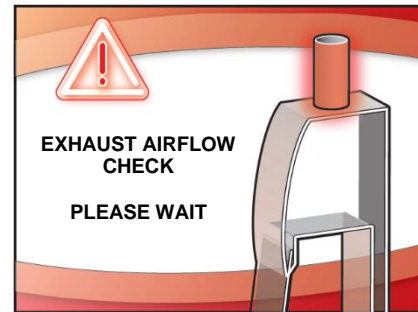

Starting Exhaust Alarm

When operating in B-mode, and sufficient building exhaust airflow is never achieved during the 1 minute blower starting period, this alarm will be displayed. Press **[BLOWER]** on the keypad to clear the alarm.

Figure 6-28

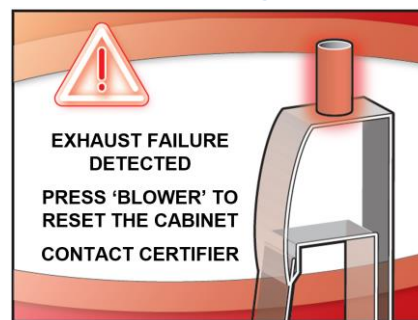

Running Exhaust Alarm – Active Protection

When operating in B-mode, after the blowers are successfully started, and the building exhaust airflow drops below the minimum safe level, this alarm will be displayed.

Once this alarm activates, the cabinet's blowers will continue to run - maintaining safe airflow in the cabinet for the **Active Protection** time (up to 5 minutes) selected in the Tools Submenu.

Figure 6-29

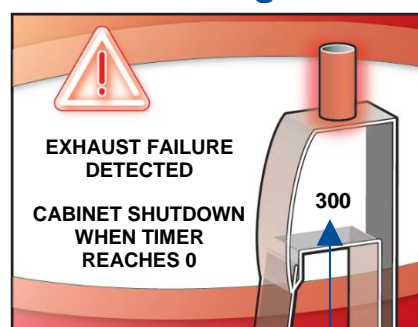

Countdown timer for Active Protection

Press **[BLOWER]** on the keypad to clear the alarm.

Overdriven Exhaust Alarm

When operating in B-mode, and the building exhaust airflow is too high, this alarm will be displayed. All blowers will automatically be turned off if this alarm condition occurs. Press **[BLOWER]** on the keypad to clear the alarm.

Figure 6-30



7: Using Your Axiom Type C1

This section details the functional features and proper techniques for safely and efficiently using the Axiom Type C1 biosafety cabinet.

Feature Overview

Figure 7-1 illustrates key features and components of the product.

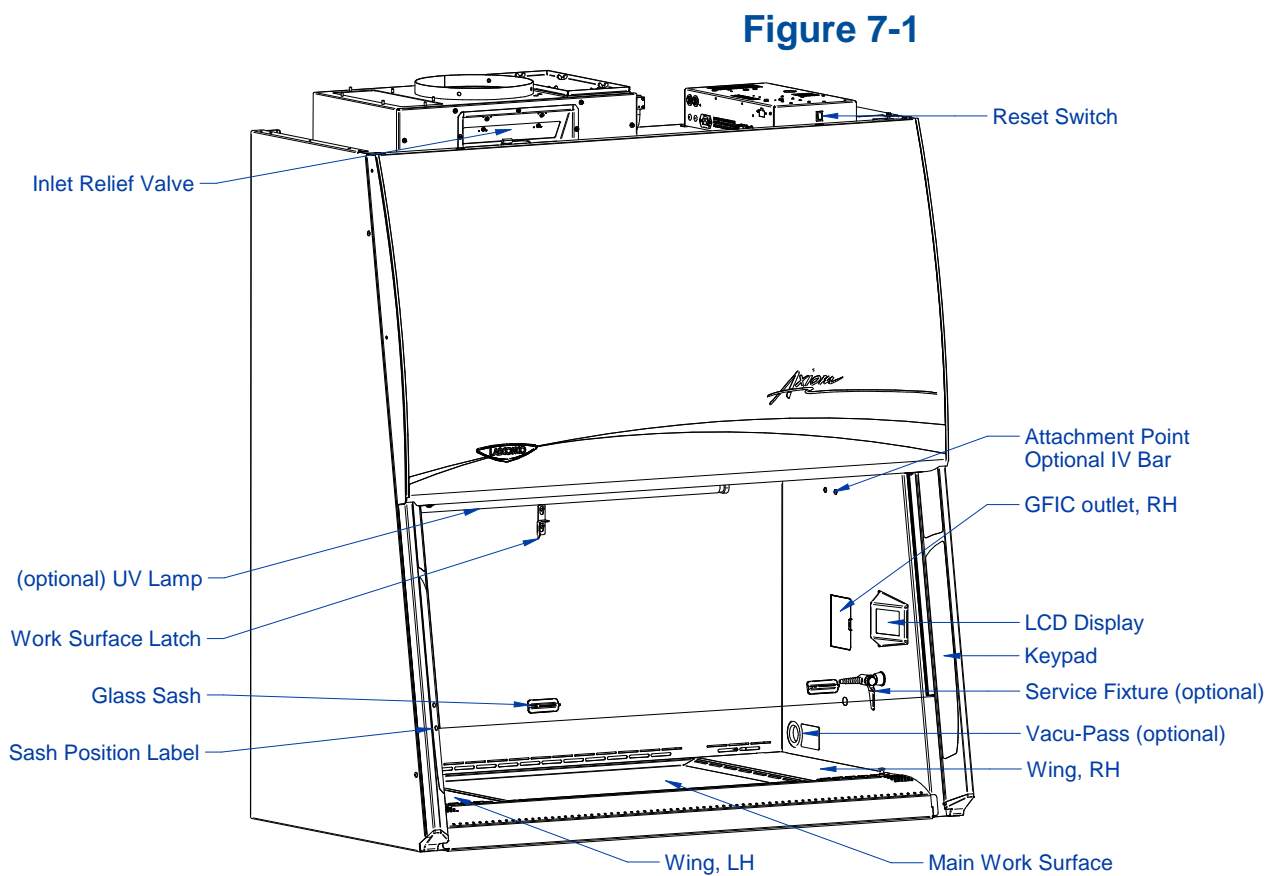

System Reset Switch

The system reset switch removes power from the control board and microprocessor. It is located on the front side of the electrical box on the top, right side of the product. See Figure 7-2. This switch will NOT remove all electrical power from the product. For service operations, always disconnect the main electrical connection prior to removing service panels.

Figure 7-2

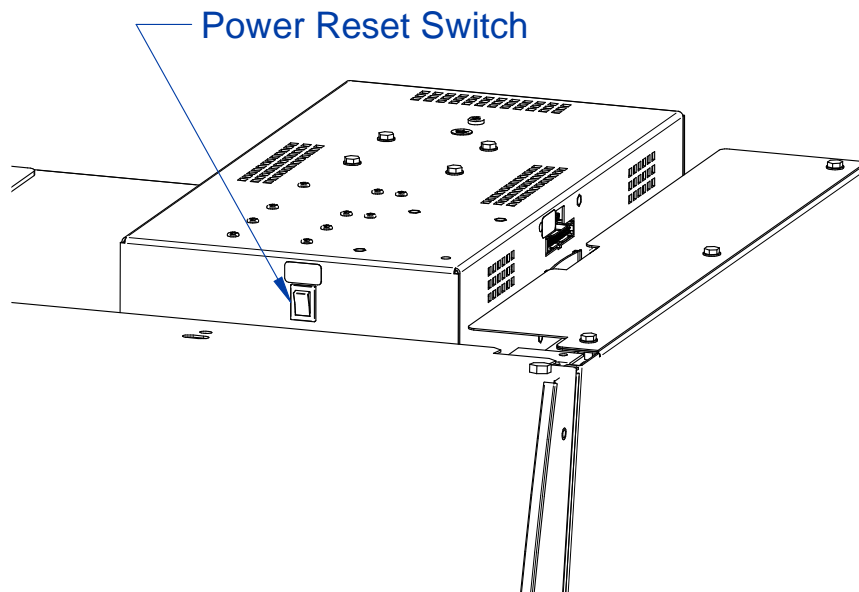

Keypad

The keypad of the cabinet is shown in Figure 7-3. Take a moment to familiarize yourself with the buttons, their locations and functions. Also familiarize yourself with the display located on the right side wall. The display will report system functions, such as filter capacity, timer displays, alarm or error messages, as well as icons that illuminate when cabinet functions such as the light and blower are operational.

[BLOWER] – Starts or stops the cabinet blower. When the blower is in automatic (SmartStart) mode, opening the sash the closed position turns the blower on automatically. The cabinet can also be configured so that when the sash is closed, the motor slows to maintain air cleanliness in the work (NightSmart). When the sash is reopened, the blower resumes normal operation. Pressing the blower button at any overrides the automatic operation.

[LIGHT] – Turns the LED lamps on or off. Closing the sash automatically turns the lights off. When the lights are in automatic (SmartStart) mode, raising the sash turns the lights automatically. Pressing the light button at any time overrides automatic operation.

[OUTLETS] – Turns on/off electrical outlets in the work area.

[UV LIGHT] – Turns on/off the UV lamp (when installed). When the UV lamp is in automatic mode, closing the sash the UV light on automatically. When the sash is raised, the light turns off automatically.

[TIMER] – Allows you to select either a repeating interval or an elapsed timer (stopwatch).

[OK/MUTE] – Mutes all audible alarms for approximately 5 minutes, unless there is a system error alarm. When in any this button is used to select an option.

[MENU] – From the Home Screen, this button accesses the Menu. When in any menu screen, pressing this button returns the previous menu level.

[UP] and **[DOWN]** – Moves between selectable options or change numerical fields in menu screens.

Figure 7-3



Sash Operation

The counterbalanced, anti-racking sash mechanism requires only a few pounds of force to move the sash up or down. You can open or close the sash smoothly with one or two hands positioned on either handle.

The sash position alarm and safety interlock system senses the sash position and acts appropriately. The cabinet has been programmed to operate at either an 8-inch (203 mm) or 10-inch (254 mm) sash opening, depending on the model. Raising the sash above or below its operating height will activate the audible and visual alarms. The audible alarm can be temporarily muted for approximately five minutes by pressing the **[OK/MUTE]** button on the Keypad. Moving the sash back to its operating position will reset the alarm. The safety interlock system senses when the sash is closed and allows the optional UV lamp to operate only when the sash is closed, to protect the operator from irradiation.

Blower Operation

The Axiom Type C1 biosafety cabinet can be configured to automatically turn on the internal blowers. If this feature is enabled, raising the sash from closed to operating height will automatically turn on the blowers. If this feature is not enabled, raise the sash to operating height, and press **[BLOWER]**. Either method will start the blowers, and the *Blower Starting* screen will appear for approximately 1 minute.

If the product is configured to operate in B-mode, and the building's exhaust system is not pulling the required volume of exhaust air through the exhaust housing, you will first see *Exhaust Airflow Check* before *Blower Starting* appears. If the building exhaust system does not reach the required minimum volume of airflow within 1 minute, an alarm will occur.

Light Operation

The Axiom Type C1 biosafety cabinet provides dual LED lamps for illuminating the work surface. The cabinet can be configured to automatically turn on the LED lighting. If this feature is enabled, raising the sash from closed to operating height will automatically turn on the LED lighting. If this feature is not enabled, raise the sash to operating height, and press **[LIGHT]**. Either method will illuminate the LED lighting.

Outlet Operation

The Axiom Type C1 biosafety cabinet provides two GFIC outlets with a maximum total amperage draw of 5A (115v models) or 3A (230v models). Power to the outlets can be

activated or deactivated from the Keypad. To activate or deactivate power to the outlets, press **[OUTLET]**.

Vacu-Pass™ Cord & Cable Pass Thru (optional)

The Vacu-Pass allows for passage of a cord, cable, or tube from within the product. The pass thru provides a sealed plug, and the plug housing is maintained under negative pressure to safely pass cords through the right side wall of the product. Not all models are configured with a Vacu-Pass port, if your model does not contain this option, this section may be skipped.



Note: There must be enough clearance to pass the cord between the product's exterior side panel and any obstruction such as a wall or other device.



Some Vacu-Pass components and the cord passing through it may become contaminated during use of the cabinet. Ensure all potentially contaminated components are surface decontaminated before handling or removal from the cabinet.

1. Locate the Vacu-Pass pre-cut accessory plug supplied in the Parts Box (see [Section 4: Installation](#) for location of the Parts Box).
2. Remove the grommet from the liner side wall. Remove the solid plug from the body of the portal by either pressing it through from the outside, or by carefully inserting a spatula or similar device between the sealing plug and the body of the portal, and prying the plug out. Save the solid plug. Locate the pre-cut accessory plug.
3. Pass the cord or cable through the body of the portal, and then through one of the pre-cut accessory plug holes, then through the grommet, as shown in Figure 7-4.

Note: Select a pre-cut plug hole that is slightly smaller than the cord or cable, to create a proper seal. The pre-cut plug has a core piece that must be removed before inserting the cord.

Figure 7-4

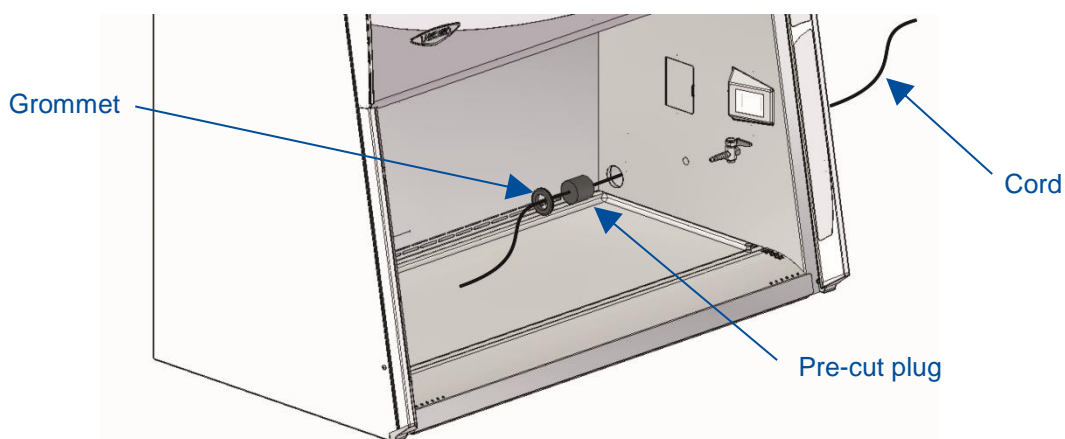

4. Position the cord or cable as it will be used in the cabinet, and then push the plug back into the body of the portal until it seats in the portal. Reinstall the grommet.

Working in the Cabinet

Working in the Axiom Type C1 biosafety cabinet requires preparation, planning, and an understanding of aseptic technique to work safely. The steps below represent the minimum requirements before, during, and after working in a biosafety cabinet. Consult your Health & Safety department for additional SOP requirements.

Planning

1. Thoroughly understand procedures and equipment required before beginning work.
2. Arrange for minimal disruptions, such as room traffic or entry into the room while the cabinet is in use.

Cabinet Start-up

1. Turn off UV light (if included on your cabinet).
2. Slowly raise the sash until the bottom of the sash aligns with the sash indicator decal located on the left side of the work area (See Figure 7-1).
3. Turn on the light and cabinet blower if the automatic features have not been enabled.
4. Check the air grilles for obstructions.
5. Allow the cabinet to operate until the Home Screen is shown.

Figure 7-5

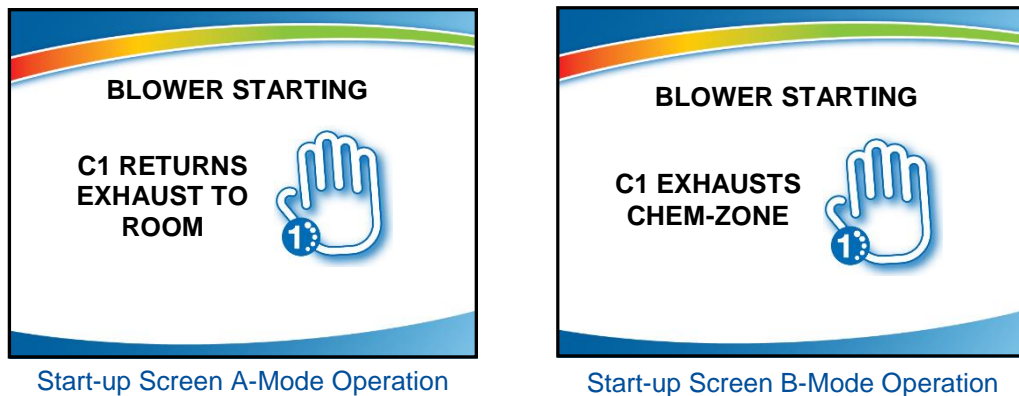

6. Wash hands and arms thoroughly with germicidal soap.
7. Wear appropriate personnel protective equipment (PPE).

Wipe Down

1. Raise the sash to its full open position. Mute the alarm by pressing **[OK/MUTE]**.
2. Wipe down the interior surfaces of the cabinet with 70% ethanol, or a suitable disinfectant, and allowed to dry.

Loading Materials and Equipment

1. Only load the materials required for the procedure. Do not overload the cabinet.
2. Do not obstruct the front, side, or rear return air grilles.
3. Large objects should not be placed close together.
4. Slowly close the sash until it is in the correct operating position.
5. After loading the cabinet, wait two to three minutes to purge airborne contaminants from the work area.

Work Techniques

- Keep all materials at least 4 inches (100 mm) inside from the sash, and perform all contaminated operations as far to the rear of the work area as possible.
- Segregate all clean and contaminated materials in the work area.
- Arrange items to minimize movement of contaminated materials into clean areas.
- Keep all discarded contaminated material to the rear of the work area.
- Avoid moving materials or the operator's hands and arms through the front access opening during use.
- Avoid the use of an open flame. Use disposable labware or an electric incinerator as alternatives.
- Use proper aseptic technique.
- Avoid techniques or procedures that disrupt the airflow patterns of the cabinet.
- If there is a spill or splatter during use, all objects in the cabinet should be surface decontaminated before removal. Thoroughly disinfect the working area of the cabinet WHILE IT IS STILL IN OPERATION, to prevent the release of contaminants from the cabinet.

Final Purging

- Upon completion of work, the cabinet should be allowed to operate for two to three minutes undisturbed, to purge airborne contaminants from the work area.

Unloading Materials and Equipment

- Objects in contact with contaminated material should be surface decontaminated before removal from the cabinet.
- All open trays or containers should be covered prior to removal from the cabinet.

Wipe Down

1. Wipe down the interior surfaces of the cabinet with a suitable disinfectant, or 70% ethanol, and allowed to dry.
2. Periodically lift the work surface and wipe down the area beneath it.
3. Inspect and clean the towel catch located at the rear of the work area, beneath the work surface.
4. Dispose of rubber gloves appropriately, and have lab coat laundered properly.
5. Wash hands and arms thoroughly with germicidal soap.

Shutdown

- Lower the sash and turn off the light and cabinet blower. Activate the UV light, if installed.

8: Maintaining Your Axiom Type C1

This section details normal maintenance required for optimal operation of the Axiom Type C1 biosafety cabinet. This section does not cover service operations beyond normal maintenance, nor does it cover annual airflow certification procedures. These advanced sections are found in the Axiom Type C1 Technical Manual.

Maintenance Safety Precautions

The following tools and supplies are required to maintain the equipment:



- #2 Phillips Screwdriver
- 70% alcohol solution (or other approved surface disinfectant)
- Paper Towels



The following safety precautions must be followed by all personnel maintaining the equipment.

- Wear safety glasses, and/or additional eye and face protection as required by your Health & Safety Department.
- Wear gloves, and/or additional skin protection as required by the safety instructions for the specific cleaning/disinfecting chemicals used. Consult your Health & Safety Department for additional skin protection requirements.
- No loose fitting clothes
- Wear close-toed shoes
- Although the service operations detailed in this section do not involve access to areas of the product with moving or electrical parts, should you remove any panels that expose moving or electrical parts, you must follow these instructions before doing so:
 - Disconnect main power cord or electrical service connection
 - Never touch moving parts such as fan blades or blower wheels.
- Never touch the HEPA (or ULPA) filter media. Touching the media will damage it, and result in a failure of the filter to function properly and maintain safe conditions.



Recommended Maintenance Schedule

Table 8-1

Activity	Maintenance Frequency		
	Weekly	Monthly	Annually
Disinfect interior surfaces (with suitable chemical disinfectant)	•	•	•
Wipe down interior surfaces after contact time elapsed with 70% alcohol solution	•	•	•
Clean sash glass and UV lamp with suitable glass cleaner	•	•	•
Operate cabinet blower, noting Filter Life percentage in log	•	•	•
Using 70% alcohol solution, wipe down cabinet exterior		•	•
Disinfect and lift work surface. Surface disinfect the area beneath with suitable chemical disinfectant		•	•
Wipe down area beneath work surface after contact time elapsed with 70% alcohol solution		•	•
Check all service valves (if equipped) for proper operation		•	•
Check the UV Lamp Hourmeter, noting in log		•	•
Have the cabinet recertified by a qualified technician			•

Service Operations

The operations in this section provide instructions to maintain the Axiom Type C1 for normal consumable replacement, and access to parts in accordance with the Recommended Maintenance Schedule. This section does not cover service operations beyond normal maintenance, nor does it cover annual airflow certification procedures. These advanced sections are found in the Axiom Type C1 Technical Manual.

Resetting a Circuit Breaker

Should an over current situation arise during normal operation, the circuit breakers located on the left side of the top electrical box will trip, protecting the cabinet from damage.

The Axiom Type C1 biosafety cabinet offers internal outlets to power small devices inside the cabinet. The internal outlets are protected by one circuit breaker (two circuit breakers on 230v models), and the cabinet electronics are protected by different circuit breaker (two different circuit breakers on 230v models). This allows the cabinet to continue to operate, providing protection to the product and user, should a device connected to an internal outlet experience an over current situation.

If the internal outlets do not have power when the Outlet icon is displayed on the Home Screen, reset the appropriate circuit breaker(s) as shown in Figure 8-1. The outlet circuit breaker(s) are in the Rear Position(s).

If the cabinet does not have power when the System Reset Switch (Figure 7-2) is on, reset the appropriate circuit breaker(s) as shown in Figure 8-1. The cabinet circuit breaker(s) are in the Front Position(s).

The thrown circuit breaker will be easy to identify, as the white barrel will be extended further than the other circuit breaker(s). To reset, simply push it in.

Figure 8-1

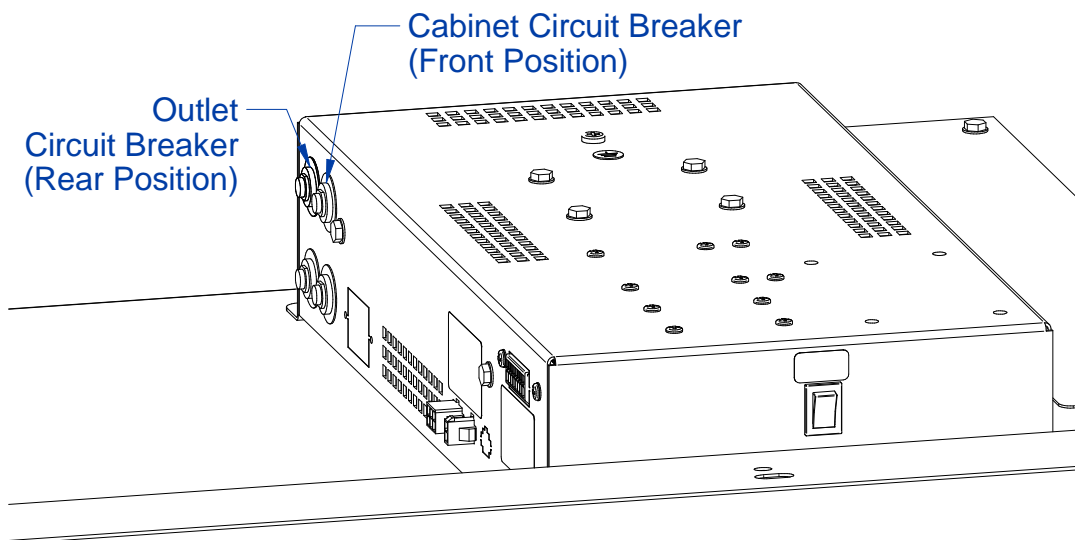

Center Work Surface Removal

To hinge the center work surface open, reference Figures 7-1 and 8-2 for part identification and follow these steps.

1. Turn the cabinet blower on.
2. Lift either wing work surface approximately 2 inches (50 mm) by grasping the knobs at either front corner.
3. This will lift the center work surface. Grasp the front edge of the center work surface, and lift the front edge vertically, pivoting the work surface on its back edge until the front edge of the work surface engages the latch on the back wall of the work area.



If removing the center work surface from the cabinet, the work surface must be thoroughly decontaminated before removing it from the cabinet.

To reinstall the center work surface, lift up on the latch on the back wall, and gently lower the work surface back into position. Take care to engage the pins in the front corners of the work surface with the holes in the grille.

Figure 8-2

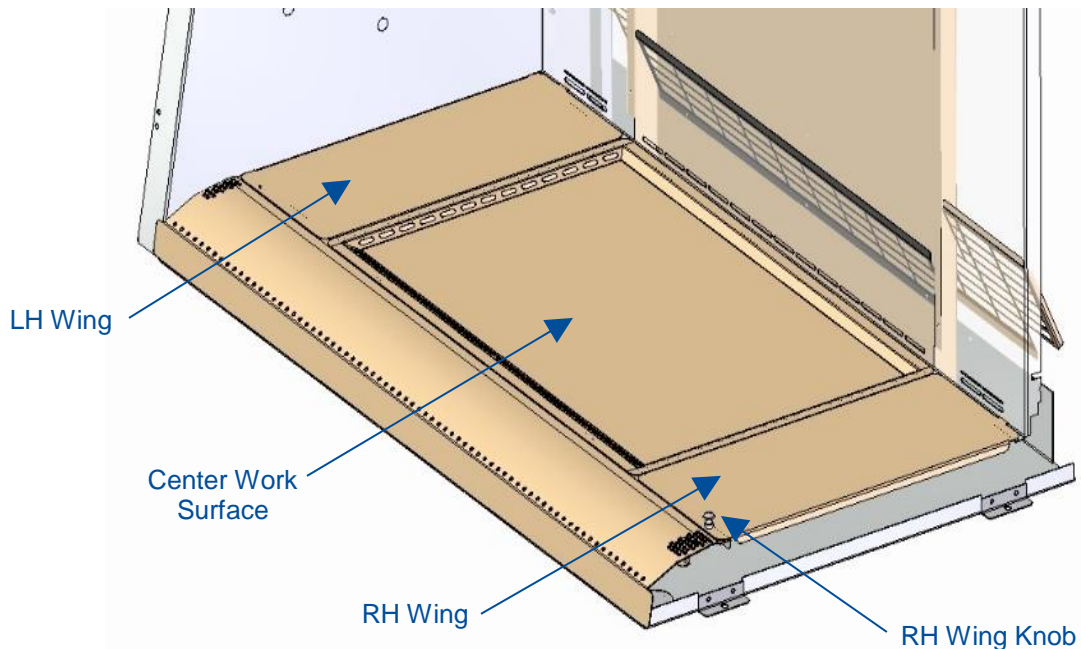

Wing Work Surface Removal

Before beginning, the center work surface must be hinged open or removed as described previously. Reference Figures 7-1 and 8-2 for part identification and follow these steps.

1. If not already on, turn the cabinet blower on.
2. Lift either wing work surface approximately 2 inches (50 mm) by grasping the knobs at either front corner.
3. Grasp the front edge of the wing work surface and pull it forward to free the locating tab at the rear edge from the back wall of the cabinet.



If removing either wing work surface from the cabinet, the wing work surface must be thoroughly decontaminated before removing it from the cabinet.

Once the wing work surfaces are removed, the center drip tray will remain, see Figure 8-3.

To reinstall the wing work surface, engage the locating tab on the rear edge with the slot in the back wall of the cabinet. Gently hinge the wing down. Take care to engage the pin in the front corner of the wing work surface with the hole in the grille.

Figure 8-3

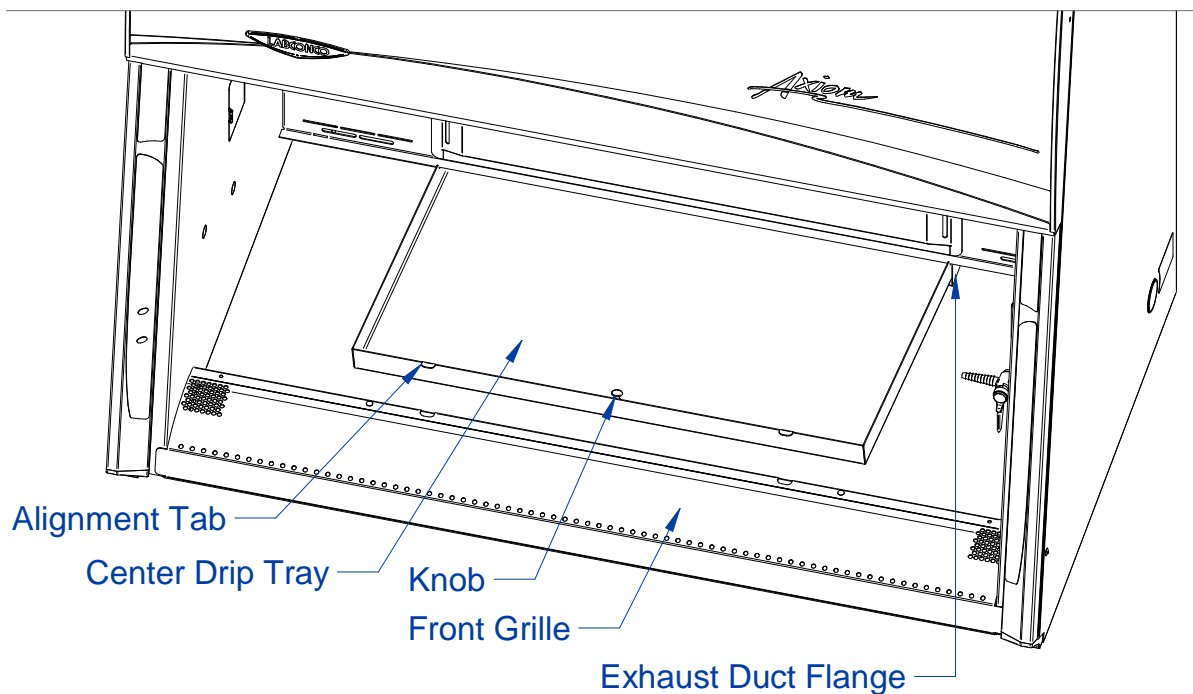

Center Drip Tray Removal

Before beginning, the center work surface must be hinged open or removed, and the wing work surfaces removed as described previously. Reference Figure 8-3 for parts identification.

1. If not already on, turn the cabinet blower on.
2. Grasp the knob located in the center of the center drip tray. Pull the knob up to hinge the center drip tray up about 2 inches (50 mm).
3. Grasp the front or side edges of the Center Drip Tray, and pull forward while continuing to rotate the front edge up.



If removing the center drip tray from the cabinet, the drip tray must be thoroughly decontaminated before removing it from the cabinet.

To reinstall the center drip tray, hold the front edge higher than the back edge, and gently set the back edge on the exhaust duct flange. Slide the center drip tray backwards while also hinging it down and into its final position. Take care to engage the two alignment tabs on the front edge of the center drip tray into the cutouts in the front grille.

Front Grille Removal

Before beginning, the center work surface must be hinged open or removed, the wing work surfaces removed, and the center drip tray removed as described previously. Reference Figure 8-3 for parts identification.

1. If not already on, turn the cabinet blower on.
2. Grasp the front grille with two hands, one on the inside edge and one on the outside edge. Pull the front grille up, while also rotating the top slightly inward.



Note: It may be difficult to raise the front grille at first. If so, move to one end of the front grille, and follow step #2 while also rotating the grille up on that end. Once one end has raised slightly, then move back to the middle and continue to lift it up.



If removing the front grille from the cabinet, the front grille must be thoroughly decontaminated before removing it from the cabinet.

Front Panel Removal

Removal of the front panel is only necessary to change the LED lamps.



Tools Required:

- #2 Phillips Screwdriver



It is recommended to utilize at least two (2) persons to remove the front panel, particularly for a 6-ft model. The front panel is heavy. Take care to use safe lifting practices, and to set the panel where it cannot fall over while uninstalled from the cabinet.

1. Locate and remove the two Phillips screws that secure the front panel as shown in Figure 8-4. They are located on the bottom corners of the front dress panel.
2. Swing the bottom of the dress panel out to clear the LED lamps and then lift the front dress panel straight up and away from the cabinet.

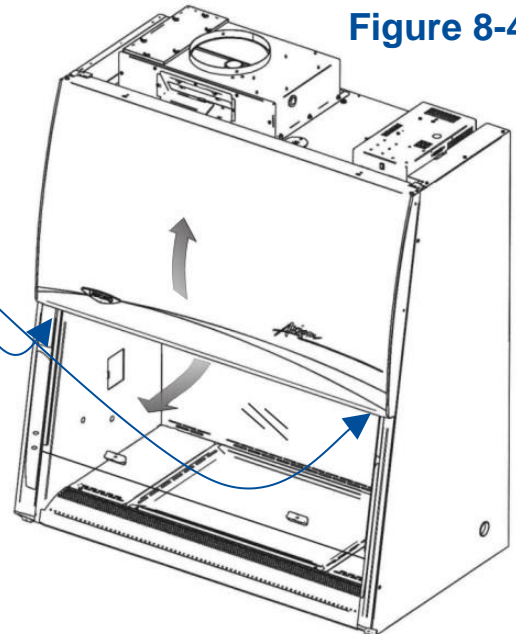

Figure 8-4



Before removing the dress panel, remove all electrical power to the cabinet by disconnecting the power cord from the cabinet.

To reinstall the panel, reverse these steps, ensuring that the plastic pins in the top corners of the front dress panel are properly engaged in the top of each corner post.

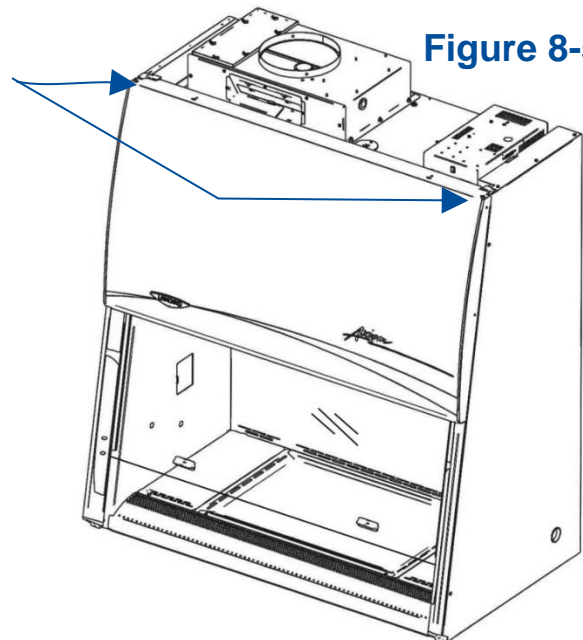

Figure 8-5

Changing the LED Lamps



Before proceeding, make sure all electrical power has been removed from the cabinet by disconnecting the main electrical connection, which is the power cord.



This product uses only LED direct drive lighting. Do NOT install fluorescent bulbs.

1. Remove the dress panel as noted in Figure 8-4.
2. Locate the Left End Cap that aligns both LED lamps (Figure 8-6), remove the Left End Cap by pulling it away from the lamp ends.

Figure 8-6

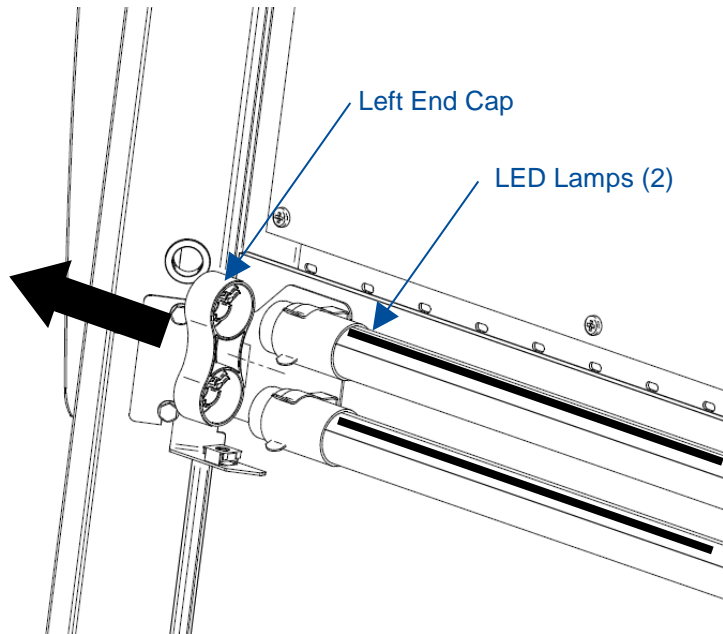

3. Remove both Socket Caps (on the right end of each LED lamp) by pulling each Socket Cap straight off the right end of the lamp one at a time (Figure 8-7).

Figure 8-7

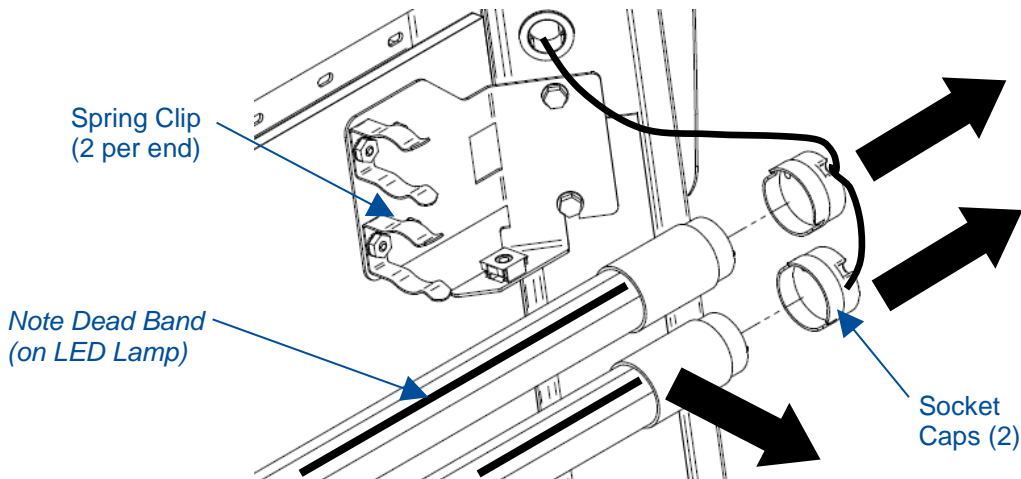

4. Pull each LED Lamp straight toward you to release the lamp from the two Spring Clips holding it in place (Figure 8-7). Note the rotational position of the old LED lamps (there is a dead band stripe that will need to be oriented the same when reinstalling the new LED Lamps).
5. Install the new LED Lamps by reversing the removal procedure. Take care to look at both ends of the new LED Lamps. One end is labeled with a '+' & '-' and 'L' & 'N' (Figure 8-8). This end of the new LED Lamp must go to the right, and is inserted into the Socket Cap.

Figure 8-8

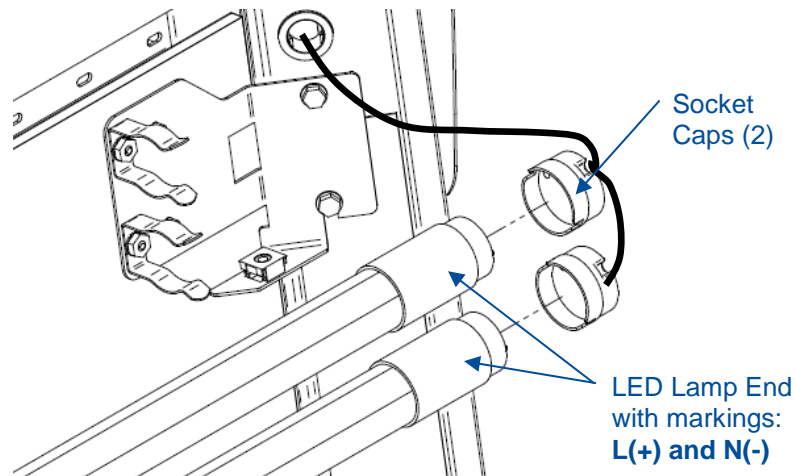

6. When reinstalling the Left End Cap, the pins on each LED Lamp must align rotationally with the Left End Cap. This ensures the dead band stripe is positioned correctly for maximum cabinet lighting.

Changing the Optional UV Lamp

The UV Lamp is an optional feature and may not be found on all models.



THE UV LAMP IN THIS PRODUCT CONTAINS MERCURY

Manage in accordance with local disposal laws. DO NOT place lamps in trash. Dispose as a hazardous waste. For information regarding safe handling, recycling and disposal, consult www.lamprecycle.org

CETTE LAMPE (UV) DANS CE PRODUIT CONTIENT DU MERCURE

Éliminez ou recyclez conformément aux lois applicables. Pour de l'information concernant des pratiques de manipulation sécuritaires et l'élimination sécuritaire et le recyclage, veuillez consulter www.lamprecycle.org



For optimum performance, the UV lamp should be changed as indicated by the UV lamp hourmeter.



The UV lamp and the work area of the cabinet must be thoroughly decontaminated before removing the lamp.

1. Start the cabinet blower and let it operate for 5 minutes.
2. Raise the sash to its full open position.
3. Thoroughly surface decontaminate the UV lamp and the work area of the cabinet.
4. Unplug the cabinet or turn off the System Reset Switch, located on the top of the cabinet.
5. Remove the UV lamp by rotating it 90 degrees and lifting it straight up and out of its sockets.
6. Install new lamp by reversing the removal procedure.

Storage

If the cabinet is to be left unused for more than one month, it should be prepared for storage. Follow the instructions below.



The cabinet should not be stored in areas of excess humidity or temperature extremes. If the cabinet is moved during storage, it must be recertified before use.

1. Close the sash completely and seal the bottom edge with plastic sheeting.
2. Seal the exhaust outlet with plastic sheeting.
3. Unplug the cabinet.
4. Ensure that the cabinet will not be moved or disturbed while being stored.

9: Accessories

This section details the available field-installable accessories and approved modifications for your Axiom Type C1 biosafety cabinet.

Telescoping Base Stands

These stands are included with some product models, or available separately. The base stand catalog numbers are listed in Table 9-1 below. An optional caster wheel kit is available (catalog number 3730500).

Table 9-1

Cabinet Width (Feet)	Base Stand
4'	3401004
6'	3401006

Manual or Electric Hydraulic Lift Base Stands

These base stands offer infinitely adjustable height between 25.5 and 33.5 inches (648 – 851 mm), providing a cabinet work surface height of 28.0 to 36.0 inches (711 – 914 mm). The height is adjusted either by a manual (hand crank) or electric pump that drives the hydraulic legs of the stand. The hydraulic stands are equipped with fixed levelling feet. The base stand catalog numbers are listed in Table 9-2 below. An optional caster wheel kit is available (catalog number 3784000).

Table 9-2

Cabinet Width (Feet)	Manual Stand	Electric (115v)	Electric (230v)
4'	3780201	3780101	3780104
6'	3780202	3780102	3780105



Note – Make certain service and exhaust connections to the product are properly prepared to allow for the raising or lowering of the product with these stands.

SoLo™ Electric Hydraulic Lift Base Stands

These base stands permit the cabinet to be lowered enough to transport it through a standard doorway as low as 84 inches (2133 mm). They offer infinitely adjustable height up to 33.5 inches (851 mm), providing a cabinet work surface height up to 36.0 inches (914 mm). The hydraulic stands are equipped with locking casters. The base stand catalog numbers are listed in Table 9-3 below.

Table 9-3

Cabinet Width (Feet)	SoLo (115v)	SoLo (230v)			
	North America	North America	UK	Europe (Schuko)	China / Australia
4'	3780311	3780315	3780331	3780335	3780339
6'	3780313	3780317	3780333	3780337	3780341



Note – Make certain service and exhaust connections to the product are properly prepared to allow for the raising or lowering of the product with these stands.

IV Bar

The IV Bar can be field installed on any size Axiom biosafety cabinet. The bar allows for easy hanging of IV bags used inside the biosafety cabinet. Catalog numbers are listed in Table 9-4 below.

Table 9-4

Cabinet Width (Feet)	Catalog Number
4'	3858601
6'	3858603

Flat Work Surface

Some users may wish to exchange the dished Chem-Zone work surface of an Axiom with a flat replacement work surface. Catalog numbers are listed in Table 9-5 below.

Note: Axiom BSCs used with flat work surfaces are not listed to NSF/ANSI Standard 49.

Table 9-5

Cabinet Width (Feet)	Catalog Number
4'	3458401
6'	3458403

Airflow Sensor

The Airflow Sensor can be field installed on any size Axiom biosafety cabinet. The sensor monitors the average inflow air velocity at the front work opening of the biosafety cabinet, and provides the inflow velocity on the display, as shown in Figure 9-1. The catalog number is listed in Table 9-6.

Figure 9-1



Inflow Display

Table 9-6

Cabinet Width (Feet)	Catalog Number
All	3405500

Bag In Bag Out Exhaust HEPA Filter

The Axiom can be factory-fitted with a Bag In Bag Out (BIBO) exhaust HEPA filter. This allows for the exhaust HEPA filter to be replaced when it contains toxic or harmful particulate that cannot be decontaminated by gaseous sterilization.

Table 9-7

Cabinet Width (Feet)	Operating Sash Height	Knock Down Base Stand	Catalog Number*
4'	8 inches	No	30448x2xx
4'	8 inches	Yes	30448x3xx
4'	10 inches	No	30441x2xx
4'	10 inches	Yes	30441x3xx
6'	8 inches	No	30468x2xx
6'	8 inches	Yes	30468x3xx
6'	10 inches	No	30461x2xx
6'	10 inches	Yes	30461x2xx

*Catalog Number indicates an Axiom with BIBO factory-installed.
This feature is not available for field installation

Sash Prop

The sash prop magnetically fits into the sash track to ensure the sash remains open at the appropriate height for room balancing requirements. The catalog number is listed in Table 9-8.

Table 9-8

Sash Height (in)	Catalog Number
8	3620301
10	3620302
12	3620303

10: Troubleshooting

This section details common troubleshooting for your biosafety cabinet.

Blower and Lights not working

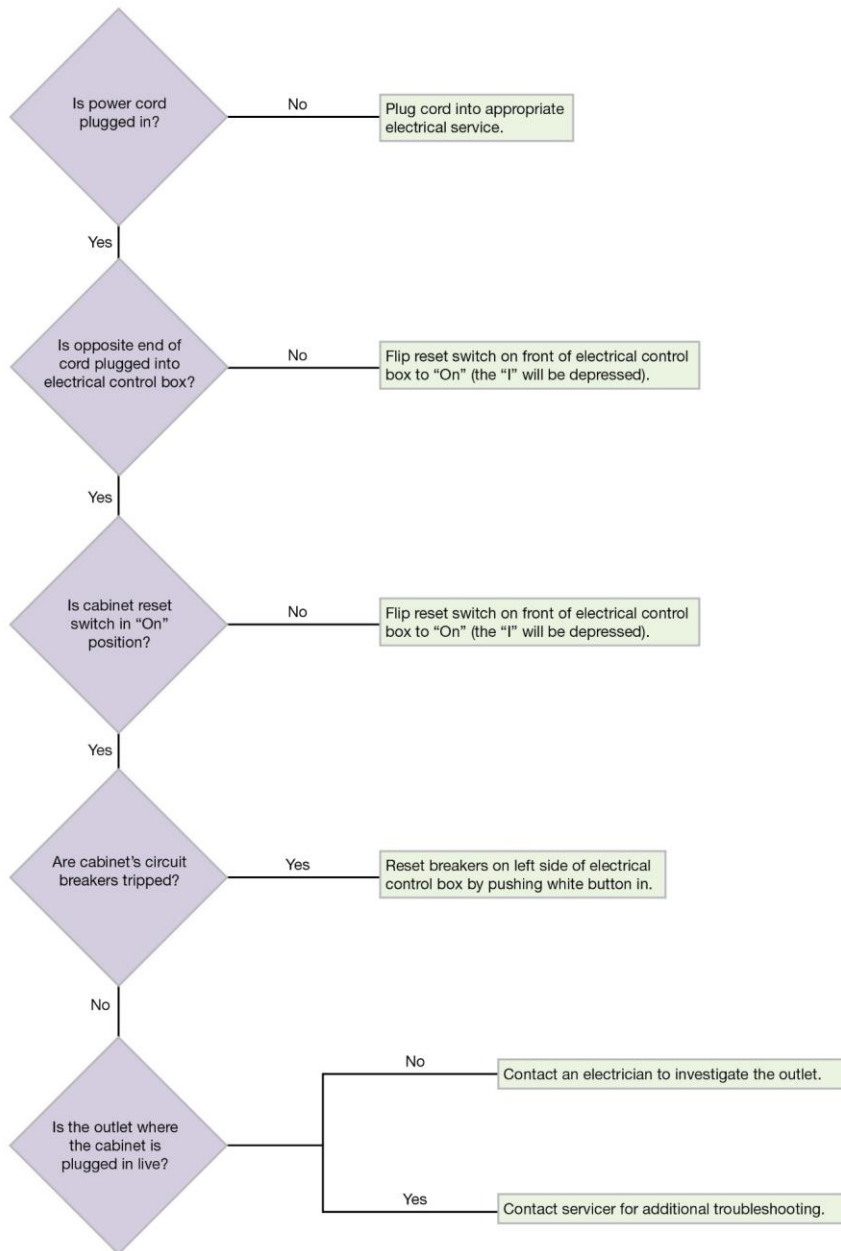

Blower only will not start

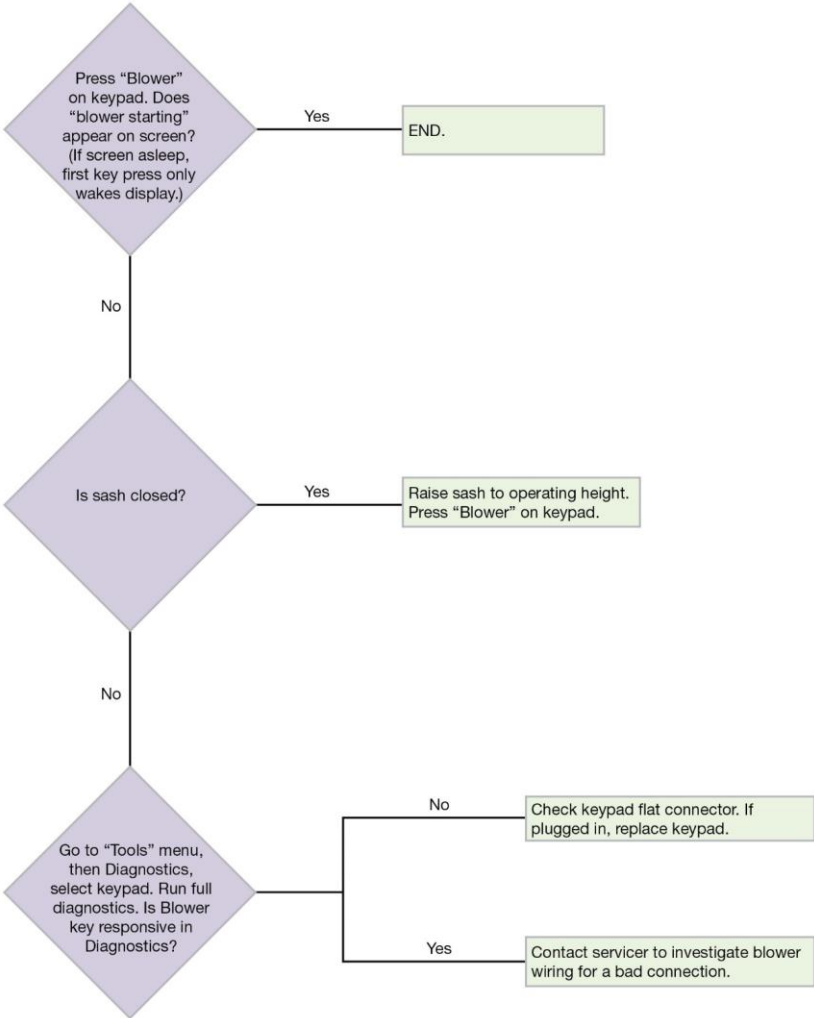

Lights only will not illuminate

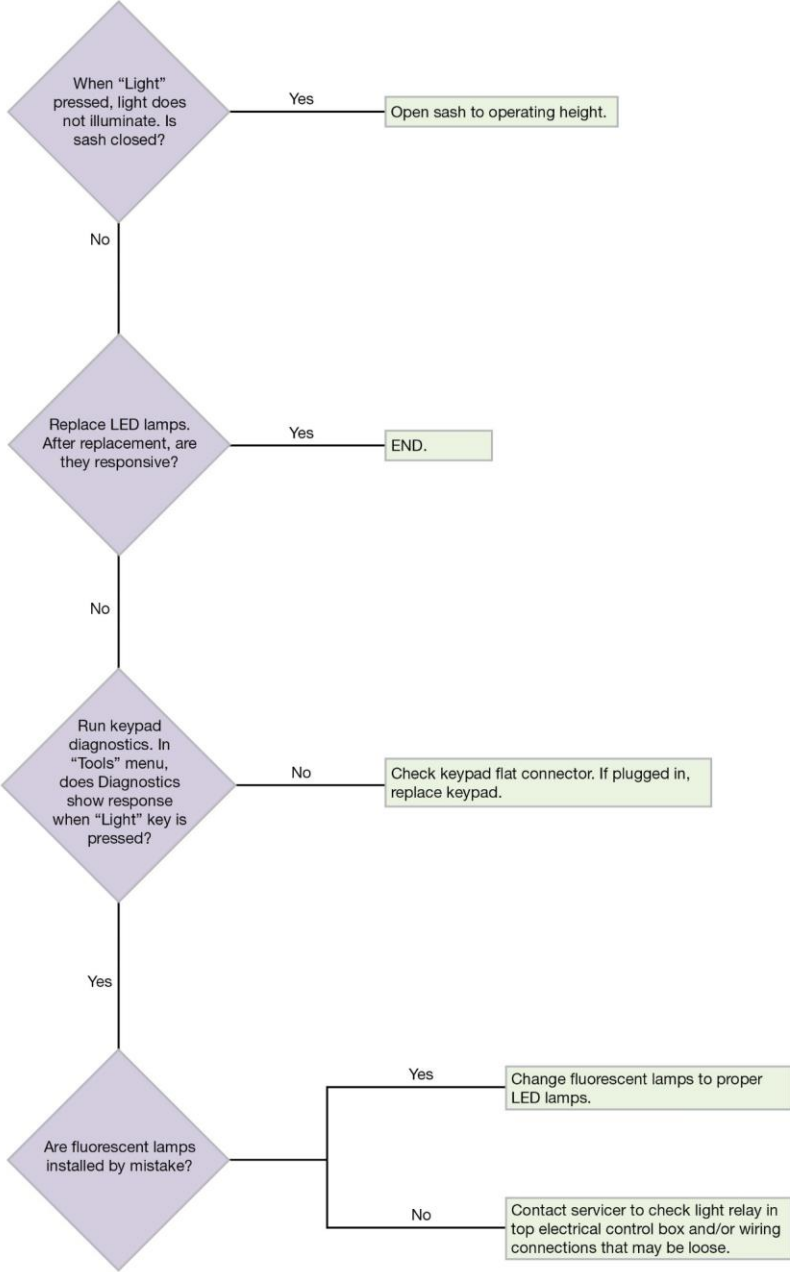

UV Light will not illuminate

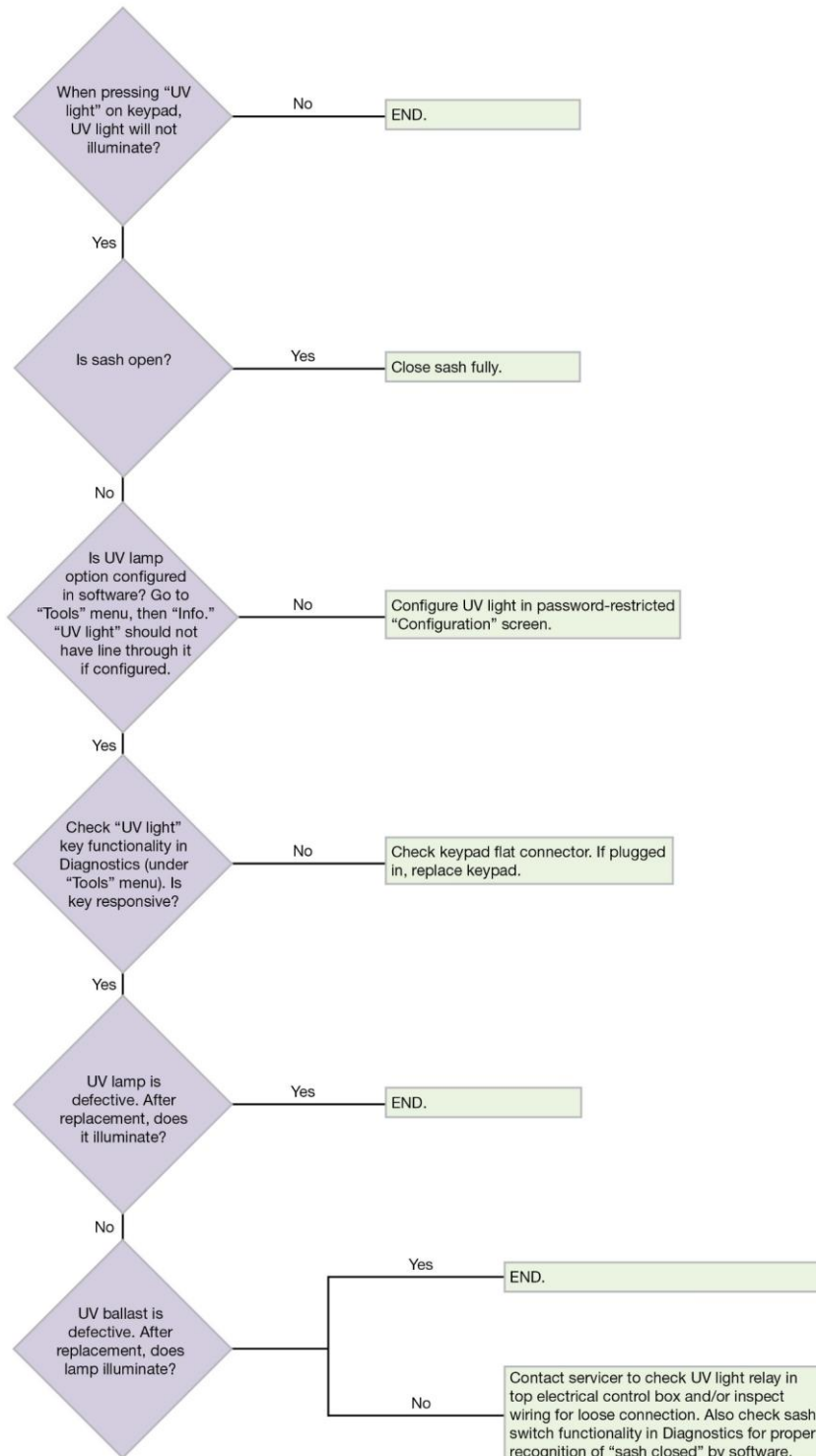

Airflow Alert activating

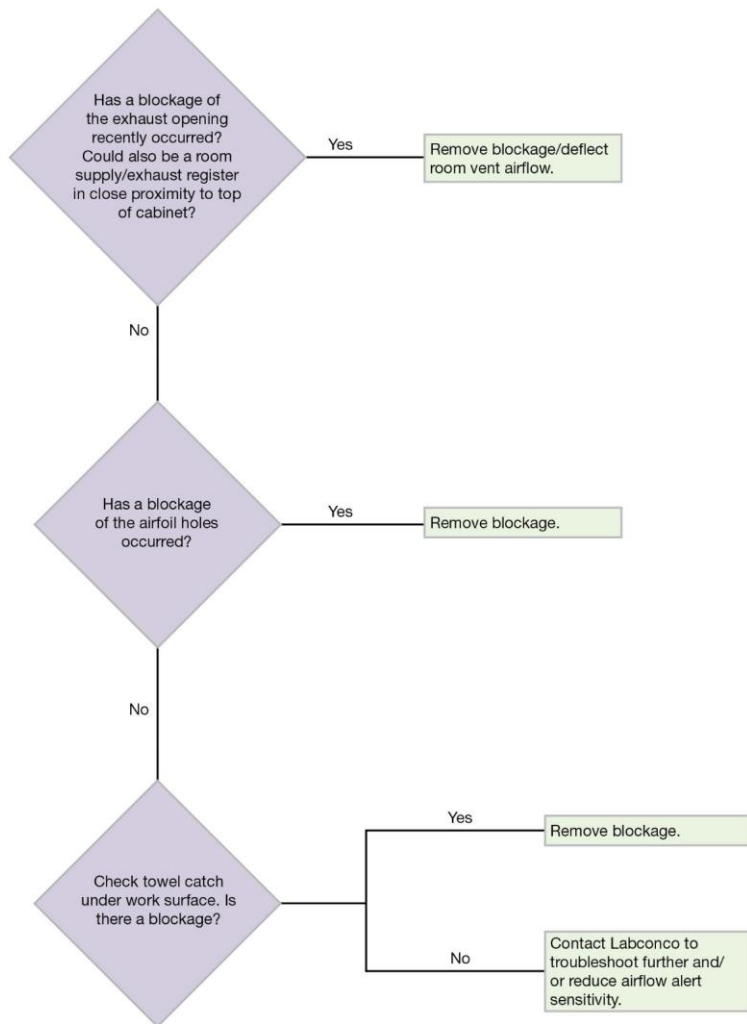

Filter Life Gauge not at 100% when new

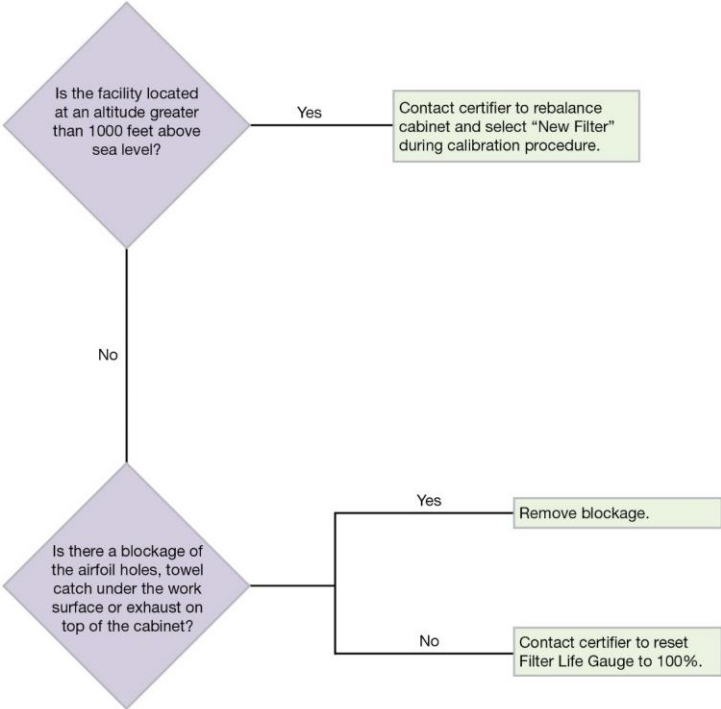

Contamination in the work area

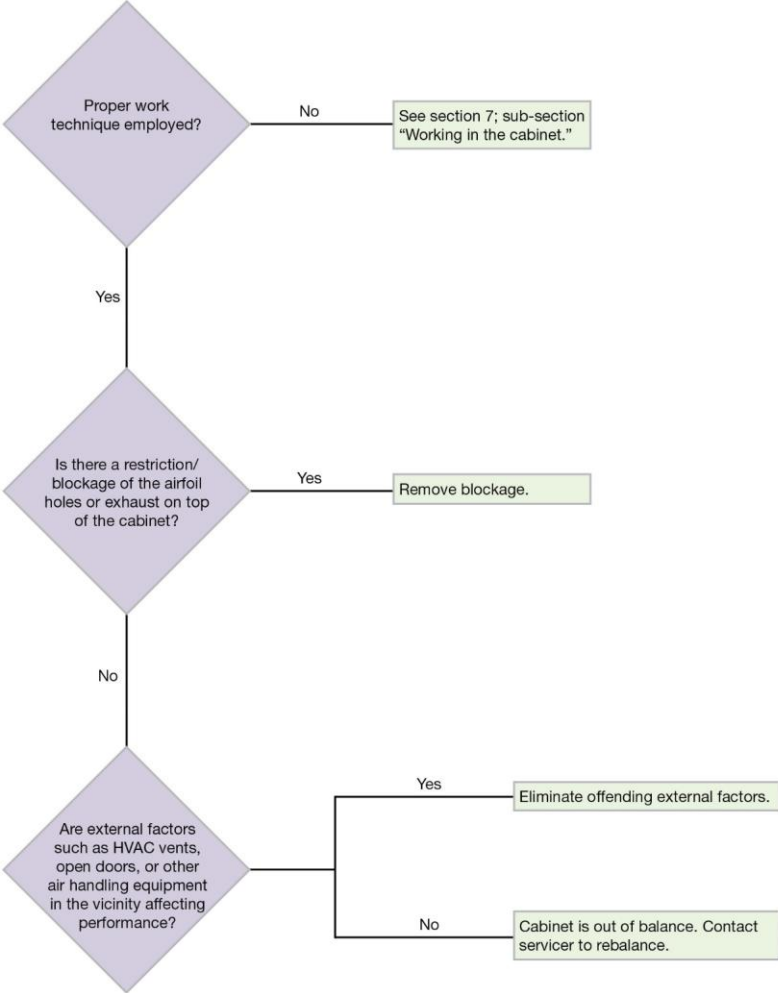

Appendix A: Parts List

Table A-1 and Figure A-1 indicate the location and catalog numbers for the following service, and replacement accessory components.

Table A-1

Item	Quantity Required	Catalog Number	Description
1	1	3838501	Exhaust HEPA Filter 4 Foot Model
	1	3838503	Exhaust HEPA Filter 6 Foot Model
2	1	3838401	Supply HEPA Filter 4 Foot Model
	1	3838403	Supply HEPA Filter 6 Foot Model
3	2	1297504	Lamp, LED, 4 Foot Model
	2	1297506	Lamp, LED, 6 Foot Model
4	1	1271300	Lamp, UV (models with UV light only)



This product uses only LED direct drive lighting. Do NOT install fluorescent bulbs.

Figure A-1

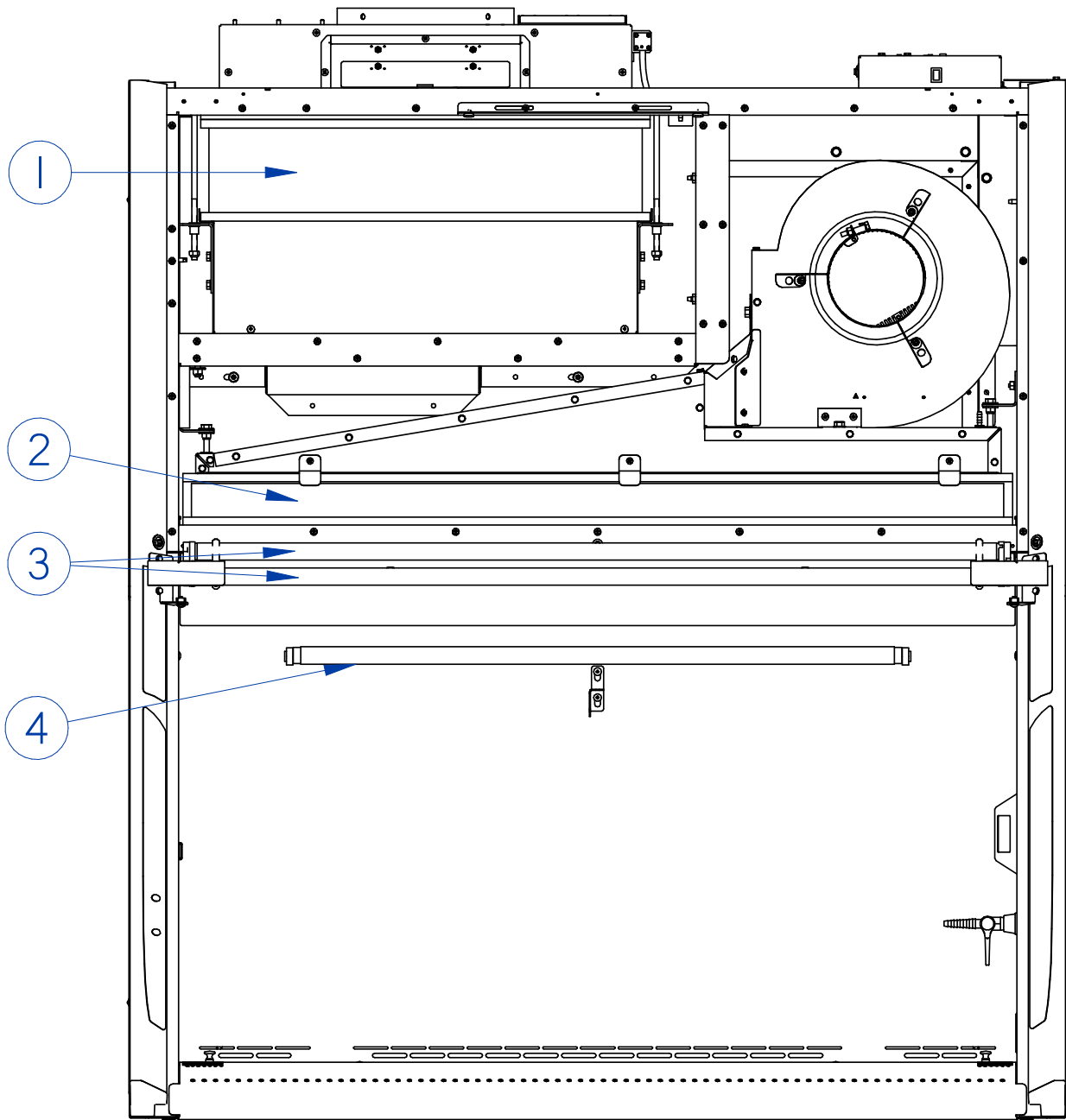

Appendix B: Dimensions

Table B-1 and Figure B-1 indicate the product dimensions. All dimensions shown in inches (centimeters).

Table B-1

Width	A	B	C*	D	E
4'	48.5 (123.2)	54.3 (137.9)	22.5 (57.2)	8.0 (20.3)	17.1 (43.4)
				10.0 (25.4)	
6'	72.5 (184.2)	78.3 (198.9)	22.5 (57.2)	8.0 (20.3)	28.2 (71.5)
				10.0 (25.4)	

*Bag In Bag Out Exhaust Filter Models C = 13.6 (34.5)

Figure B-1

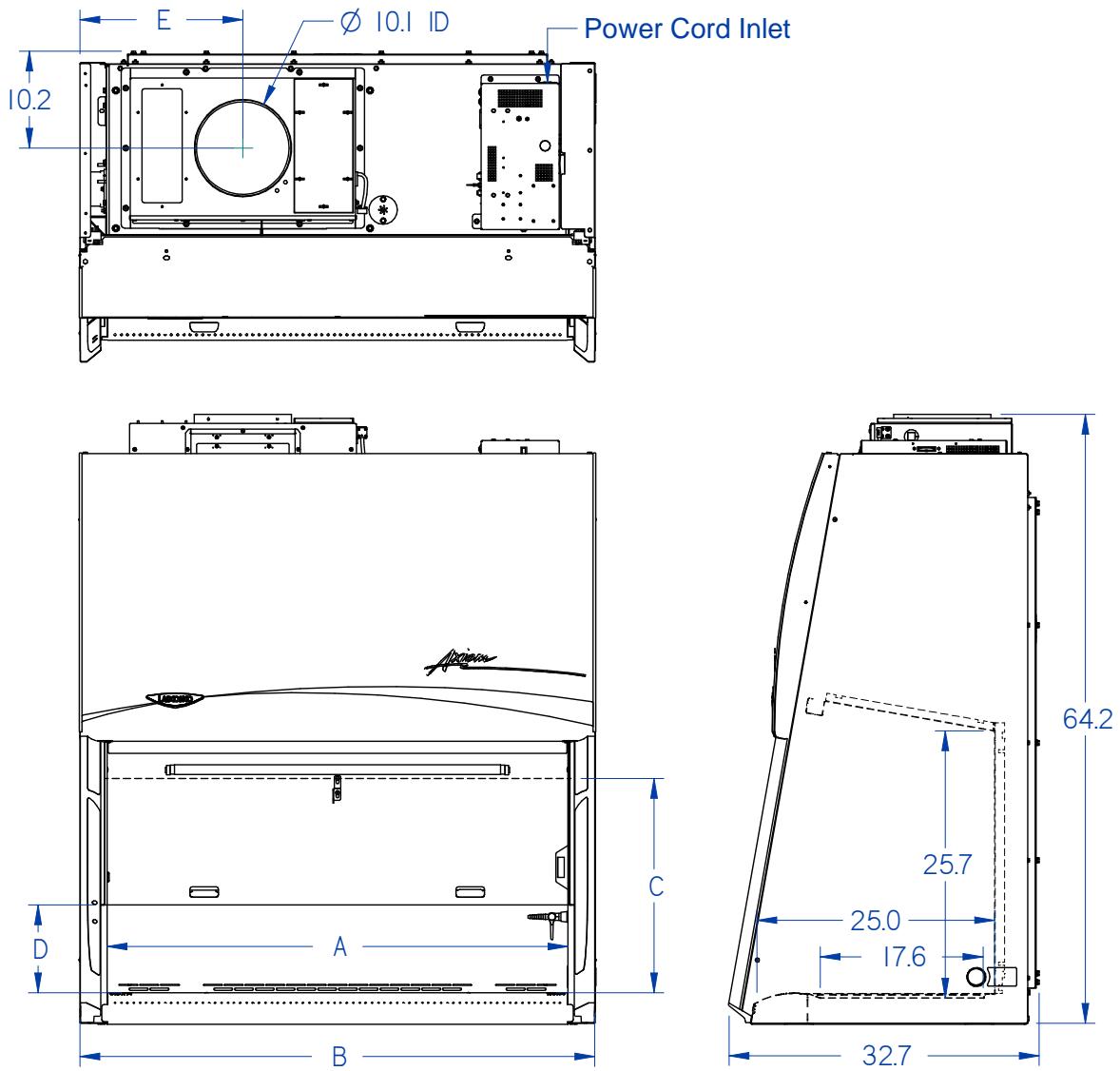

Appendix C: Specifications

Power Data

Table C-1

Catalog Number	Normal Operating Power (Watts) ¹
30448xxx1	340 W
30441xxx1	360 W
30468xxx1	440 W
30461xxx1	480 W

¹ Values are for new product with clean filters, and may vary +/- 10%

Motor Specifications

Table C-2

Product Size	Electrical Requirements
All Cabinets, all Voltages	1/3 H.P. Electronically Commutated Motor (ECM) 120-277 VAC – 50/60 Hz, Full Torque – 28 Oz.-Ft (2.37 N-M) 5.0 Full Load Amps @115VAC 2.8 Full Load Amps @230VAC Automatic Thermal Protection

Environmental Conditions

- Indoor use only
- Ambient temperature range: 41° to 104°F (5° to 40°C)
- Maximum relative humidity: 80% for temperatures up to 88°F (31°C), decreasing linearly to 50% relative humidity at 104°F (40°C)
- Main supply voltage fluctuations not to exceed $\pm 10\%$ of the nominal voltage
- Transient overvoltages according to Installation Categories II (Overvoltage Categories per IEC 1010). Temporary voltage spikes on the AC input line that may be as high as 1500V for 115V models and 2500V for 230V models are allowed
- Used in an environment of Pollution degrees 2 (i.e., where normally only non-conductive atmospheres are present). Occasionally, however, a temporary conductivity caused by condensation must be expected, in accordance with IEC 664

Appendix D: Quick Chart Reference

Table D-1

Model	30441	30448	30461	30468
Type	C1	C1	C1	C1
Cabinet Size (Feet)	4'	4'	6'	6'
Sash Opening (Inches)	10	8	10	8
Starting Serial Number ¹	2006	2006	2006	2006
Nominal Avg. Downflow (FPM)	65+/-5	65+/-5	55+/-5	55+/-5
Nominal Average Inflow (FPM)	105+/-5	105+/-5	105+/-5	105+/-5
Supply HEPA Data				
Labconco Catalog Number	3838401	3838401	3838403	3838403
Exhaust HEPA Data				
Labconco Catalog Number	3838501	3838501	3838503	3838503
Motor/Blower Data (2 ea)²				
Motor HP	1/3	1/3	1/3	1/3
LED Lamp/UV Lamp Data				
LED Lamps (2 each) ³	KT-LED 15T8-48GC- 840-D	KT-LED 15T8-48GC- 840-D	KT-LED 32T8-72GC- 840-D	KT-LED 32T8-72GC- 840-D
Color (°K)	4000	4000	4000	4000
Lumens	1850	1850	3200	3200
Glass Type	Frosted	Frosted	Frosted	Frosted
UV Lamp	G30T8	G30T8	G30T8	G30T8

1. The primary serial tag is on the lower right edge of the front dress panel. The secondary serial tag is located on the front of the electronics module on the top right side of the cabinet. The first two digits of the serial number are the year of production; the next two are the month. The next 5 digits are the sequence of production, and the letter following the serial number is the revision level of the cabinet.
2. Each motor must be programmed by Labconco for the appropriate width cabinet.
3. THIS PRODUCT USES DIRECT DRIVE T8 LED LAMPS INSTEAD OF FLUORESCENT LAMPS. THERE IS NO BALLAST; LINE VOLTAGE IS SUPPLIED TO THE LAMP SOCKETS.



This product uses only LED direct drive lighting. Do NOT install fluorescent bulbs.